



LTCC SURFACE MOUNT

# High Pass Filter

## HFCU-1382+

50Ω

14.3 to 29 GHz

### THE BIG DEAL

- Insertion Loss, Typ. 2.4 dB
- Good Rejection, Typ. 53 dB
- Good Return Loss, Typ. 14 dB
- 1812 Surface Mount Footprint
- Power Handling: 7 Watts

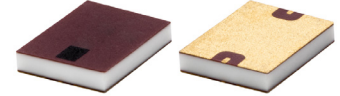

Generic photo used for illustration purposes only

### APPLICATIONS

- Test & Measurement Equipment
- Radar, EW, and ECM Defense System
- 5G MIMO and Back Haul Radio

### FUNCTIONAL DIAGRAM

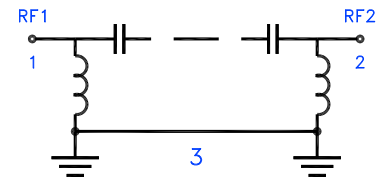

### PRODUCT OVERVIEW

Mini-Circuits' HFCU-1382+ is a miniature low temperature co-fired ceramic (LTCC) high pass filter with a 14.3 to 29 GHz passband supporting a variety of applications. This model provides 2.4 dB typical insertion loss over a wide band due to its rugged monolithic construction. Housed in an 1812 ceramic form factor which is ideal for dense signal chain PCB layouts where it complements MMIC size and performance. The LTCC fabrication process assures minimal RF performance variation while delivering a product that is well suited for environmental extremes of high humidity and temperature.

### KEY FEATURES

Features	Advantages
Wide Passband, 14.7 GHz	This filter has a very wide passband from 14.3 to 29 GHz.
LTCC Construction	Provides repeatable performance in a rugged, ceramic package well suited for tough environments such as high humidity and temperature extremes.
Small Size, 1812	Saves space in dense circuit board layouts and minimizes the effects of parasitics.
Rugged Power Handling, 7 Watts	Handles up to 7 Watts in a small 1812 package.



### ELECTRICAL SPECIFICATIONS<sup>1,2,3</sup> AT +25°C

Parameter		F#	Frequency (GHz)	Min.	Typ.	Max.	Units
Pass Band	Insertion Loss	F3-F4	14.3 - 17	—	2.3	—	dB
		F4-F5	17 - 26	—	2.4	3.1	
		F5-F6	26 - 29	—	3.0	—	
	Return Loss	F3-F4	14.3 - 17	—	12	—	dB
		F4-F5	17 - 26	—	14	—	
		F5-F6	26 - 29	—	11	—	
Stop Band	Rejection	DC-F1	DC - 8	43	53	—	dB
		F1-F2	8 - 10.8	20	32	—	
	Freq. Cut-Off <sup>4</sup>	Fc	13.5	—	3.0	—	dB

1. Tested in Evaluation Board P/N TB-HFCU-1382+.

2. Bi-directional, RF1 and RF2 can be interchanged.

3. This component should not be used as a DC-block. In applications where DC voltage and/or current is present at either the input or output ports, external DC blocking capacitors are required.

4. Typical variation ± 5%.

### ABSOLUTE MAXIMUM RATINGS<sup>5</sup>

Parameter	Ratings
Operating Temperature	-55°C to +125°C
Storage Temperature	-55°C to +125°C
Input Power <sup>6</sup>	7 W @ +25°C

5. Permanent damage may occur if any of these limits are exceeded.

6. Power rating applies only to signals within the passband. Power rating above +25°C operating temperature decreases linearly to 1.3 W at +125°C.

### TYPICAL FREQUENCY RESPONSE AT +25°C

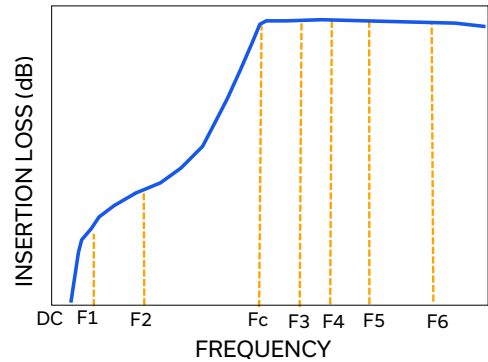



LTCC SURFACE MOUNT

# High Pass Filter

## HFCU-1382+

Mini-Circuits

50Ω

14.3 to 29 GHz

### TYPICAL PERFORMANCE GRAPHS

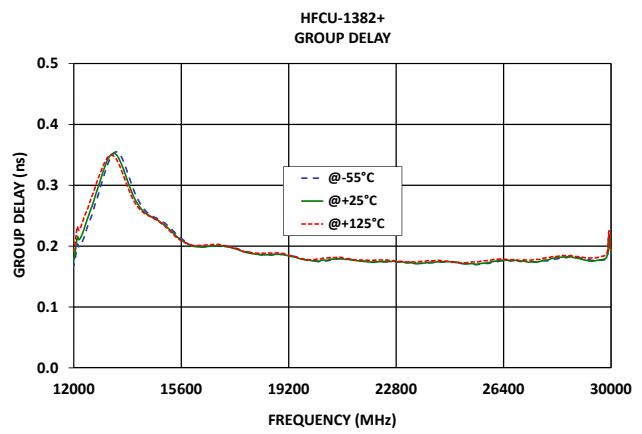
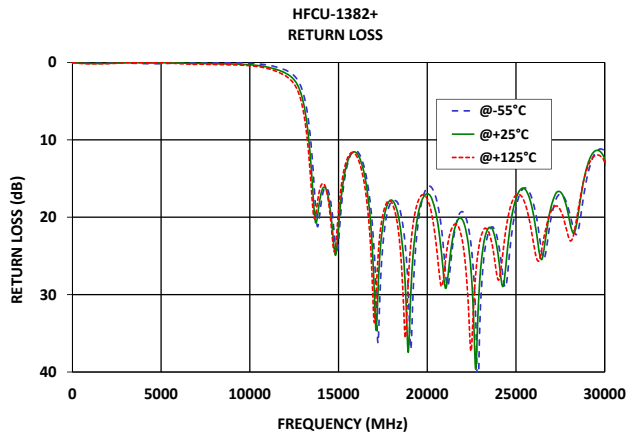
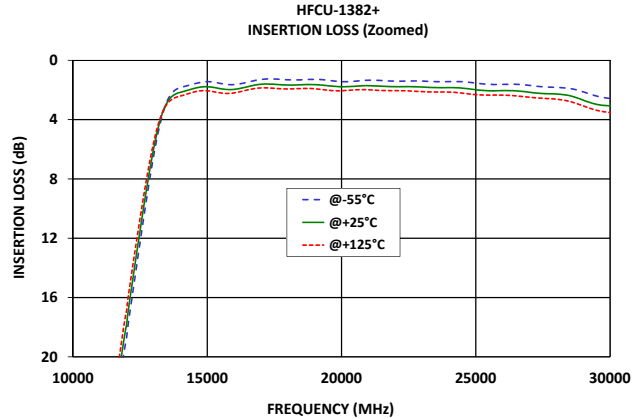
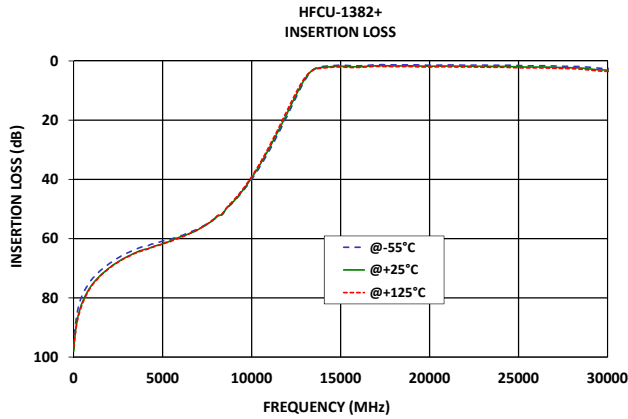



### FUNCTIONAL DIAGRAM

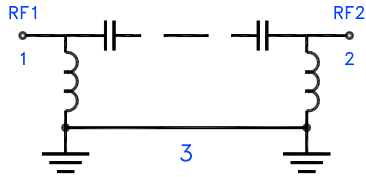
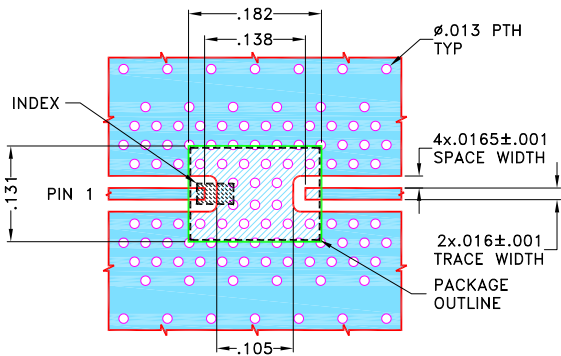

Figure 1. HFCU-1382+ Functional Diagram

### PAD DESCRIPTION

Function	Pad Number	Description
RF1 <sup>2</sup>	1	Connects to RF Input Port
RF2 <sup>2</sup>	2	Connects to RF Output Port
GROUND	3	Connects to Ground on PCB, (See drawing PL-708)

### SUGGESTED PCB LAYOUT (PL-708)



NOTES:

1. COPLANAR WAVEGUIDE PARAMETERS ARE SHOWN FOR ROGERS (RO4835 Lo Pro) WITH DIELECTRIC THICKNESS .0073±.0007; COPPER: 1/2 Oz. EACH SIDE. FOR OTHER MATERIALS TRACE WIDTH AND GAP MAY NEED TO BE MODIFIED.
  2. BOTTOM SIDE OF THE PCB IS CONTINUOUS GROUND PLANE.
- DENOTES PCB COPPER PATTERN WITH SMOBC (SOLDER MASK OVER BARE COPPER)  
 ▨ DENOTES PCB COPPER PATTERN FREE OF SOLDERMASK

Figure 2. PL-708 Suggested PCB Layout

### CASE STYLE DRAWING

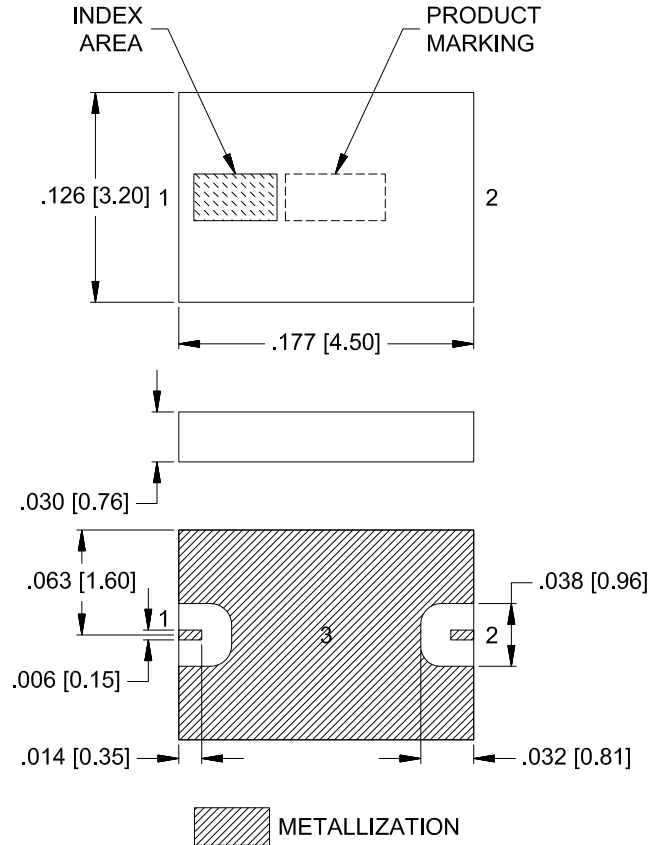

Weight: .04 grams

Dimensions are in inches [mm]. Tolerances: 2PI. ± .01; 3PI. ± .005

### PRODUCT MARKING\*: F518

\*Marking may contain other features or characters for internal lot control.



LTCC SURFACE MOUNT

# High Pass Filter

## HFCU-1382+

50Ω

14.3 to 29 GHz

ADDITIONAL DETAILED INFORMATION IS AVAILABLE ON OUR DASHBOARD.

[CLICK HERE](#)

Performance Data and Graphs	Data
	Graphs
	S-Parameter (S2P Files) Data Set (.zip file) De-embedded to device pads
Case Style	NM1812C-5 Lead Finish:Electroless Gold over Nickel Plating
RoHs Status	Compliant
Tape and Reel	F77
Suggested Layout for PCB Design	PL-708
Evaluation Board	TB-HFCU-1382+
	Gerber File
Environmental Rating	ENV06T10

### NOTES

- A. Performance and quality attributes and conditions not expressly stated in this specification document are intended to be excluded and do not form a part of this specification document.
- B. Electrical specifications and performance data contained in this specification document are based on Mini-Circuits' applicable established test performance criteria and measurement instructions.
- C. The parts covered by this specification document are subject to Mini-Circuits' standard limited warranty and terms and conditions (collectively, "Standard Terms"); Purchasers of this part are entitled to the rights and benefits contained therein. For a full statement of the standard terms and the exclusive rights and remedies thereunder, please visit Mini-Circuits' website at [www.minicircuits.com/terms/viewterm.html](http://www.minicircuits.com/terms/viewterm.html)

