



MMIC SURFACE MOUNT

Monolithic Amplifier

LEE1-63+

50Ω DC to 6000 MHz

THE BIG DEAL

- High Gain, Typ. 19.5dB
- High OIP3, Typ. +30 dBm
- High P1dB, Typ. +16.6 dBm
- Single Supply Voltage, 69 mA at +5 V
- 1.5x1.5 mm 6-Lead QFN-Style Package

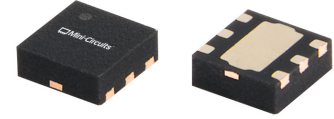

Generic photo used for illustration purposes only

APPLICATIONS

- Satellite Communications
- 5G MIMO and Backhaul MW Radio Systems
- Radar, EW and ECM Defense Systems

FUNCTIONAL DIAGRAM (TOP VIEW)

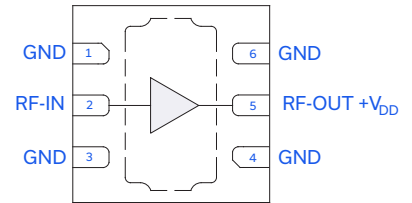

PRODUCT OVERVIEW

The LEE1-63+ is high-linearity gain block amplifier in a low-cost surface mount package fabricated using an InGaP/GaAs HBT semiconductor process. Operating from DC to 6000 MHz, this amplifier features high dynamic range with typical 3.4 dB noise figure, 19.5 dB gain, +16.6 dBm P1dB, and +30 dBm OIP3 at 3 GHz. This combination of performance makes it ideal for sensitive, high dynamic range receiver applications. The LEE1-63+ operates on a single +5 V supply and consumes 69 mA, is well matched to 50Ω, and comes in a small, low-profile 1.5x1.5 mm QFN-style package for ease of integration into dense circuit board layouts.

KEY FEATURES

| Features | Advantages |
|---|--|
| Low Power Consumption, Typ. 69 mA at +5 V | At only 69 mA, this amplifier is ideal for applications with limited available power or densely packed applications where thermal and power management is critical. |
| High Dynamic Range <ul style="list-style-type: none"> • OIP3, Typ. +30 dBm at 3 GHz • P1dB, Typ. +16.6 dBm at 3 GHz | The LEE1-63+ matches industry leading OIP3 performance relative to device size and power consumption. The combination of its low noise figure, high-linearity and output power features make this gain block amplifier ideal for use as secondary stage amplifier in ultra-high dynamic range receivers. |
| 1.5x1.5 mm 6-Lead QFN-Style Package | Very small footprint saves space in dense PCB layouts while providing low inductance, repeatable transitions, and excellent thermal contact with the PCB. Industry standard packaging allows for ease of assembly in high volume manufacturing processes. |
| No External Matching Components Required | The LEE1-63+ features excellent input and output return loss, eliminating the need for any external matching components. |



MMIC SURFACE MOUNT

Monolithic Amplifier

LEE1-63+

50Ω DC to 6000 MHz

ELECTRICAL SPECIFICATIONS¹ AT +25°C, I_{DD} = 69 mA, V_{DD} = +5 V, UNLESS NOTED OTHERWISE

| Parameter | Frequency (MHz) | V _{DD} = +5 V | | | Units |
|---|-----------------|------------------------|-------|-------|-------|
| | | Min. | Typ. | Max. | |
| Frequency Range | | DC ⁶ | | 6000 | MHz |
| Gain | 10 | 22.5 | 23.4 | | dB |
| | 1000 | 20.4 | 21.4 | | |
| | 2000 | 19.8 | 20.8 | | |
| | 3000 | 18.4 | 19.5 | | |
| | 4000 | 16.6 | 17.7 | | |
| | 6000 | 12.8 | 14.0 | | |
| Input Return Loss | 10 | | 14 | | dB |
| | 1000 | | 23 | | |
| | 2000 | | 43 | | |
| | 3000 | | 22 | | |
| | 4000 | | 16 | | |
| | 6000 | | 11 | | |
| Output Return Loss | 10 | | 9 | | dB |
| | 1000 | | 19 | | |
| | 2000 | | 16 | | |
| | 3000 | | 15 | | |
| | 4000 | | 15 | | |
| | 6000 | | 14 | | |
| Isolation | 10 - 6000 | | 23 | | dB |
| Output Power at 1 dB Compression (P _{1dB}) | 10 | | +18.8 | | dBm |
| | 1000 | | +19.3 | | |
| | 2000 | | +18.6 | | |
| | 3000 | | +16.6 | | |
| | 4000 | | +15.2 | | |
| | 6000 | | +11.8 | | |
| Output Third-Order Intercept Point (P _{OUT} = 0 dBm/Tone) | 10 | | +32.0 | | dBm |
| | 1000 | | +34.0 | | |
| | 2000 | | +32.5 | | |
| | 3000 | | +30.0 | | |
| | 4000 | | +28.4 | | |
| | 6000 | | +26.1 | | |
| Noise Figure | 10 | | 3.5 | | dB |
| | 1000 | | 3.5 | | |
| | 2000 | | 3.4 | | |
| | 3000 | | 3.4 | | |
| | 4000 | | 3.5 | | |
| | 6000 | | 4.0 | | |
| Device Operating Voltage (V _{DD}) ² | | +4.75 | +5.0 | +5.25 | V |
| Device Operating Current (I _{DD}) ³ | | | 69 | | mA |
| Device Current Variation vs. Temperature ⁴ | | | 0.049 | | mA/°C |
| Device Current Variation vs. Voltage ⁵ | | | 0.037 | | mA/mV |

1. Tested on Mini-Circuits Characterization Test Board MB-225-63C+. See Figure 2. Board loss de-embedded to the device.

2. Operating Voltage applied to device LEE1-63+.

3. Current at P_N = -25 dBm.

4. (Current at +105°C - Current at -55°C) / (+105°C - -55°C)

5. (Current at +5.25 V - Current at +4.75 V) / (5.25 V - 4.75 V)

6. Low frequency cut off determined by external coupling capacitors.





TYPICAL PERFORMANCE GRAPHS

Note: The following data was taken on the Mini-Circuits Characterization Test Board MB-225-63C+ (Figure 2).

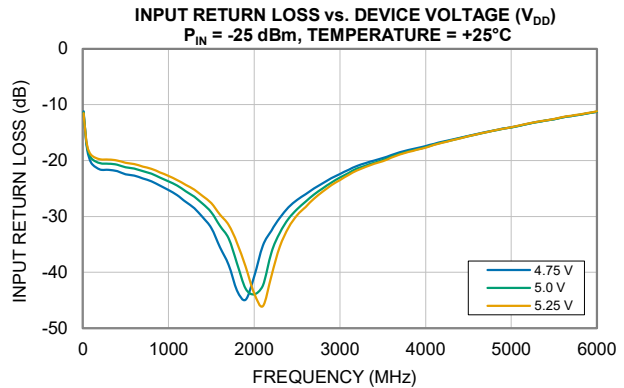
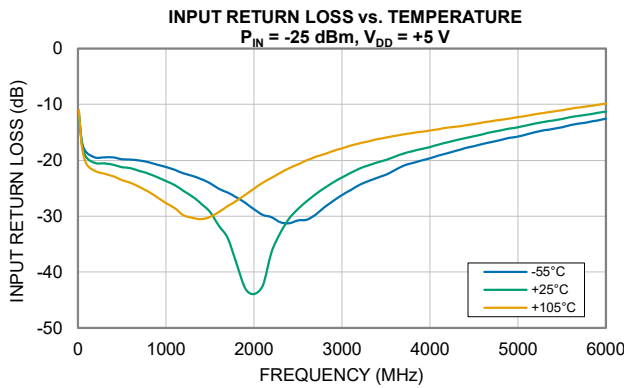
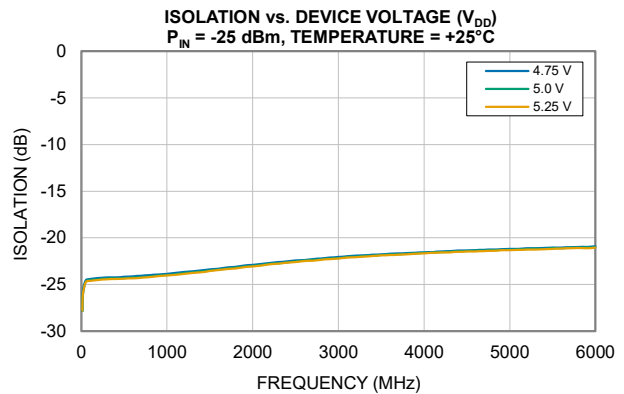
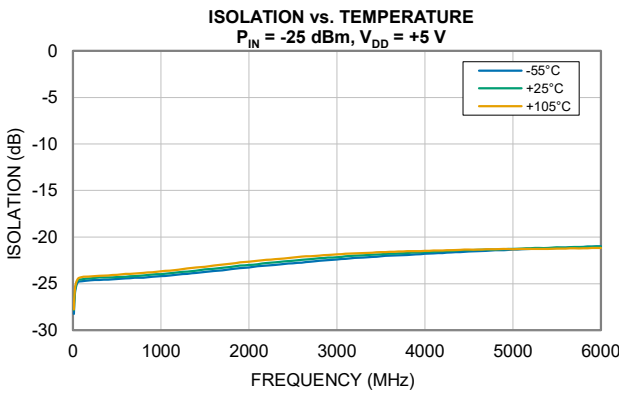
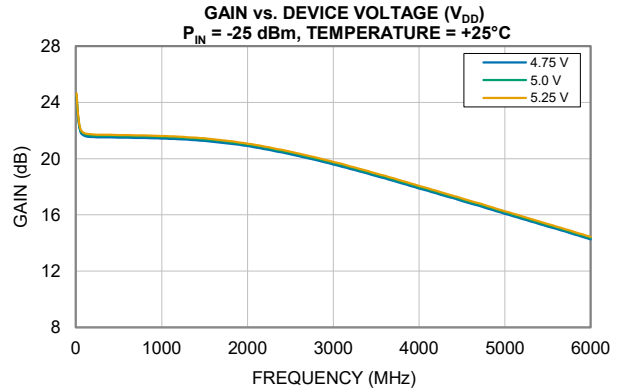
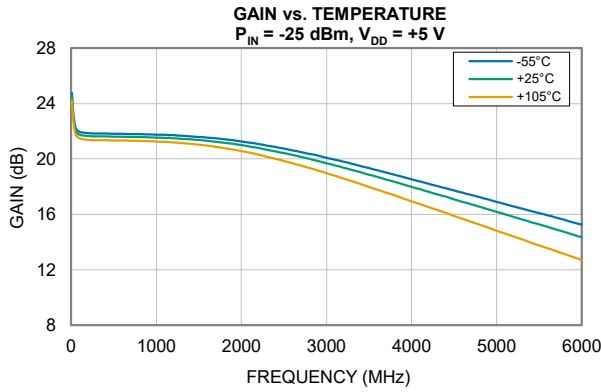



TYPICAL PERFORMANCE GRAPHS

Note: The following data was taken on the Mini-Circuits Characterization Test Board MB-225-63C+ (Figure 2).

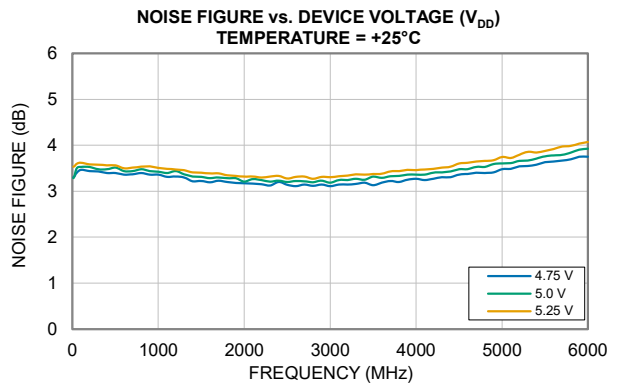
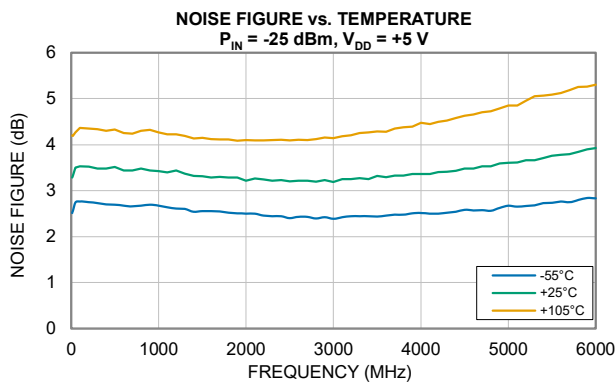
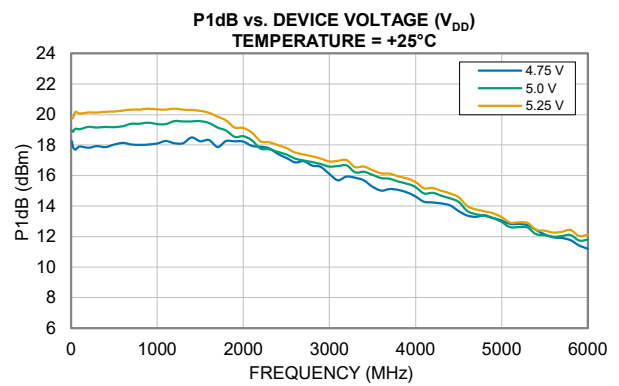
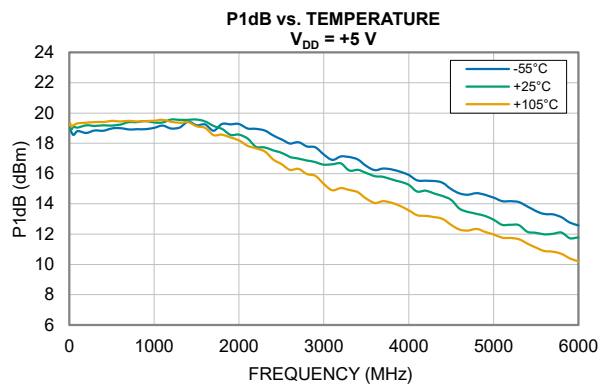
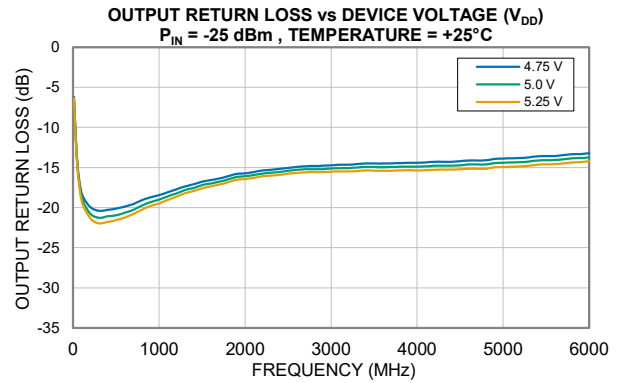
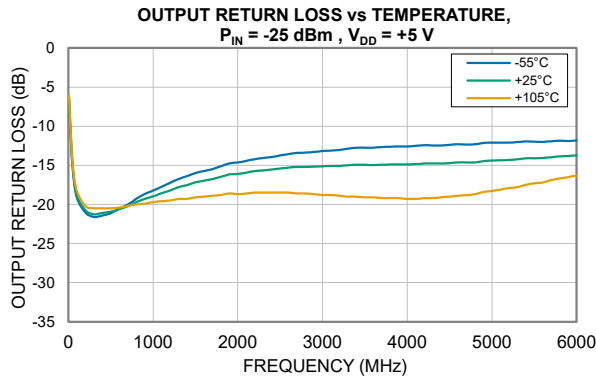



TYPICAL PERFORMANCE GRAPHS

Note: The following data was taken on the Mini-Circuits Characterization Test Board MB-225-63C+ (Figure 2).

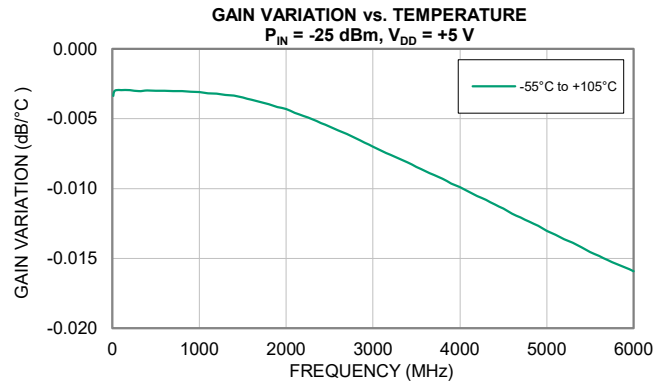
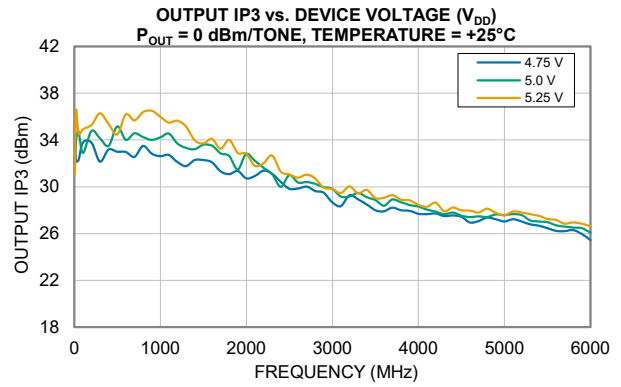
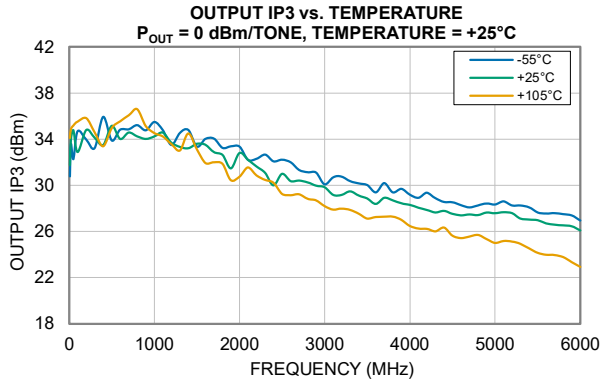



MMIC SURFACE MOUNT

Monolithic Amplifier

LEE1-63+

Mini-Circuits

50Ω DC to 6000 MHz

ABSOLUTE MAXIMUM RATINGS⁷

| Parameter | Ratings |
|--|-----------------|
| Operating Temperature | -55°C to +105°C |
| Storage Temperature | -65°C to +150°C |
| Junction Temperature ⁸ | +150°C |
| Total Power Dissipation | 0.43 W |
| Input Power (CW), V _{DD} = +5 V | +13 dBm |
| DC Voltage at V _{DD} | +6 V |
| DC Current I _{DD} | 110 mA |

7. Permanent damage may occur if any of these limits are exceeded. Maximum ratings are not intended for continuous normal operation.

8. Peak temperature on top of Die.

THERMAL RESISTANCE

| Parameter | Ratings |
|--|-----------|
| Thermal Resistance (Θ _{JC}) ⁹ | 105.2°C/W |

9. Θ_{JC} = (Hot Spot Temperature on Die - Temperature at Ground Lead)/Dissipated Power

ESD RATING

| | Class | Voltage Range | Reference Standard |
|-----|-------|---------------|-----------------------------|
| HBM | 1C | > 1000 V | ANSI/ESDA/JEDEC JS-001-2023 |
| CDM | C3 | > 1000 V | ANSI/ESDA/JEDEC JS-002-2022 |



ESD HANDLING PRECAUTION: This device is designed to be Class 1C for HBM. Static charges may easily produce potentials higher than this with improper handling and can discharge into DUT and damage it. As a preventive measure industry standard ESD handling precautions should be used at all times to protect the device from ESD damage.

MSL RATING

Moisture Sensitivity: MSL1 in accordance with IPC/JEDEC J-STD-020E /JEDEC J-STD-033C



MMIC SURFACE MOUNT

Monolithic Amplifier

LEE1-63+

Mini-Circuits

50Ω DC to 6000 MHz

FUNCTIONAL DIAGRAM (TOP VIEW)

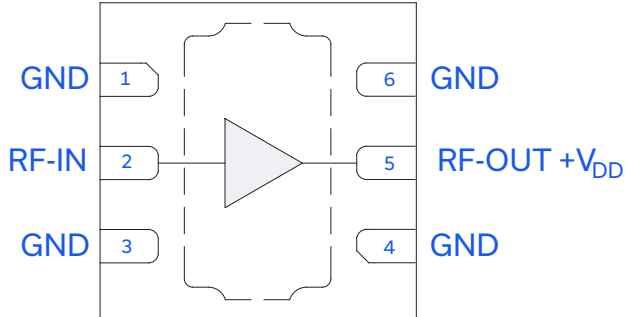

Figure 1. LEE1-63+ Functional Diagram

PAD DESCRIPTION

| Function | Pad Number | Description (Refer to Fig 2) |
|------------------------|---------------------|--|
| RF-IN | 2 | RF-IN Pad connects to RF Input port. |
| RF-OUT+V _{DD} | 5 | RF-OUT Pad connects to RF Output port. V _{DD} is applied via external bias tee. |
| GND | 1, 3, 4, 6 & Paddle | Connects to ground. |

CHARACTERIZATION TEST BOARD

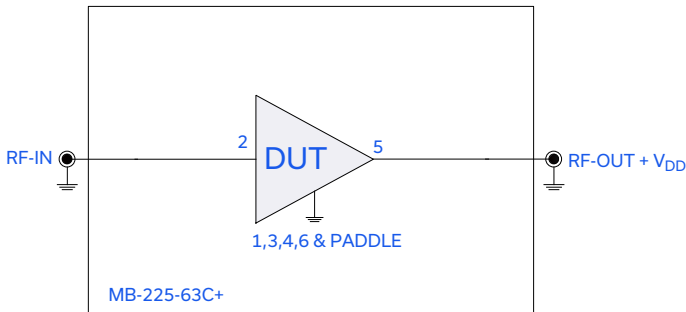

Figure 2. LEE1-63+ Characterization Circuit

Electrical Parameters and Conditions

Gain, Return Loss, Output Power at 1dB Compression (P1dB), Output IP3 (OIP3), and Noise Figure measured using N5242A PNA-X microwave network analyzer.

Conditions:

1. Gain and Return Loss: P_{IN} = -25 dBm
2. Output IP3 (OIP3): Two tones, spaced 1 MHz apart, 0 dBm/Tone at output.
3. V_{DD} = +5 V



EVALUATION BOARD

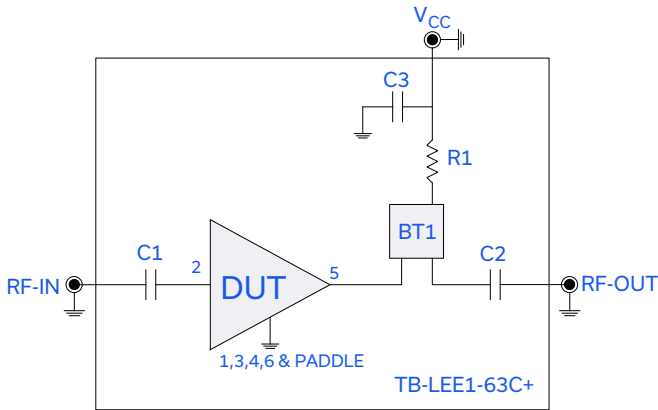

Figure 3. LEE1-63+ Evaluation Circuit

Electrical Parameters and Conditions

Gain, Return Loss, Output Power at 1dB Compression (P1dB), Output IP3 (OIP3), and Noise Figure measured using N5242A PNA-X microwave network analyzer.

Conditions:

1. Gain and Return Loss: $P_{IN} = -25$ dBm
2. Output IP3 (OIP3): Two tones, spaced 1 MHz apart, 0 dBm/Tone at output.
3. $V_{CC} = +5$ V

| Component | Value | Size | Part Number | Manufacturer |
|-----------|-------------------|------------|--------------------|---------------|
| C1, C2 | 2.4 nF | 0402 | GRM1557U1A242JA1D | Murata |
| C3 | 0.1 μ F | 0805 | GCM21BR91H104KA37L | Murata |
| R1 | 0 Ω , 0.5W | 1210 | RC1210FR-070RL | Yageo |
| BT1 | - | 3.8x3.8 mm | TCBT-123+ | Mini-Circuits |



TYPICAL PERFORMANCE GRAPHS

Note: The following data was taken on the Mini-Circuits Evaluation Board TB-LEE1-63C+ (Figure 3).

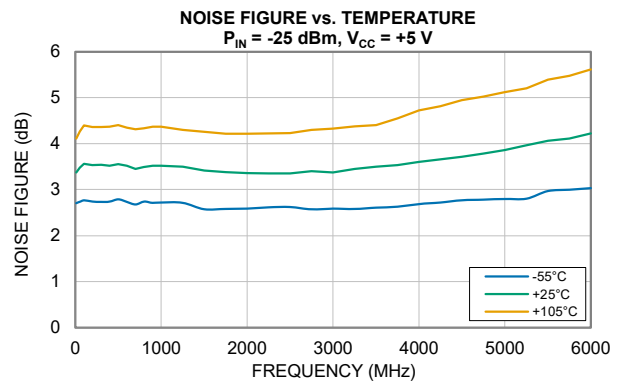
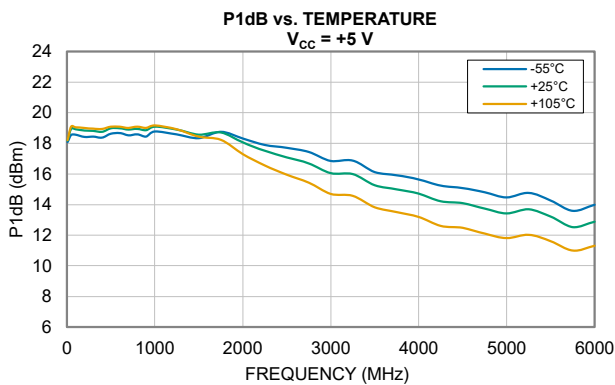
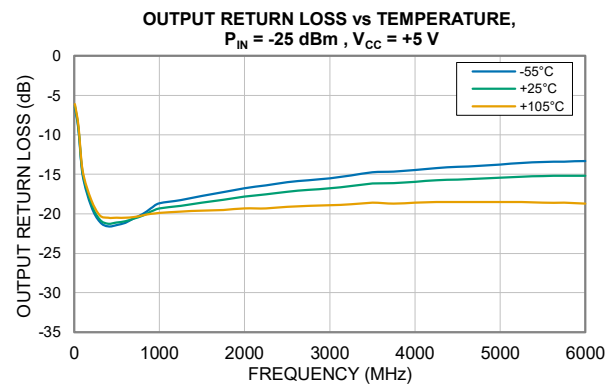
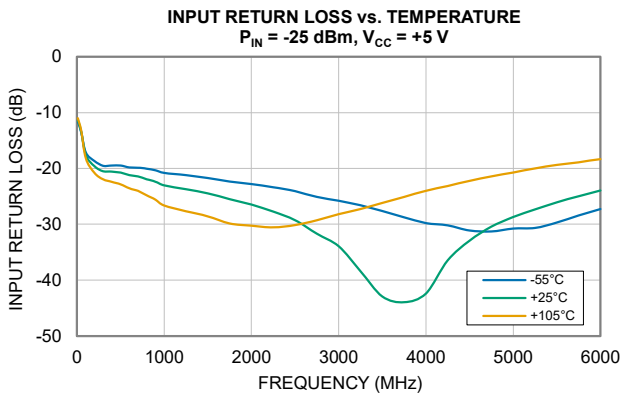
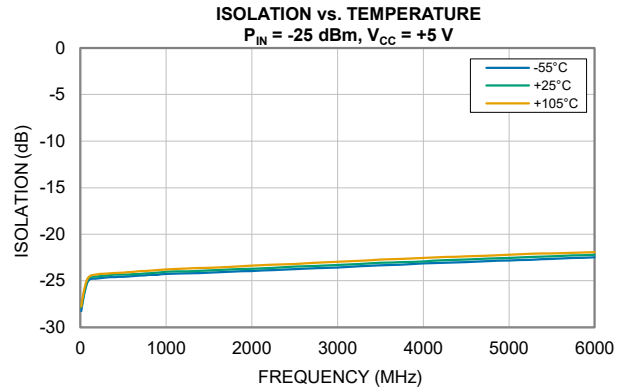
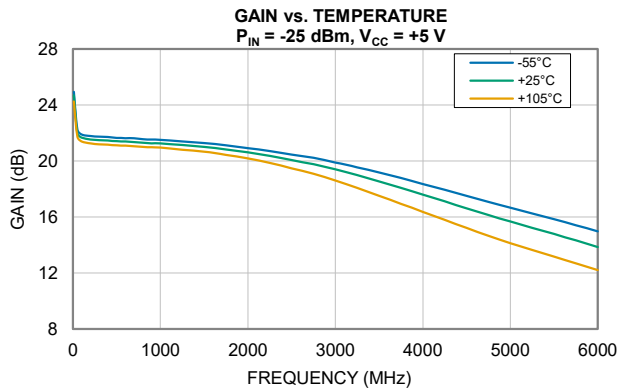



TYPICAL PERFORMANCE GRAPHS

Note: The following data was taken on the Mini-Circuits Evaluation Board TB-LEE1-63C+ (Figure 3).

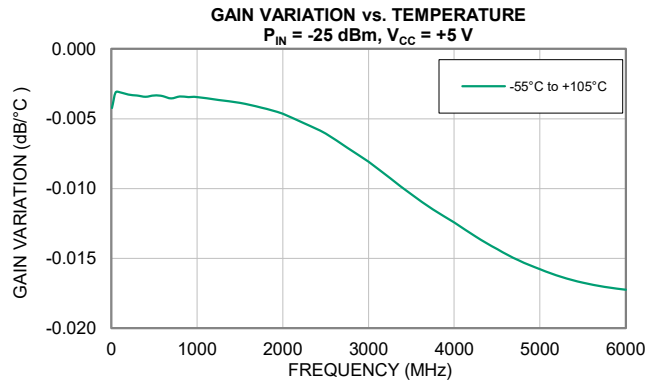
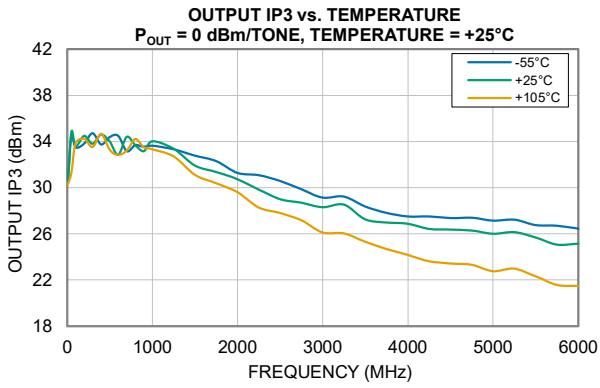



MMIC SURFACE MOUNT

Monolithic Amplifier

LEE1-63+

Mini-Circuits

50Ω DC to 6000 MHz

CASE STYLE DRAWING

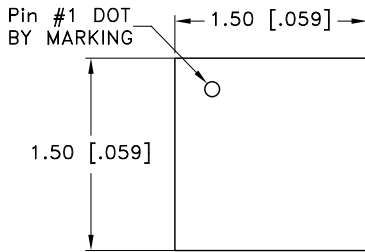

TOP VIEW

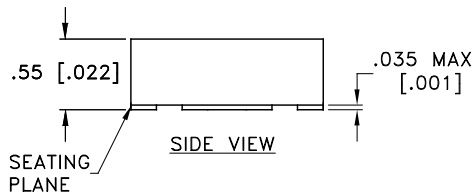

SIDE VIEW

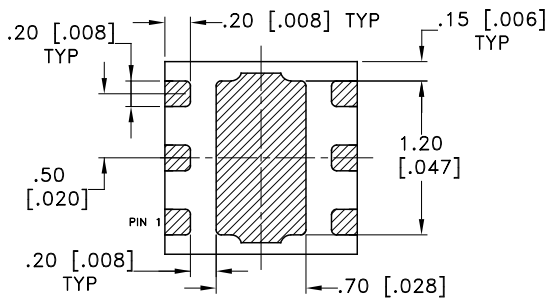

BOTTOM VIEW

PCB Land Pattern

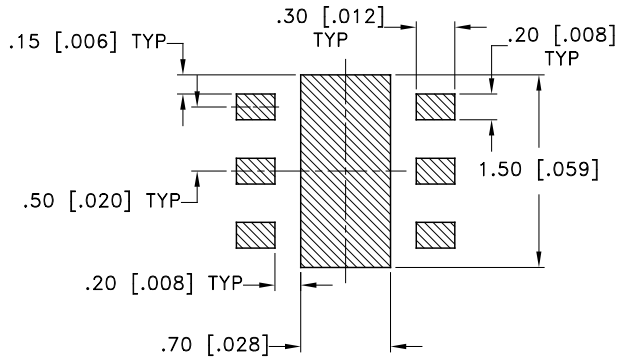

Suggested Layout,
Tolerance to be within ± 0.050 mm

NOTES:

1. DENOTES METALLIZATION

Weight: 0.0036 grams

Dimensions are in mm [inches]. Tolerances: 2Pl. ± 0.05 mm [0.002 inches].

PRODUCT MARKING

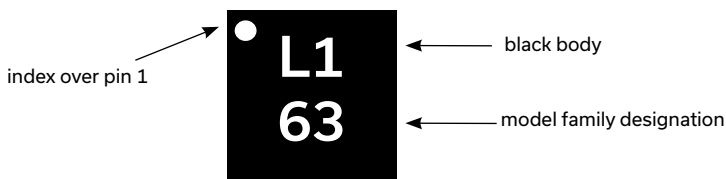

Marking may contain other features or characters for internal lot control



MMIC SURFACE MOUNT

Monolithic Amplifier

LEE1-63+

50Ω DC to 6000 MHz

Mini-Circuits

ADDITIONAL DETAILED INFORMATION IS AVAILABLE ON OUR DASHBOARD

[CLICK HERE](#)

| | |
|---|--|
| Performance Data & Graphs | Data Graphs S-Parameter (S2P Files) Data Set (.zip file) |
| Case Style | KC3011 Plastic package, exposed paddle, Lead Finish: Nickel Palladium Gold |
| RoHS Status | Compliant |
| Tape & Reel Standard quantities available on reel | F66 7" reels with 20, 50, 100, 200, 500, 1000, 2000, or 3000 devices |
| Suggested Layout for PCB Design | PL-851 |
| Evaluation Board | TB-LEE1-63C+ Gerber File |
| Environmental Ratings | ENV08T1 |

NOTES

- A. Performance and quality attributes and conditions not expressly stated in this specification document are intended to be excluded and do not form a part of this specification document.
- B. Electrical specifications and performance data contained in this specification document are based on Mini-Circuit's applicable established test performance criteria and measurement instructions.
- C. The parts covered by this specification document are subject to Mini-Circuits standard limited warranty and terms and conditions (collectively, "Standard Terms"); Purchasers of this part are entitled to the rights and benefits contained therein. For a full statement of the standard terms and the exclusive rights and remedies thereunder, please visit Mini-Circuits' website at www.minicircuits.com/terms/viewterm.html

