

Ceramic Low Pass Filter

50Ω DC⁽¹⁾ to 2400 MHz

LFCN-2400-12+

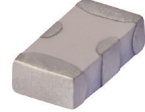

Generic photo used for illustration purposes only
CASE STYLE: FV1206

+RoHS Compliant

The +Suffix identifies RoHS Compliance. See our web site for RoHS Compliance methodologies and qualifications



Available Tape and Reel at no extra cost

Reel Size	Devices/Reel
7"	20, 50, 100, 200, 500, 1000, 3000

Maximum Ratings

Operating Temperature	-55°C to 100°C
Storage Temperature	-55°C to 100°C
RF Power Input*	9W max. at 25°C

* Passband rating, derate linearly to 4W at 100°C ambient. Permanent damage may occur if any of these limits are exceeded.

Pin Connections

RF IN	1
RF OUT	3
GROUND	2,4

Outline Drawing

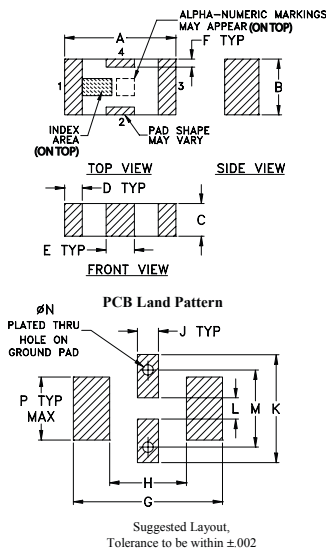

Outline Dimensions (inch/mm)

A	B	C	D	E	F	G	
.126	.063	.037	.020	.032	.009	.169	
3.20	1.60	0.94	0.51	0.81	0.23	4.29	
H	J	K	L	M	N	P	wt
.087	.024	.122	.024	.087	.012	.071	grams
2.21	0.61	3.10	0.61	2.21	0.30	1.80	.020

Demo Board MCL P/N: TB-270 Suggested PCB Layout (PL-137)

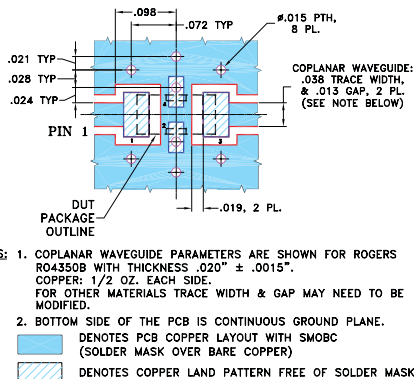

Features

- excellent power handling, 9W
- small size
- 5 sections
- temperature stable
- LTCC construction

Applications

- harmonic rejection
- VHF/UHF transmitters/receivers
- lab use

Electrical Specifications^(1,2) at 25°C

Parameter	F#	Frequency (MHz)	Min.	Typ.	Max.	Unit	
Pass Band	Insertion Loss	DC-F1	DC-2400	—	—	1.5	dB
	Freq. Cut-Off	F2	2800	—	3.0	—	dB
	VSWR	DC-F1	DC-2400	—	1.2	—	:1
Stop Band	Rejection Loss	F3	3600	20	—	—	dB
		F4-F5	3700-4000	—	30	—	dB
		F6	5000	—	20	—	dB
	VSWR	F3-F6	3600-5000	—	20	—	:1

(1) In Applications where DC isolation to ground is required, coupling capacitors are recommended to avoid DC leakage. Alternatively, if DC pass IN-OUT is required, Mini-Circuits' "D" suffix version of this model will support DC IN-OUT, and provide >100 MOhm isolation to ground.
(2) Measured on Mini-Circuits Characterization Test Board TB-270.

Typical Frequency Response

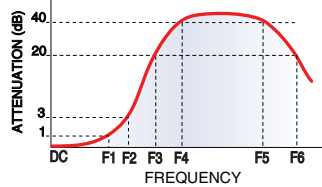

Electrical Schematic

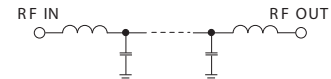

Typical Performance Data at 25°C

Frequency (MHz)	Insertion Loss (dB)	VSWR (:1)
10.00	0.03	1.01
308.75	0.10	1.07
607.50	0.20	1.20
906.25	0.39	1.31
1205.00	0.41	1.19
1503.75	0.41	1.17
1802.50	0.46	1.13
2101.25	0.62	1.25
2400.00	1.34	1.97
2850.00	6.94	8.51
3000.00	10.53	14.15
3300.00	19.58	37.77
3600.00	38.18	115.81
4222.22	23.66	78.97
5000.00	19.90	34.75

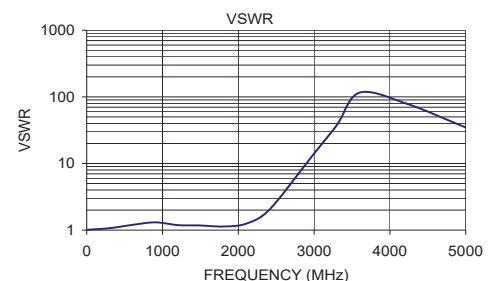
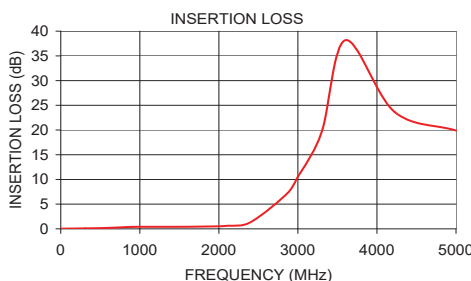

Notes

- Performance and quality attributes and conditions not expressly stated in this specification document are intended to be excluded and do not form a part of this specification document.
- Electrical specifications and performance data contained in this specification document are based on Mini-Circuit's applicable established test performance criteria and measurement instructions.
- The parts covered by this specification document are subject to Mini-Circuits standard limited warranty and terms and conditions (collectively, "Standard Terms"); Purchasers of this part are entitled to the rights and benefits contained therein. For a full statement of the Standard Terms and the exclusive rights and remedies thereunder, please visit Mini-Circuits' website at www.minicircuits.com/MCLStore/terms.jsp

Mini-Circuits

www.minicircuits.com P.O. Box 350166, Brooklyn, NY 11235-0003 (718) 934-4500 sales@minicircuits.com

REV. OR
NPO-001807
LFCN-2400-12+
ED-9913/5
AD/CP/AM
210623