

# Power Splitter/Combiner

## LRPS-2-25

2 Way-0° 50Ω 1700 to 2500 MHz



Generic photo used for illustration purposes only

CASE STYLE: QQQ130

### Maximum Ratings

Operating Temperature	-40°C to 85°C
Storage Temperature	-55°C to 100°C
Power Input (as a splitter)	1W max.
Internal Dissipation	0.125W max.

Permanent damage may occur if any of these limits are exceeded.

### Pin Connections

SUM PORT	6
PORT 1	4
PORT 2	3
GROUND	1,2,5

### Outline Drawing

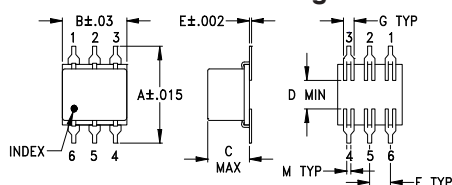

### PCB Land Pattern

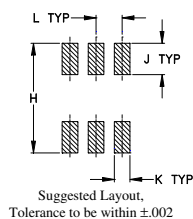

### Outline Dimensions (inch/mm)

A	B	C	D	E	F	G
.400	.31	.200	.10	.010	.100	.050
10.16	7.87	5.08	2.54	0.25	2.54	1.27
H	J	K	L	M		wt
.420	.120	.060	.100	.020		grams
10.67	3.05	1.52	2.54	0.51		0.55

### Demo Board MCL P/N: TB-100 Suggested PCB Layout (PL-057)

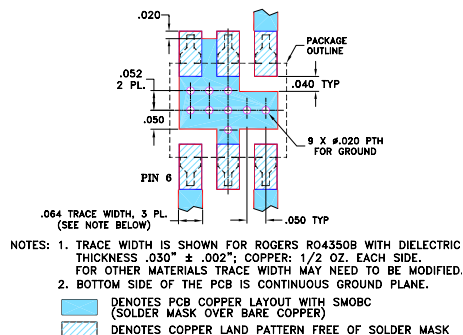

### Notes

A. Performance and quality attributes and conditions not expressly stated in this specification document are intended to be excluded and do not form a part of this specification document.  
 B. Electrical specifications and performance data contained in this specification document are based on Mini-Circuit's applicable established test performance criteria and measurement instructions.  
 C. The parts covered by this specification document are subject to Mini-Circuits standard limited warranty and terms and conditions (collectively, "Standard Terms"); Purchasers of this part are entitled to the rights and benefits contained therein. For a full statement of the Standard Terms and the exclusive rights and remedies thereunder, please visit Mini-Circuits' website at [www.minicircuits.com/MCLStore/terms.jsp](http://www.minicircuits.com/MCLStore/terms.jsp)

### Features

- low insertion loss, 0.8 dB typ.
- good isolation, 20 dB typ.

### Applications

- PCS
- DCS
- ISM
- communications systems

### Electrical Specifications

FREQ. RANGE (MHz)	ISOLATION (dB)		INSERTION LOSS (dB) ABOVE 3.0 dB		PHASE UNBALANCE (Degrees)	AMPLITUDE UNBALANCE (dB)
	Typ.	Min.	Typ.	Max.	Max.	Max.
$f_c - f_u$	20	16	0.8	1.3	10	0.9
1700-2500						

### Typical Performance Data

Frequency (MHz)	Total Loss <sup>1</sup> (dB)		Amplitude Unbalance (dB)	Isolation (dB)	Phase Unbalance (deg.)	VSWR S	VSWR 1	VSWR 2
	S-1	S-2						
1700.00	3.55	3.45	0.10	17.17	1.63	1.43	1.14	1.15
1732.00	3.55	3.45	0.10	17.52	1.55	1.40	1.13	1.16
1764.00	3.54	3.45	0.09	17.89	1.53	1.38	1.13	1.17
1828.00	3.53	3.46	0.07	18.73	1.43	1.35	1.12	1.19
1892.00	3.52	3.46	0.07	19.69	1.24	1.31	1.12	1.21
1956.00	3.52	3.47	0.05	20.83	1.13	1.28	1.12	1.25
2020.00	3.53	3.48	0.05	22.18	0.94	1.26	1.12	1.27
2084.00	3.53	3.49	0.04	23.91	0.75	1.25	1.11	1.30
2148.00	3.55	3.51	0.04	26.14	0.50	1.25	1.12	1.33
2212.00	3.56	3.54	0.02	29.31	0.34	1.25	1.12	1.36
2276.00	3.59	3.57	0.03	34.50	0.11	1.30	1.13	1.40
2340.00	3.63	3.61	0.03	40.88	0.21	1.32	1.14	1.43
2404.00	3.68	3.65	0.03	34.00	0.40	1.38	1.15	1.47
2468.00	3.74	3.70	0.03	28.52	0.79	1.44	1.16	1.51
2500.00	3.77	3.73	0.03	26.61	0.93	1.49	1.17	1.53

1. Total Loss = Insertion Loss + 3dB splitter loss.

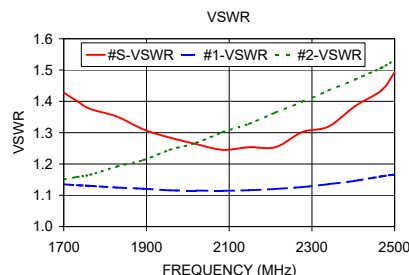
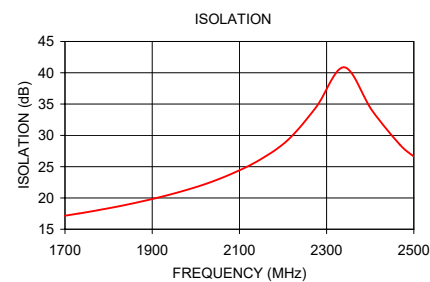
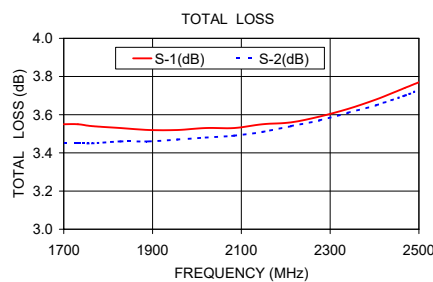

### electrical schematic

