

# Nano-Second Switching SPDT RF Switch

## M3SWA2-63DRC+

Absorptive RF Switch with internal driver

### The Big Deal

- High Isolation, 63 dB typ. at 1GHz
- High IIP3, +44dBm typ. at 1GHz
- Low insertion loss, 0.5 dB typ. at 1GHz
- Fast Rise/Fall time, 5.6 ns / 6 ns typ.
- Tiny Size, 3x3mm 12L MCLP

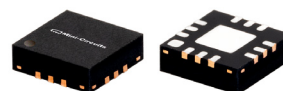

CASE STYLE: DQ1225

### Product Overview

Mini-Circuits' M3SWA2-63DRC+ is a MMIC SPDT absorptive switch with an internal driver designed for wideband operation from DC to 6 GHz supporting many applications requiring nano-second switching across a wide frequency range. This model provides excellent isolation and high linearity and is packaged in a 3x3mm 12L package.

### Key Features

Feature	Advantages
Wideband, DC to 6 GHz	One model can be used in many applications, saving component count. Also ideal for wideband applications such as military and instrumentation.
Absorptive switch	In the OFF condition, RF output ports which are not switched ON are terminated into 50Ω. This enables proper impedance termination of the circuitry following the RF output ports, preventing any unintended action such as oscillation.
High Isolation: <ul style="list-style-type: none"><li>• 63 dB at 1 GHz</li><li>• 29 dB at 6 GHz</li></ul>	High isolation significantly reduces leakage of power into OFF ports.
High linearity: Pin at P1dB, 26.2dBm typ. at 1GHz	High linearity minimizes unwanted intermodulation products which are difficult or impossible to filter in multi-carrier environments such as CATV, or in the presence of strong interfering signal from adjacent circuitry or received by antenna.
Tiny size, 3 x 3 mm MCLP package	Tiny footprint saves space in dense layouts while providing low inductance, repeatable transitions, and excellent thermal contact to the PCB.



# Nano-Second Switching SPDT RF Switch

50Ω DC - 6000 MHz

Absorptive RF Switch with internal driver

## Product Features

- High Isolation, 63 dB typ. at 1GHz
- Low Insertion Loss, 0.5dB typ. at 1GHz
- Fast Rise/Fall time, 5.6ns/ 6ns typ.
- High Input IP3, +44dBm typ. at 1GHz
- Replaces M3SWA-2-50DR+

## Typical Applications

- Defense
- Communication Infrastructure
- Test and Measurements

## M3SWA2-63DRC+

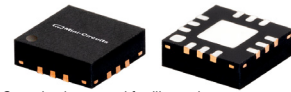

Generic photo used for illustration purposes only

CASE STYLE: DQ1225

### +RoHS Compliant

The +Suffix identifies RoHS Compliance. See our web site for RoHS Compliance methodologies and qualifications

## General Description

Mini-Circuits' M3SWA2-63DRC+ is a MMIC SPDT absorptive switch with an internal driver designed for wideband operation from DC to 6 GHz supporting many applications requiring nano-second switching across a wide frequency range. This model provides excellent isolation and high linearity and is packaged in a 3x3mm 12L package.

## Simplified Schematic and Pad Description

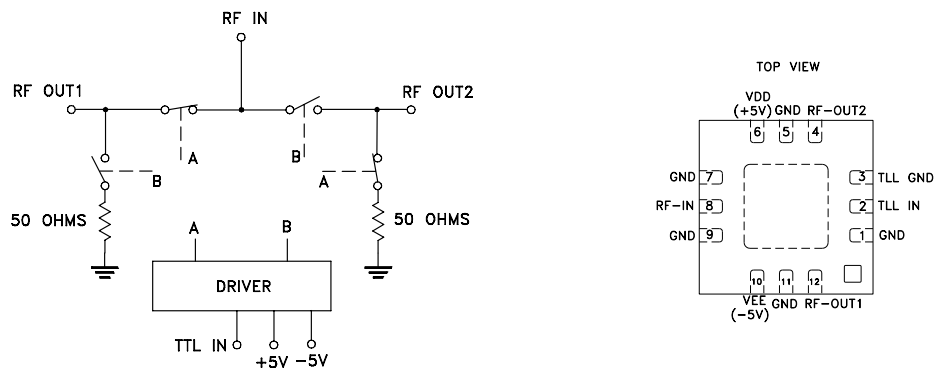

Function	Pad Number	Description
RF-IN	8	RF Common/ SUM port
RF-OUT1	12	RF Output port #1
RF-OUT2	4	RF Output port #2
TTL IN	2	TTL Compatible Control Voltage Input
TTL GND	3	TTL Ground
V <sub>DD</sub> (+5V)	6	Positive Supply Voltage V <sub>DD</sub>
V <sub>EE</sub> (-5V)	10	Negative Supply Voltage V <sub>EE</sub>
GND	1,5,7,9,11, paddle	Ground



RF Electrical Specifications<sup>1</sup>, T<sub>AMB</sub>=25°C, 50Ω, V<sub>DD</sub>= +5V, V<sub>EE</sub>= -5V

Parameter	Condition (MHz)	Min.	Typ.	Max.	Units
Frequency range <sup>3</sup>		DC		6000	MHz
Insertion loss	10 - 100	—	0.4	1.0	dB
	100 - 1000	—	0.5	1.2	
	1000 - 2000	—	0.6	1.4	
	2000 - 4500	—	0.8	2.0	
	4500 - 6000	—	1.3	2.2	
Isolation between Output Port 1 & 2	10 - 100	65	78		dB
	100 - 1000	53	63		
	1000 - 2000	45	55		
	2000 - 4500	30	46		
	4500 - 6000	29	37		
Isolation between Common Port & Output Ports	10 - 100		88		dB
	100 - 1000		77		
	1000 - 2000		56		
	2000 - 4500		42		
	4500 - 6000		32		
Input Return loss	10 - 100		30		dB
	100 - 1000		30		
	1000 - 2000		29		
	2000 - 4500		28		
	4500 - 6000		15		
Output Return loss (Both ON STATE & OFF STATE)	10 - 100		30		dB
	100 - 1000		29		
	1000 - 2000		29		
	2000 - 4500		28		
	4500 - 6000		15		
Input Power at P1dB <sup>2</sup>	10 - 100		16.7		dBm
	100 - 1000		24.4		
	1000 - 2000		26.2		
	2000 - 4500		25.6		
	4500 - 6000		25.6		
Input IP3 (Pout=0 dBm/Tone)	10 - 100		38.4		dBm
	100 - 1000		44.5		
	1000 - 2000		46.3		
	2000 - 4500		45.7		
	4500 - 6000		43.8		
Thermal Resistance - Junction-to-ground lead at 85°C stage temperature			34.2		°C/W

## DC Electrical Specifications

Parameter	Min.	Typ.	Max.	Units
Positive Supply Voltage, V <sub>DD</sub>	4.75	5	5.25	V
Negative Supply voltage, V <sub>EE</sub>	-5.25	-5	-4.75	V
Positive Supply Current, I <sub>DD</sub>	—	4	9	mA
Negative Supply Current, I <sub>EE</sub>	—	3	9	mA
Control Voltage Low	—	0	0.8	V
Control Voltage High	2.3	—	5	V
Control Current Low	—	2	200	μA
Control Current High	—	0.4	5	mA

1. Tested on Mini-Circuits' test board TB-M3SWA2-63DRC+ (See Fig.1)
2. Input Power at P1dB compression drops to 11 dB at 10 MHz.
3. All RF-ports must be DC blocked or held at 0V DC.

## Switching Specifications

Parameter	Condition	Min.	Typ.	Max.	Units	
ON Time, 50% control to 90% RF	RF Pin= 0 dBm RF Freq.= 500 MHz Control Freq.= 500 KHz Control High= 2.3V Control Low= 0V		9.3		ns	
OFF Time, 50% control to 10% RF			8.5		ns	
Video Leakage				25		mV
Rise Time, 10% RF to 90% RF 10 to 90% or 90 to 10%				5.6		ns
Fall Time, 90% RF to 10% RF				6.0		ns
Gate Lag, ON & OFF				7.4		ns



**Absolute Maximum Ratings<sup>4</sup>**

Parameter	Ratings
Operating temperature	-55°C to +100°C
Storage temperature	-55°C to +100°C
RF Power Max at Input Port	27 dBm
RF Power Max at Output Port (for each port)	24 dBm
Junction Temperature	150°C
Total Power Dissipation	0.4W
DC Voltage, Pad 6	+6V
DC Voltage, Pad 10	-6V

4. Permanent damage may occur if any of these limits are exceeded. Electrical Maximum ratings are not intended for continuous normal operation.

**Truth Table**

State of Control Voltage	RF-IN to RF-OUT1	RF-IN to RF-OUT 2
LOW	ON	OFF
HIGH	OFF	ON

**Characterization & Application Circuit**

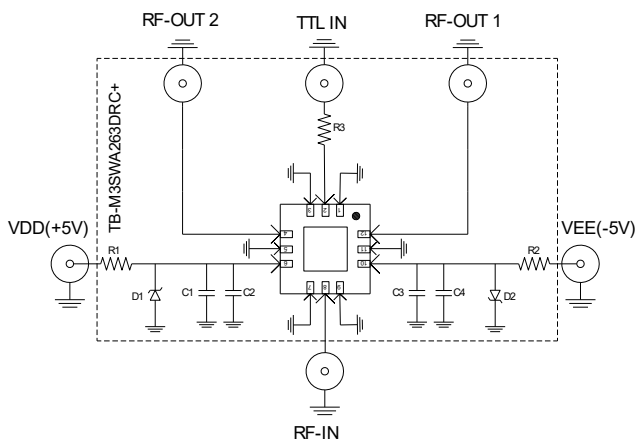

Component	Size	Value	Part Number	Manufacturer
C2,C3	0402	0.5pF	GRM1555C1HR50BA01D	Murata
C1,C4	0402	1pF	GJM1555C1H1R0CB01D	Murata
R1,R2	0402	11.50ohm	RP73PF1E11R5BTD	TE Connectivity
R3	0402	100Ohm	RK73H1ETTP1000F	Koa
D1,D2	SOD-123	Vz=5.6V	SZMMSZ5232BT1G	ON Semiconductor

Note: D1&D2 are optional.

**Figure 1. Characterization & Application Circuit**

Note: (DUT soldered on Mini-Circuits Characterization & Application Test Board TB-M3SWA2-63DRC+). Insertion Loss, Isolation, Return Loss, Input Power at 1dB Compression (P1dB) & Input IP3 tested using E5071C microwave network analyzer.

Condition:

1. Insertion Loss, Isolation & Return Loss: Pin = 0dBm
2. Input IP3(IIP3): Two tones, spaced 1 MHz apart, 0dBm/tone output.

**Product Marking**



Marking may contain other features or characters for internal lot control

**Additional Detailed Technical Information**

*additional information is available on our dash board.*

<b>Performance Data</b>	Data Table
	Swept Graphs
<b>Case Style</b>	DQ1225 Plastic package, exposed paddle , lead finish=Matte-Tin
<b>Tape &amp; Reel</b> Standard quantities available on reel	F66 7" reels with 20, 50, 100, 200, 500, or 1K devices
<b>Suggested Layout for PCB Design</b>	PL-682
<b>Evaluation Board</b>	TB-M3SWA2-63DRC+
<b>Environmental Ratings</b>	ENV16

**ESD Rating**

Human Body Model (HBM): Class 1A (Pass 300V) in accordance with ESD STM5.1-2001

**MSL Rating**

Moisture Sensitivity: MSL1 in accordance with IPC/JEDEC J-STD-020D

**MSL Test Flow Chart**

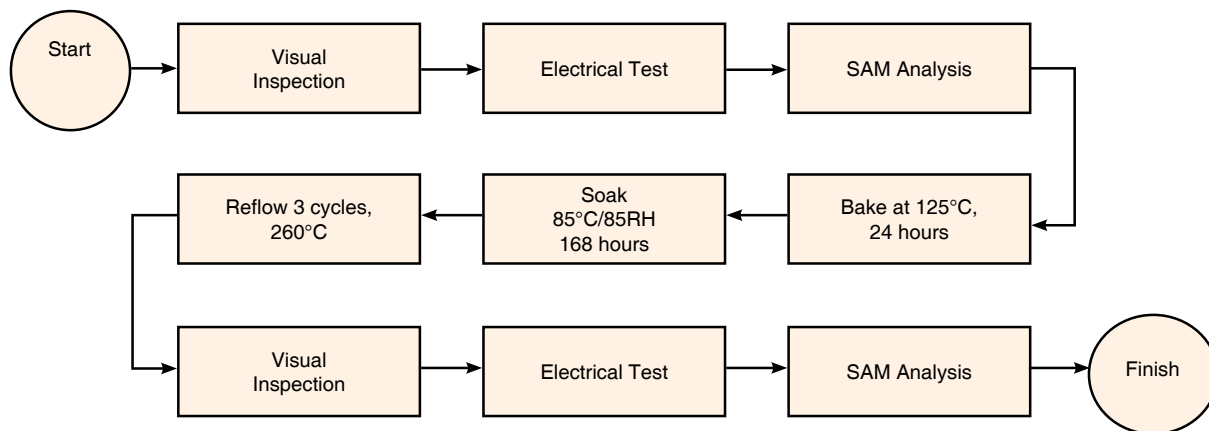

**Additional Notes**

- A. Performance and quality attributes and conditions not expressly stated in this specification document are intended to be excluded and do not form a part of this specification document.
- B. Electrical specifications and performance data contained in this specification document are based on Mini-Circuit's applicable established test performance criteria and measurement instructions.
- C. The parts covered by this specification document are subject to Mini-Circuits standard limited warranty and terms and conditions (collectively, "Standard Terms"); Purchasers of this part are entitled to the rights and benefits contained therein. For a full statement of the Standard Terms and the exclusive rights and remedies thereunder, please visit Mini-Circuits' website at [www.minicircuits.com/MCLStore/terms.jsp](http://www.minicircuits.com/MCLStore/terms.jsp)