

Surface Mount

Dual Matched MMIC Amplifier

MGVA-82+

50Ω

DC to 5.2 GHz

The Big Deal

- Gain, 14.1 dB typ. at 2 GHz
- Dual matched amplifier for push-pull & balanced amplifiers
- High dynamic range

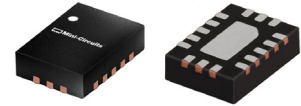

CASE STYLE: JV2579

Product Overview

MGVA-82+ (RoHS compliant) is an advanced wideband amplifier fabricated using InGaP HBT technology and offers high dynamic range over a broad frequency range. In addition, the MGVA-82+ has good input and output return loss over a broad frequency range without the need for external matching components. Lead finish is Matte-Tin and is enclosed in a 3.5 x 2.5 mm, 16-lead MCLP package for good thermal performance.

Key Features

Feature	Advantages
Broadband	Covers many communication bands including cellular, cable TV, PCS, SATCOM, WiMAX, and more.
Excellent Gain Flatness: ±0.6 dB over 0.05-2GHz	Requires no gain compensation in most wideband applications.
Matched pair for use in high IP3 and IP2 amplifiers. Gain match: ± 0.2 dB typ. Phase match: ± 3° typ. to 3 GHz	Enables it to be used in push-pull amplifiers resulting in outstanding IP2.
High IP3, up to 41 dBm	Ideal for suppressing unwanted intermodulation in the presence of multiple carriers, now common in many communication systems.
High P1dB: Up to 17.6 dBm	High P1dB enables the amplifier to operate in linear region in the presence of strong interfering signals.
Medium Noise Figure: 6.7-7.7 dB typ.	Together with High OIP3/P1dB, results in high dynamic range



Surface Mount

Dual Matched MMIC Amplifier

DC - 5.2GHz

Product Features

- Two matched amplifiers in one package
- High IP3, +36 dBm at 2 GHz
- High IP2, +44 dBm at 2 GHz in push-pull configuration
- Gain, 14.1 dB typ at 2 GHz
- Excellent Gain flatness, ±0.6 dB (0.05-2 GHz)
- P1dB, +20 dBm typ at 2 GHz



Generic photo used for illustration purposes only

MGVA-82+

CASE STYLE: JV2579

Typical Applications

- SATCOM
- CATV
- FTTH
- Optical networks
- Base station infrastructure
- Balanced amplifiers

+RoHS Compliant
The +Suffix identifies RoHS Compliance. See our web site for RoHS Compliance methodologies and qualifications

General Description

MGVA-82+ (RoHS compliant) is an advanced wideband amplifier fabricated using InGaP HBT technology and offers high dynamic range over a broad frequency range. In addition, the MGVA-82+ has good input and output return loss over a broad frequency range without the need for external matching components. Lead finish is Matte-Tin and is enclosed in a 3.5 x 2.5 mm, 16-lead MCLP package for good thermal performance.

simplified schematic (each of A1, A2) and pad description

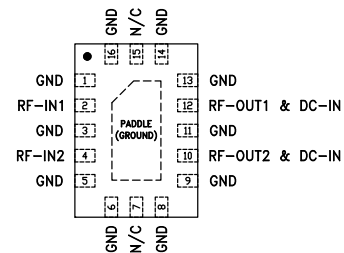
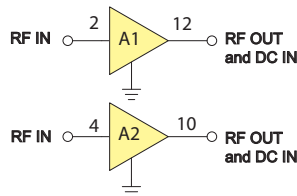

Function	Pad Number	Description
RF-IN1	2	RF input pin. This pin requires the use of an external DC blocking capacitor chosen for the frequency of operation. (see Characterization Test Circuit, Fig 1.)
RF-OUT1 & DC-IN	12	RF output and bias pin. DC voltage is present on this pin; therefore a DC blocking capacitor is necessary for proper operation. An RF choke is needed to feed DC bias without loss of RF signal due to the bias connection, as shown in "Characterization Test Circuit", Fig 1
RF-IN2	4	RF input pin. This pin requires the use of an external DC blocking capacitor chosen for the frequency of operation. (see Characterization Test Circuit, Fig 1.)
RF-OUT2 & DC-IN	10	RF output and bias pin. DC voltage is present on this pin; therefore a DC blocking capacitor is necessary for proper operation. An RF choke is needed to feed DC bias without loss of RF signal due to the bias connection, as shown in "Characterization Test Circuit", Fig 1
GND	1,3,5,6,8,9,11,13,14,16 & paddle	Connections to ground. Use via holes as shown in "Suggested Layout for PCB Design" to reduce ground path inductance for best performance.
N/C	7,15	No Connection

* Enhancement mode pseudomorphic High Electron Mobility Transistor.



Electrical Specifications¹ at 25°C, Zo=50Ω and Device Voltage 5V, unless noted

(Specifications (other than Matching or where defined as push-pull) are for each of the two matched amplifiers in the package)

Parameter	Condition (MHz)	Min.	Typ.	Max.	Units
Frequency Range		DC		5.2	GHz
Gain	50	13.8	15.3	16.8	dB
	1000	—	14.9	—	
	2000	12.2	14.1	15.5	
	3000	—	13.2	—	
	4000	9.8	12.1	13.3	
	5200	—	9.9	—	
Gain Flatness	50 - 2000	—	±0.6	—	dB
Input Return Loss	50		32.4		dB
	1000		23.5		
	2000		17.7		
	3000		15.4		
	4000		13.0		
	5200		9.4		
Output Return Loss	50		16.2		dB
	1000		14.7		
	2000		11.7		
	3000		10.5		
	4000		9.1		
	5200		6.9		
Output power @ 1 dB Compression	50		20.2		dBm
	1000		20.3		
	2000		20.2		
	3000		19.8		
	4000		19.5		
	5200		18.3		
Output IP3	50	—	41	—	dBm
	1000	—	38	—	
	2000	33	36	—	
	3000	—	35	—	
	4000	—	33	—	
	5200	—	32	—	
Output IP2	50	—	55	—	dBm
	1000	—	55	—	
	2000	40	44	—	
	3000	—	41	—	
	4000	—	38	—	
	5200	—	37	—	
Noise Figure	50		6.7		dB
	1000		6.8		
	2000		7.0		
	3000		7.1		
	4000		7.3		
	5200		7.7		
Matching between A1, A2	Amplitude Unbalance	50		0.1	dB
		1000		0.1	
		2000		0.1	
		3000		0.2	
		4000		0.2	
		5200		0.3	
	Phase Unbalance	50		0.1	deg
		1000		1.1	
		2000		1.9	
		3000		3.4	
		4000		6.7	
		5200		9.4	
Device operating voltage		4.8	5.0	5.2	V
Device operating current		—	100	120	mA
Device current variation vs. temperature ⁴			70.5		μA/°C
Device current variation vs voltage ⁵			0.038		mA/mV
Thermal Resistance, junction-to-ground lead			39.4		°C/W

(1) Measured on Mini-Circuits Test Board TB-1002+, see characterization circuit, Fig 1.

(2) $\theta_{jc} = (\text{Junction Temperature} - \text{Ground Pad Temperature}) / (\text{Voltage} \times \text{sum of current in A1 \& A2})$

Absolute Maximum Ratings for each Amplifier⁽³⁾

Parameter	Ratings
Operating Temperature ⁴	-40°C to 85°C
Storage Temperature	-65°C to 150°C
Operating Current at 5V	160 mA
Power Dissipation	0.84 W
Input Power (CW)	20 dBm
DC Voltage (pads 10, 12)	5.8V

⁽³⁾ Permanent damage may occur if any of these limits are exceeded. These ratings are not intended for continuous normal operation.
⁽⁴⁾ Defined with reference to ground pad temperature.

Characterization Test Circuit

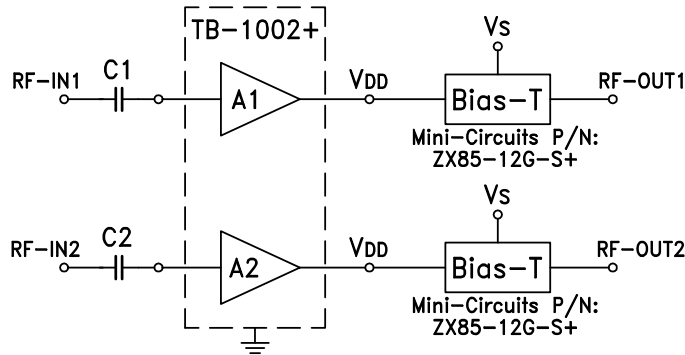

Fig 1. Block Diagram of Test Circuit used for characterization. (DUT tested in Mini-Circuits Test board TB-1002+). Gain, Return loss, Output Power at 1dB compression (P1 dB), output IP3 (OIP3) and noise figure measured using Agilent’s N5242A PNA-X micro-wave network analyzer.

Conditions:

1. Gain and Return loss: Pin= -25dBm
 2. Output IP3 (OIP3) & Output IP2 (OIP2): Two tones, spaced 1MHz apart, 0 dBm/tone at output.
- Note: C1&C2 are PNA built-in DC Blocks.

Product Marking



Marking may contain other features or characters for internal lot control

Additional Detailed Technical Information	
<i>additional information is available on our dash board. To access this information click here</i>	
Performance Data	Data Table
	Swept Graphs
	S-Parameter (S4P Files) Data Set (.zip file)
Case Style	JV2579 <i>Plastic package, exposed paddle lead finish: Matte-Tin plate</i>
Tape & Reel Standard quantities available on reel	F104 <i>7" reels with 2K devices</i>
Suggested Layout for PCB Design	PL-582
Evaluation Board	TB-1002+
Environmental Ratings	ENV08T2

ESD Rating

Human Body Model (HBM): Class 1C (1000 to <2000V) in accordance with ANSI/ESD STM 5.1 - 2001**

** Tested as a single ended amplifier in SOT-89 package.

MSL Test Flow Chart

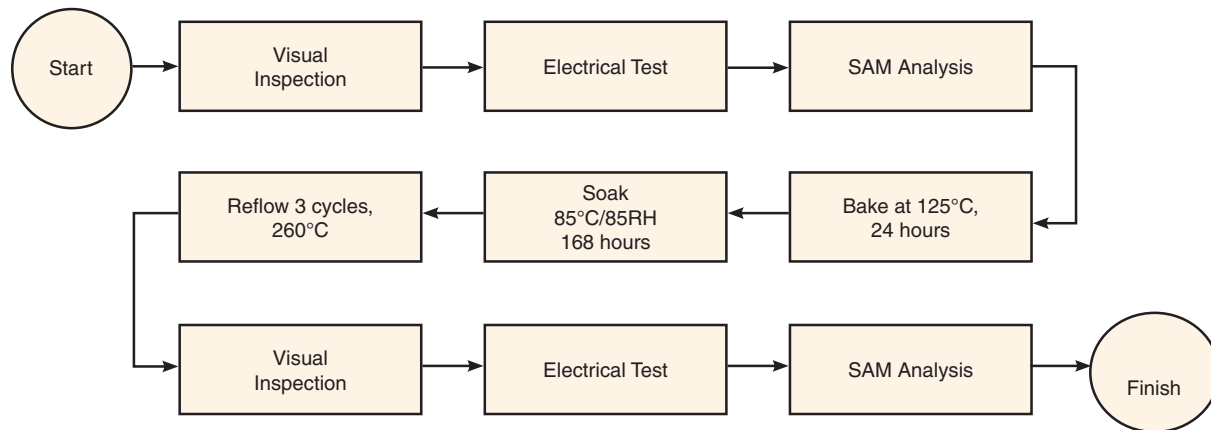

Additional Notes

- A. Performance and quality attributes and conditions not expressly stated in this specification document are intended to be excluded and do not form a part of this specification document.
- B. Electrical specifications and performance data contained in this specification document are based on Mini-Circuit's applicable established test performance criteria and measurement instructions.
- C. The parts covered by this specification document are subject to Mini-Circuits standard limited warranty and terms and conditions (collectively, "Standard Terms"); Purchasers of this part are entitled to the rights and benefits contained therein. For a full statement of the Standard Terms and the exclusive rights and remedies thereunder, please visit Mini-Circuits' website at www.minicircuits.com/MCLStore/terms.jsp