

Surface Mount Switch

50Ω SPDT, Absorptive DC to 2.0 GHz

MSWA-2-20+ MSWA-2-20



CASE STYLE: XX211-1
PRICE: \$2.45 ea. QTY (10)

+ RoHS compliant in accordance with EU Directive (2002/95/EC)

The +suffix identifies RoHS Compliance. See our web site for RoHS compliance methodologies and qualifications.

Maximum Ratings

Operating Temperature	-40°C to 85°C
Storage Temperature	-55°C to 100°C
Input Power	see Note 1
Control Current	see Note 2
Permanent damage may occur if any of these limits are exceeded.	

Pin Connections

RF IN	2
RF OUT 1	8
RF OUT 2	5
CONTROL 1	3
CONTROL 2	1
GROUND	4,6,7

Outline Drawing

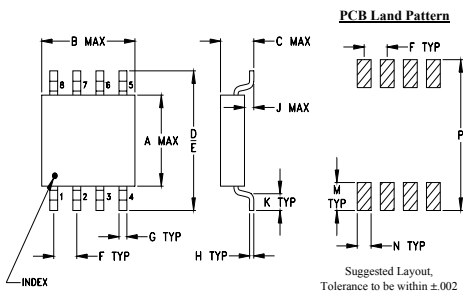

Outline Dimensions (inch/mm)

A	B	C	D	E	F	G
.163	.210	.077	.250	.220	.050	.017
4.14	5.33	1.96	6.35	5.59	1.27	0.43
H	J	K	M	N	P	wt
.009	.025	.030	.050	.030	.270	grams
0.23	0.64	0.76	1.27	0.76	6.86	0.10

Demo Board MCL P/N: TB-205 Suggested PCB Layout (PL-219)

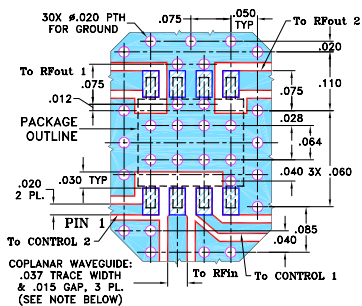

- NOTE:
- COPLANAR WAVEGUIDE PARAMETERS ARE SHOWN FOR ROGERS R04350B WITH DIELECTRIC THICKNESS .020" ± .0015"; COPPER: 1/2 OZ. EACH SIDE. FOR OTHER MATERIALS TRACE WIDTH & GAP MAY NEED TO BE MODIFIED.
 - BOTTOM SIDE OF THE PCB IS CONTINUOUS GROUND PLANE.
 - DIENOTES PCB COPPER LAYOUT WITH SMOBC (SOLDER MASK OVER BARE COPPER)
 - DIENOTES COPPER LAND PATTERN FREE OF SOLDER MASK

Features

- wideband, DC to 2.0 GHz
- low video leakage, 8 mVp-p typ.
- very fast switching, 5ns typ.

Applications

- cellular
- PCN
- 2-way radio
- receiver antenna switching

Electrical Specifications

FREQ. (GHz)	INSERTION LOSS (dB)				1dB COMPR. (dBm)				IN-OUT ISOLATION (dB)					
	DC-100 MHz	100-500 MHz	500-1000 MHz	1000-2000 MHz	DC-100 MHz	100-500 MHz	500-1000 MHz	1000-2000 MHz	DC-100 MHz	100-500 MHz	500-1000 MHz	1000-2000 MHz		
f _L f _U	Typ. Max.	Typ. Max.	Typ. Max.	Typ. Max.	Typ.	Typ.	Typ.	Typ.	Typ.	Min.	Typ.	Min.	Typ.	Min.
DC 2.0	0.65 0.9	0.9 1.2	0.95 1.3	1.20 1.5	20 24	27 29			60 50	45 37	40 32	30 25		

Additional Specifications

Control Voltage	-8/0 for compression spec, -8 to -5/0 for all other specs	
Control Current, mA	0.2 max to -8V, 0.02 max at 0 to -0.2V	
VSWR(:1)	DC-1GHz 1.2 typ.	1-2GHz 1.4 typ.
Rise/Fall time (10%-90%), ns	3 typ.	
Switching time, 50% of Control to	5.5 typ	
90% RF(Turn-on), ns	3 typ	
10% RF(Turn-off), ns		

CONTROL LOGIC

Control Ports		RF outputs	
1	2	1	2
0	-V	Off	On
-V	0	On	Off

** Video leakage or break through is defined as leakage of switching signal to RF output ports.

- RF Power Input (dBm), Max. DC-100MHz 100-500 MHz 500-2000MHz
 - Steady State Control 0/-8V 24 27 33
 - As a Modulator 12 17 23
- Control Current, 500µA (occurs at -9V to -12V typ.)
- All RF pins must be DC blocked or held at 0V DC.

Electrical Schematic

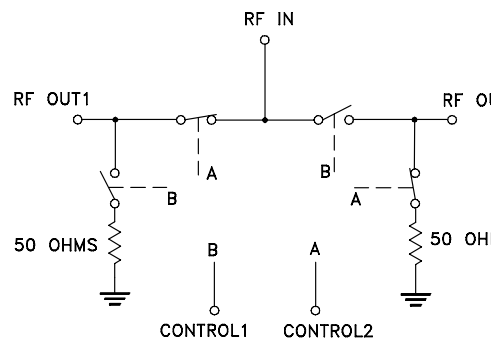

Mini-Circuits
ISO 9001 ISO 14001 AS 9100 CERTIFIED

For detailed performance specs & shopping online see web site

P.O. Box 350166, Brooklyn, New York 11235-0003 (718) 934-4500 Fax (718) 332-4661 The Design Engineers Search Engine Provides ACTUAL Data Instantly at minicircuits.com

Notes: 1. Performance and quality attributes and conditions not expressly stated in this specification sheet are intended to be excluded and do not form a part of this specification sheet. 2. Electrical specifications and performance data contained herein are based on Mini-Circuit's applicable established test performance criteria and measurement instructions. 3. The parts covered by this specification sheet are subject to Mini-Circuit's standard limited warranty and terms and conditions (collectively, "Standard Terms"); Purchasers of this part are entitled to the rights and benefits contained therein. For a full statement of the Standard Terms and the exclusive rights and remedies thereunder, please visit Mini-Circuit's website at www.minicircuits.com/MCLStore/terms.jsp.

Typical Performance Data

FREQ. (MHz)	INSERTION LOSS (dB) Control @ 0V/-5V IN-OUT		OFF ISOLATION (dB) Control @ 0V/-5V IN-OUT		VSWR		
	\bar{x}	σ	\bar{x}	σ	IN		OUT
					\bar{x}	σ	\bar{x}
10.00	0.64	0.01	78.59	1.40	1.14	1.14	1.01
17.47	0.64	0.02	76.90	1.20	1.14	1.14	1.01
39.90	0.66	0.02	70.66	0.59	1.14	1.14	1.02
62.32	0.68	0.02	64.78	0.25	1.13	1.13	1.02
77.27	0.70	0.02	62.02	0.20	1.13	1.13	1.02
114.65	0.73	0.06	57.36	0.20	1.12	1.12	1.02
219.30	0.82	0.06	51.14	0.20	1.10	1.10	1.03
421.12	0.92	0.02	46.47	0.22	1.08	1.08	1.06
525.77	0.96	0.02	45.07	0.25	1.08	1.08	1.08
735.07	0.99	0.01	42.82	0.27	1.08	1.10	1.12
832.25	0.99	0.03	41.86	0.28	1.09	1.11	1.14
996.70	1.04	0.02	40.17	0.29	1.12	1.14	1.17
1146.20	1.06	0.01	38.62	0.28	1.14	1.17	1.21
1348.02	1.08	0.04	36.61	0.26	1.17	1.22	1.26
1497.52	1.15	0.03	35.17	0.25	1.19	1.25	1.30
1759.15	1.18	0.03	32.75	0.23	1.23	1.31	1.38
1863.80	1.13	0.03	31.81	0.22	1.24	1.32	1.41
1968.45	1.18	0.02	30.98	0.22	1.26	1.34	1.44
1998.35	1.21	0.02	30.78	0.22	1.26	1.35	1.45
2073.10	1.23	0.70	30.18	0.22	1.28	1.36	1.48

