

Coaxial Bandpass Filter

NBP-1560+

50Ω 1500 to 1620 MHz

The Big Deal

- High rejection
- Fast roll-off
- Connectorized package



Generic photo used for illustration purposes only

CASE STYLE: FF779

Product Overview

NBP-1560+ is a band pass filter built in rugged connectorized package. Covering a pass band of 1500 to 1620 MHz, these units offer good matching within the pass band and high rejection. This will find its application in Transmitters / receivers and harmonic rejection. It has repeatable performance across production lots and consistent performance across temperature.

Key Features

Feature	Advantages
Narrow bandwidth filter	Fast roll-off, this will attenuate frequencies closer to the passband with good rejection value of >20dB
Sharp shape factor	Sharp shape factor helps in adjacent rejection and increased selectivity
Connectorized package	The connectorized packages are easy to interface with other devices and well suited for test set-ups.

Notes

- A. Performance and quality attributes and conditions not expressly stated in this specification document are intended to be excluded and do not form a part of this specification document.
B. Electrical specifications and performance data contained in this specification document are based on Mini-Circuit's applicable established test performance criteria and measurement instructions.
C. The parts covered by this specification document are subject to Mini-Circuits standard limited warranty and terms and conditions (collectively, "Standard Terms"); Purchasers of this part are entitled to the rights and benefits contained therein. For a full statement of the Standard Terms and the exclusive rights and remedies thereunder, please visit Mini-Circuits' website at www.minicircuits.com/MCLStore/terms.jsp



Coaxial Bandpass Filter

NBP-1560+

50Ω 1500 to 1620 MHz



Generic photo used for illustration purposes only

CASE STYLE: FF779

Connectors	Model
N-Type	NBP-1560+

Features

- High rejection
- Fast roll-off
- Temperature stable
- LTCC Construction
- Connectorized package

Applications

- Harmonic Rejection
- Transmitter / Receivers
- Lab use

Electrical Specifications at 25°C

Parameter	F#	Frequency (MHz)	Min.	Typ.	Max.	Unit	
Pass Band	Center Frequency	—	—	1560	—	MHz	
	Insertion Loss	F1-F2	1500 - 1620	—	2.7	4.5	dB
	VSWR	F1-F2	1500 - 1620	—	1.4	2.1	:1
Stop Band, Lower	Insertion Loss	DC-F3	DC -1060	20	32	—	dB
	VSWR	DC-F3	DC -1060	—	28	—	:1
Stop Band, Upper	Insertion Loss	F4-F5	2150 - 4200	20	28	—	dB
	VSWR	F4-F5	2150 - 4200	—	8	—	:1

Maximum Ratings

Operating Temperature	-40°C to 85°C
Storage Temperature	-55°C to 100°C
RF Power Input	1.5W max.

Permanent damage may occur if any of these limits are exceeded.

Functional Schematic

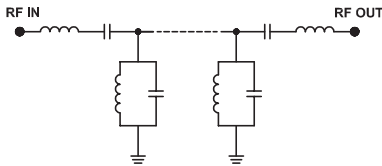

Typical Frequency Response

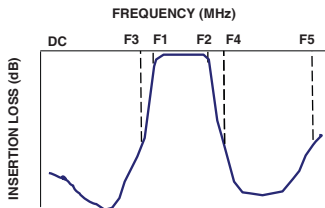

Typical Performance Data at 25°C

Frequency (MHz)	Insertion Loss (dB)	VSWR (:1)	Frequency (MHz)	Group Delay (nsec)
1	103.25	347.44	1500	1.91
50	83.60	173.72	1510	1.88
500	46.86	62.05	1520	1.85
1000	38.12	32.79	1530	1.83
1060	32.05	28.03	1535	1.82
1100	28.46	24.48	1540	1.82
1260	14.84	10.37	1545	1.81
1350	7.21	3.75	1550	1.81
1410	3.83	1.58	1555	1.81
1500	2.62	1.31	1560	1.80
1560	2.52	1.39	1570	1.80
1620	2.62	1.42	1580	1.81
1740	3.38	1.46	1585	1.81
1830	6.45	2.13	1590	1.82
1890	12.57	4.12	1595	1.82
1980	24.13	6.15	1600	1.82
2150	37.55	9.43	1605	1.82
3000	28.89	39.49	1610	1.83
3500	27.87	32.79	1615	1.83
4200	31.69	32.79	1620	1.83

+RoHS Compliant

The +Suffix identifies RoHS Compliance. See our web site for RoHS Compliance methodologies and qualifications

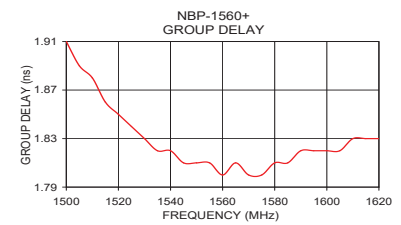
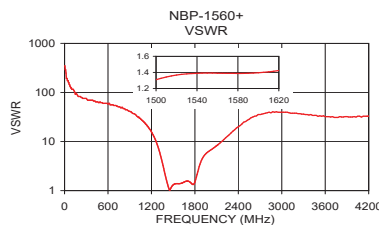
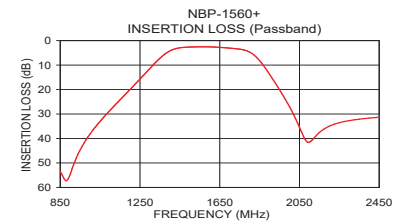
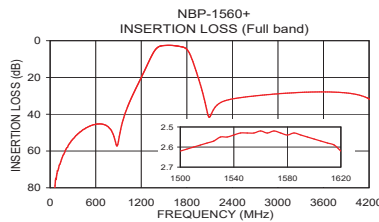

Notes

- Performance and quality attributes and conditions not expressly stated in this specification document are intended to be excluded and do not form a part of this specification document.
- Electrical specifications and performance data contained in this specification document are based on Mini-Circuits' applicable established test performance criteria and measurement instructions.
- The parts covered by this specification document are subject to Mini-Circuits standard limited warranty and terms and conditions (collectively, "Standard Terms"); Purchasers of this part are entitled to the rights and benefits contained therein. For a full statement of the Standard Terms and the exclusive rights and remedies thereunder, please visit Mini-Circuits' website at www.minicircuits.com/MCLStore/terms.jsp



www.minicircuits.com P.O. Box 350166, Brooklyn, NY 11235-0003 (718) 934-4500 sales@minicircuits.com

REV.B
ECO-004610
NBP-1560+
EDU1450
URJ
201017
Page 2 of 3

Coaxial Connections

INPUT	N Female
OUTPUT	N Male

Outline Drawing

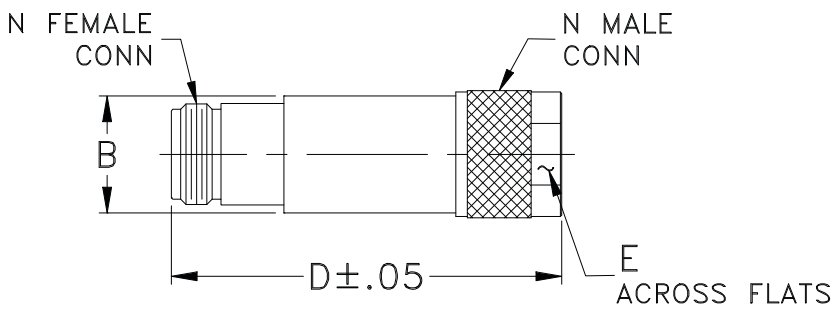

Outline Dimensions ($\frac{\text{inch}}$ / mm)

A	B	C	D	E	Wt.
--	.71	--	2.11	.718	grams
--	18.03	--	53.59	18.24	72.5

Note: Please refer to case style drawing for details

Notes

- A. Performance and quality attributes and conditions not expressly stated in this specification document are intended to be excluded and do not form a part of this specification document.
- B. Electrical specifications and performance data contained in this specification document are based on Mini-Circuit's applicable established test performance criteria and measurement instructions.
- C. The parts covered by this specification document are subject to Mini-Circuits standard limited warranty and terms and conditions (collectively, "Standard Terms"); Purchasers of this part are entitled to the rights and benefits contained therein. For a full statement of the Standard Terms and the exclusive rights and remedies thereunder, please visit Mini-Circuits' website at www.minicircuits.com/MCLStore/terms.jsp

