



MMIC SURFACE MOUNT

# Low Noise Amplifier

## PMA3-10203+

50Ω 12.5 to 20 GHz Shutdown Feature

### THE BIG DEAL

- Low Noise Figure, Typ. 1.5 dB
- High OIP3, Typ. +24 dBm
- High P1dB, Typ. +16 dBm
- Shutdown Feature
- Single +5 V Supply Voltage
- 3x3 mm, 16-Lead QFN-Style Package

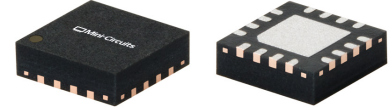

Generic photo used for illustration purposes only

### APPLICATIONS

- Test & Measurement Equipment
- Back Haul Radio Systems
- Satellite Communications
- Radar, EW, and ECM Defense Systems

### FUNCTIONAL DIAGRAM

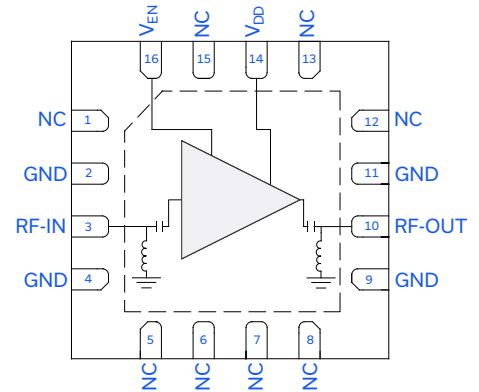

### PRODUCT OVERVIEW

The PMA3-10203+ is a pHEMT-based wideband, ultra-low noise MMIC amplifier with high IP3, flat gain, and voltage-controlled shutdown capability. Operating from 12.5 to 20 GHz, this amplifier features high dynamic range with typical 1.5 dB noise figure, 21 dB gain, +16 dBm P1dB, and +24 dBm OIP3. This combination of characteristics makes it ideal for sensitive, high dynamic range receiver applications. The device is internally DC blocked, and a DC path to ground is present at the RF input and output ports for ESD protection. PMA3-10203+ operates on a single +5 V supply, is well matched to 50Ω, and comes in a small, low profile 3x3 mm QFN-style package for easy integration into dense circuit board layouts.

### KEY FEATURES

Features	Advantages
Low Noise Figure, Typ. 1.5 dB	This ultra-low noise MMIC device enables low system noise figure performance without the need for complicated discrete-based solutions.
High Dynamic Range <ul style="list-style-type: none"> <li>• Gain, Typ. 21 dB</li> <li>• OIP3, Typ. +24 dBm</li> <li>• P1dB, Typ. +16 dBm</li> </ul>	The MMIC amplifier's unique combination of low noise figure, high gain, high P1dB, and high OIP3 enables optimum performance in sensitive high dynamic range receivers.
Shutdown Feature	A shutdown feature allows the part to be quickly disabled to conserve power when not in use.
3x3mm 16-Lead QFN-Style Package	Small footprint saves space in dense layouts while providing low inductance, repeatable transitions, and excellent thermal contact to the PCB. Industry-standard packaging allows for ease of assembly in high-volume manufacturing processes.





MMIC SURFACE MOUNT

## Low Noise Amplifier

PMA3-10203+

Mini-Circuits

50Ω 12.5 to 20 GHz Shutdown Feature

ELECTRICAL SPECIFICATIONS<sup>1</sup> AT +25°C, V<sub>DD</sub> = +5 V, V<sub>EN</sub> = +5 V UNLESS NOTED OTHERWISE

Parameter	Condition (GHz)	Min.	Typ.	Max.	Units
Frequency Range		12.5		20	GHz
Gain	12.5	17.5	20.8		dB
	14	18.0	21.3		
	16	19.2	22.2		
	18	17.8	20.7		
	20	15.5	18.8		
Input Return Loss	12.5		13		dB
	14		9		
	16		8		
	18		8		
	20		9		
Output Return Loss	12.5		19		dB
	14		15		
	16		12		
	18		20		
	20		15		
Isolation	12.5 - 20		48		dB
Output Power at 1 dB Compression (P <sub>1dB</sub> )	12.5		+15.2		dBm
	14		+16.0		
	16		+16.1		
	18		+16.4		
	20		+15.7		
Output Third-Order Intercept (P <sub>OUT</sub> = +5 dBm/Tone)	12.5		+23		dBm
	14		+25		
	16		+25		
	18		+24		
	20		+23		
Noise Figure	12.5		1.4		dB
	14		1.3		
	16		1.4		
	18		1.5		
	20		2.1		
FALL Time (90% RF to 10% RF) <sup>2</sup>			13		ns
RISE Time (10% RF to 90% RF) <sup>2</sup>			108		ns
Device Operating Voltage (V <sub>DD</sub> )		+4.75	+5	+5.25	V
Device Operating Current (I <sub>DD</sub> ) <sup>3</sup>			56		mA
Enable Voltage (V <sub>EN</sub> ) <sup>4</sup>		+4.75	+5	+5.25	V
Enable Current (I <sub>EN</sub> ) at V <sub>EN</sub> = +5 V			0.86		mA
DC Current Variation vs. Temperature <sup>5</sup>			-86.7		μA/°C
DC Current Variation vs. Voltage <sup>6</sup>			0.004		mA/mV

1. Tested on Mini-Circuits Characterization Test Board TB-PMA3-10203C+. See Figure 2. Board loss de-embedded to the device.

2. Measured with bypass capacitors C2 and C4 removed from TB-PMA3-10203C+.

3. Current at P<sub>N</sub> = -25 dBm. Increases to 61 mA at P<sub>1dB</sub>.4. V<sub>EN</sub> ≤ V<sub>DD</sub> under nominal operating conditions.

5. (Current at +105°C - Current at -45°C) / (+150°C)

6. (Current at +5.25 V - Current at +4.75 V) / (+5.25 V - +4.75 V)





### TYPICAL PERFORMANCE GRAPHS

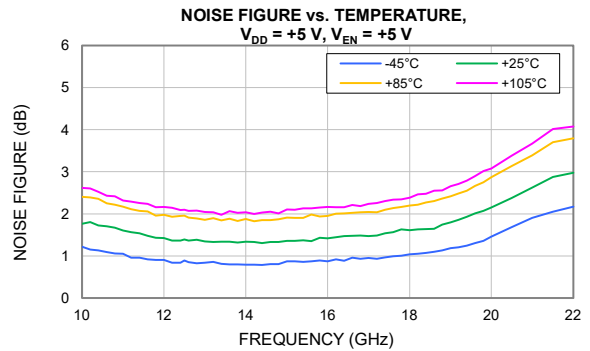
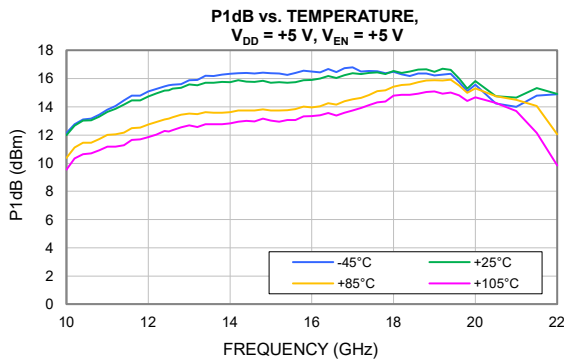
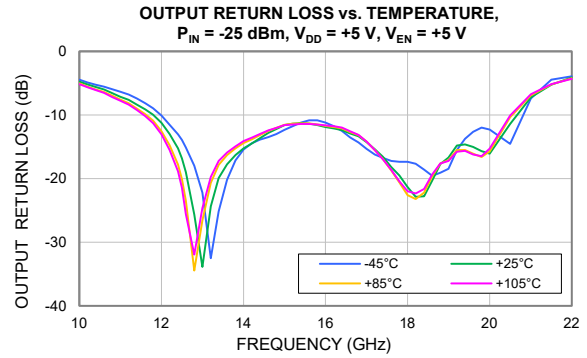
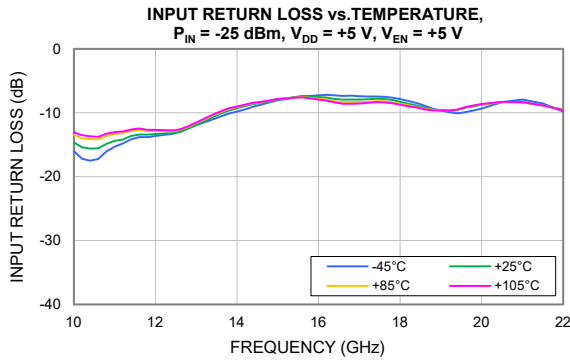
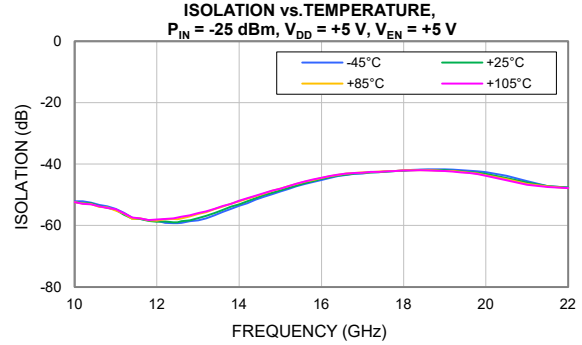
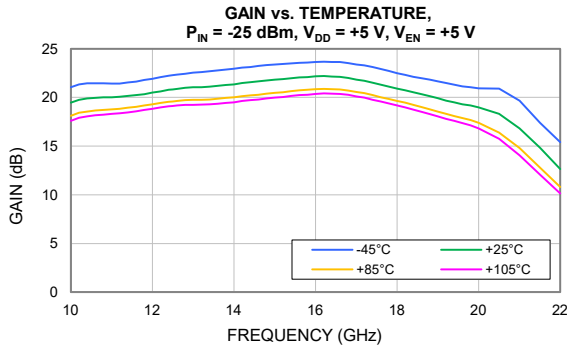



### TYPICAL PERFORMANCE GRAPHS

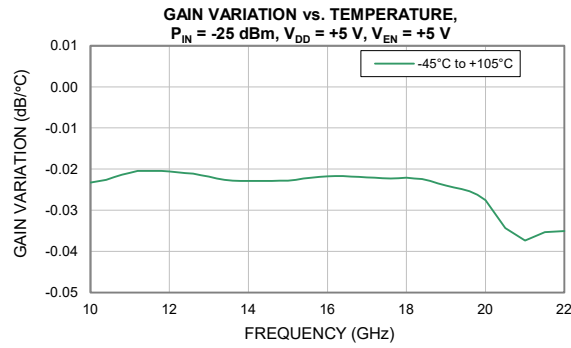
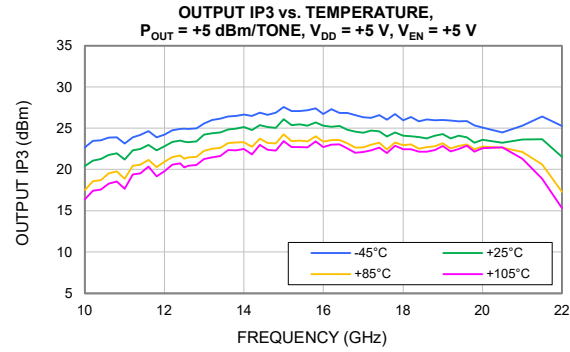
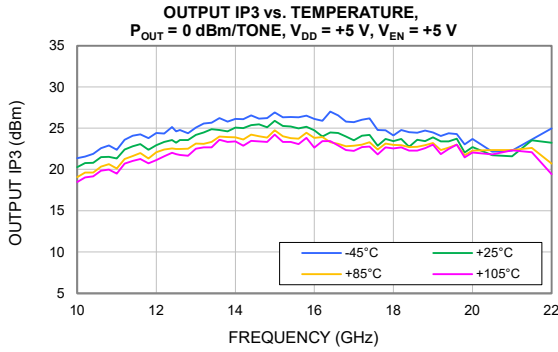



MMIC SURFACE MOUNT

# Low Noise Amplifier

# PMA3-10203+

Mini-Circuits

50Ω 12.5 to 20 GHz Shutdown Feature

## ABSOLUTE MAXIMUM RATINGS<sup>7</sup>

Parameter	Ratings
Operating Temperature	-45°C to +105°C
Storage Temperature	-65°C to +150°C
Junction Temperature <sup>8</sup>	+150°C
Total Power Dissipation	0.7 W
Input Power (CW), V <sub>DD</sub> = +5 V	+19 dBm
DC Voltage at V <sub>DD</sub>	+7 V
Current I <sub>DD</sub>	100 mA
DC Voltage at V <sub>EN</sub>	+7 V

7. Permanent damage may occur if any of these limits are exceeded. Maximum ratings are not intended for continuous normal operation.

8. Peak temperature on top of Die.

## ENABLE VOLTAGE (V<sub>EN</sub>)

	Min.	Typ.	Max.	Units
Amplifier-ON	+4.75	+5.0	+5.25	V
Amplifier-OFF	0	-	+1.5	V

## THERMAL RESISTANCE

Parameter	Ratings
Thermal Resistance (Θ <sub>JC</sub> ) <sup>9</sup>	61.1°C/W

9. Θ<sub>JC</sub> = (Hot Spot Temperature on Die - Temperature at Ground Lead)/Dissipated Power

## ESD RATING

	Class	Voltage Range	Reference Standard
HBM	1C	1000 V to < 2000 V	ANSI/ESDA/JEDEC JS-001-2017
CDM	C3	≥1000 V	JESD22-C101F



ESD HANDLING PRECAUTION: This device is designed to be Class 1C for HBM. Static charges may easily produce potentials higher than this with improper handling and can discharge into DUT and damage it. As a preventive measure Industry standard ESD handling precautions should be used at all times to protect the device from ESD damage.

## MSL RATING

Moisture Sensitivity: MSL1 in accordance with IPC/JEDEC J-STD-020E /JEDEC J-STD-033C





### FUNCTIONAL DIAGRAM

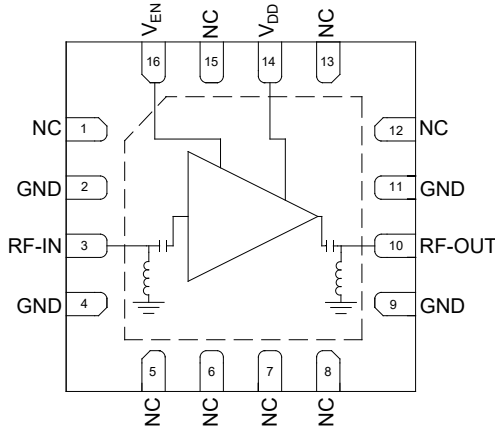

Figure 1. PMA3-10203+ Functional Diagram

### PAD DESCRIPTION

Function	Pad Number	Description (Refer to Figure 2)
RF-IN	3	RF-IN Pad connects to RF Input port.
RF-OUT	10	RF-OUT Pad connects to RF Output port.
V <sub>DD</sub>	14	DC Input Pad connects to voltage input port V <sub>DD</sub> .
V <sub>EN</sub>	16	DC Input Pad connects to enable voltage input port V <sub>EN</sub> .
GND	2, 4, 9, 11 & Paddle	Connects to ground.
NC	1, 5-8, 12, 13, 15	Not used internally. Connected to ground on test board.

### CHARACTERIZATION TEST BOARD

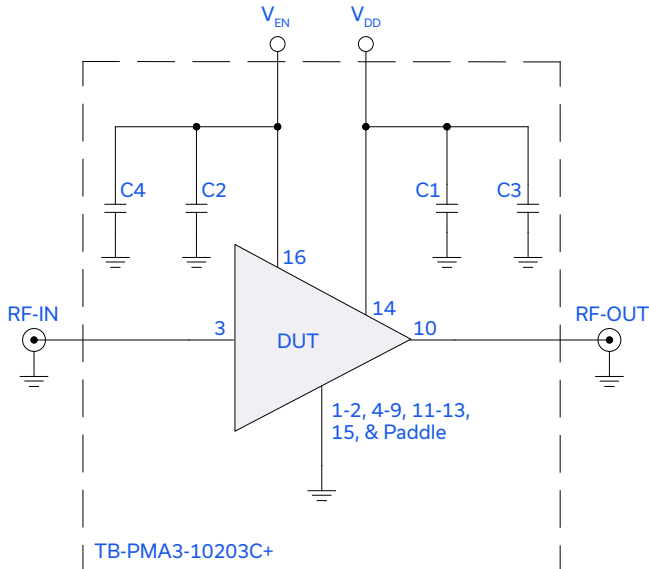

Figure 2. PMA3-10203+ Characterization and Application Circuit.

#### Electrical Parameters and Conditions

Gain, Return Loss, Output Power at 1dB Compression (P1dB), Output IP3 (OIP3), and Noise Figure measured using N5242A PNA-X Microwave Network Analyzer. For Switching Speed measurements, bypass capacitors C2 and C4 were removed from TB-PMA3-10203C+.

#### Conditions:

- Gain and Return Loss: P<sub>IN</sub> = -25 dBm
- Output IP3 (OIP3): Two tones, spaced 1 MHz apart, +5 dBm/Tone at output.
- V<sub>DD</sub> = +5 V

Component	Vendor	Vendor P/N	Value	Size
C1, C2	Murata	GRM1555C1H101JA01D	100 pF	0402
C3, C4	Murata	GRM155R71H104KE14J	0.1 μF	0402

#### Power ON/Power OFF Sequence:

Parts are not sensitive to power ON/OFF sequence. V<sub>DD</sub> and V<sub>EN</sub> can be applied in any order.



### CASE STYLE DRAWING

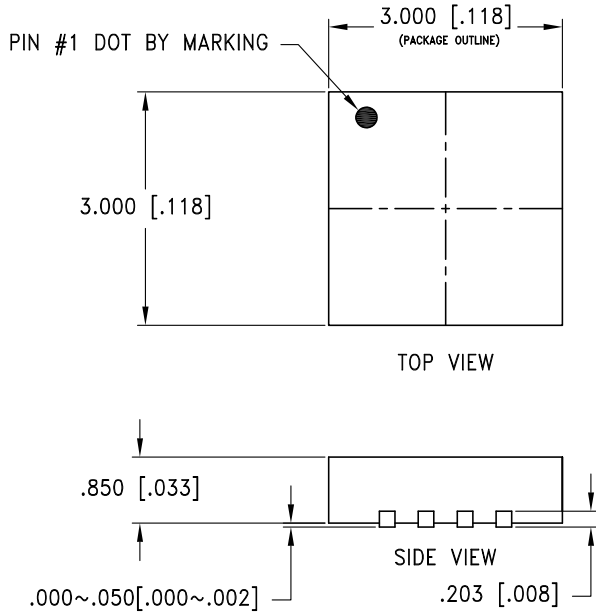

### PCB Land Pattern

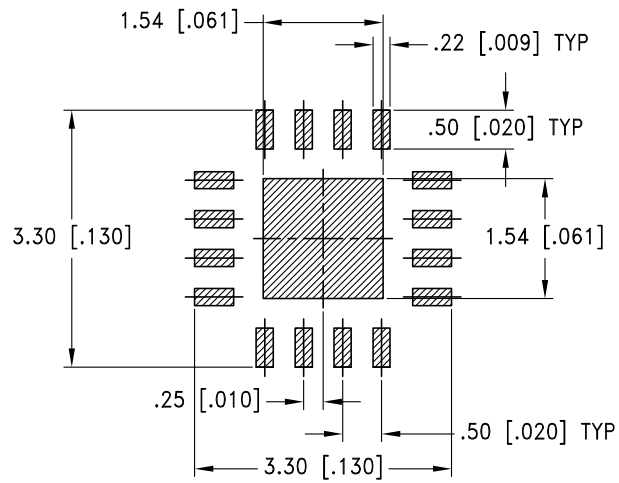

### Suggested Layout

Tolerances to be within  $\pm 0.05 [0.002]$

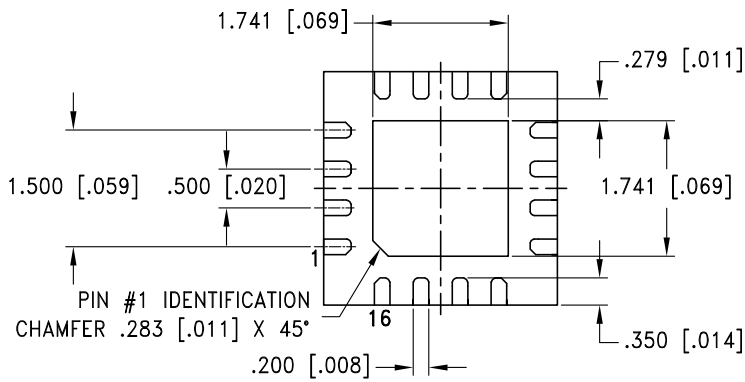

Weight: .02 grams

Dimensions are in mm [Inches]. Tolerances: 3 Pl.  $\pm 0.05 [0.002]$

### PRODUCT MARKING

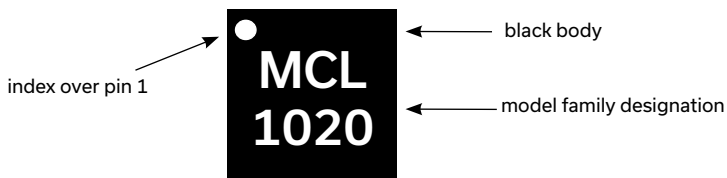

Marking may contain other features or characters for internal lot control



MMIC SURFACE MOUNT

# Low Noise Amplifier

## PMA3-10203+

Mini-Circuits

50Ω 12.5 to 20 GHz Shutdown Feature

ADDITIONAL DETAILED INFORMATION IS AVAILABLE ON OUR DASH BOARD [CLICK HERE](#)

<b>Performance Data</b>	Data Graphs S-Parameter (S2P Files) Data Set (.zip file)
<b>Case Style</b>	DQ3005. Plastic package, exposed paddle, lead finish: Matte-Tin
<b>RoHS Status</b>	Compliant
<b>Tape &amp; Reel</b> Standard quantities available on reel	F104 7" reels with 20, 50, 100, 200, 500, 1000, or 2000 devices
<b>Suggested Layout for PCB Design</b>	PL-784
<b>Evaluation Board</b>	TB-PMA3-10203C+ Gerber File
<b>Environmental Ratings</b>	ENV08T1

### NOTES

- A. Performance and quality attributes and conditions not expressly stated in this specification document are intended to be excluded and do not form a part of this specification document.
- B. Electrical specifications and performance data contained in this specification document are based on Mini-Circuit's applicable established test performance criteria and measurement instructions.
- C. The parts covered by this specification document are subject to Mini-Circuits standard limited warranty and terms and conditions (collectively, "Standard Terms"); Purchasers of this part are entitled to the rights and benefits contained therein. For a full statement of the standard terms and the exclusive rights and remedies thereunder, please visit Mini-Circuits' website at [www.minicircuits.com/terms/viewterm.html](http://www.minicircuits.com/terms/viewterm.html)

