

USB Smart Power Sensor

PWR-8GHS+

50Ω -30 dBm to +20 dBm, 1 MHz to 8000 MHz

The Big Deal

- Low cost
- USB HID device compatible with 32/64 Bit operating systems
- Includes “Measurement Application” GUI (Graphical User Interface) software with an API-DLL com object
- High speed measurement capability



Installation CD with Software included

CASE STYLE: JL1504

Product Overview

The Mini-Circuits PWR-8GHS+ Smart Power Sensor is a pocket-sized, 4.89” x 1.74” x 0.95”, precision test USB HID device (no driver installation required) that turns a Windows® or Linux® PC into a power meter. Each unit is shipped with our N-to-SMA adapter and a quick-locking USB cable for reliable connectivity. Native software and detailed user guides are provided on the included CD, or can be downloaded from minicircuits.com anywhere an internet connection is available, providing a full range of data analysis options.

Key Features

Feature	Advantages
USB HID (Human Interface Device)	Plug-and-Play (no need to install driver for the device).
GUI Measurement Application Software built-in	Enables the user to perform measurements on RF components such as Couplers, Filters, Amplifiers etc. and displays numerical data and graphs .
32/64 Bit operating systems	Compatible with Windows® and Linux® operating systems.
No calibration required before taking measurement	The PWR-8GHS+ does not require any reference signal for calibration.



For detailed performance specs & shopping online see web site

P.O. Box 350166, Brooklyn, New York 11235-0003 (718) 934-4500 Fax (718) 332-4661 The Design Engineers Search Engine  Provides ACTUAL Data Instantly at minicircuits.com

IF/RF MICROWAVE COMPONENTS

Notes: 1. Performance and quality attributes and conditions not expressly stated in this specification sheet are intended to be excluded and do not form a part of this specification sheet. 2. Electrical specifications and performance data contained herein are based on Mini-Circuit's applicable established test performance criteria and measurement instructions. 3. The parts covered by this specification sheet are subject to Mini-Circuits standard limited warranty and terms and conditions (collectively, "Standard Terms"); Purchasers of this part are entitled to the rights and benefits contained therein. For a full statement of the Standard Terms and the exclusive rights and remedies thereunder, please visit Mini-Circuits' website at www.minicircuits.com/MCLStore/terms.jsp.

Wide Dynamic Range

USB Smart Power Sensor

50Ω 1 MHz to 8000 MHz

Product Features

- Wide bandwidth, 1 to 8000 MHz
- 50 dB Dynamic Range, -30 to +20 dBm
- Good VSWR, 1.1:1 typ.
- Fast measurement speed, 30 msec typ.
- Automatic frequency calibration & temperature compensation
- Multi-sensor capability (up to 24)
- Built in Application Measurement Software
- Remote operation via internet
- Effective, easy-to-use Windows® GUI
- Linux® support
- DLL com object for use with other testing software: LabVIEW®, Delphi®, C++, C#, Visual Basic®, and .Net¹



Installation CD with Software included

PWR-8GHS+

Order P/N	Description	Price	Qty.
PWR-8GHS+	USB Smart Power Sensor plus accessories	\$869.00 ea.	(1-4)
PWR-SEN-8GHS+	Power Sensor Head		
USB-CBL+	Data Cable (USB Type-A plug)		
NM-SM50+	N-Type (F) to SMA (M) Adapter		
PWR-SEN-CD	Installation CD		

Typical Applications

- Turn almost any Windows or Linux PC into a Power Meter
- Pocket-sized portability for benchtop testing anywhere
- Remote location monitoring
- Automatic, scheduled data collection
- Evaluate high-power, multi-port devices with built-in virtual couplers/attenuators & other software tools

+ RoHS compliant in accordance with EU Directive (2002/95/EC)

The +Suffix has been added in order to identify RoHS Compliance. See our web site for RoHS Compliance methodologies and qualifications.

Mini-Circuits Power Meter Program for Smart USB Power Sensor

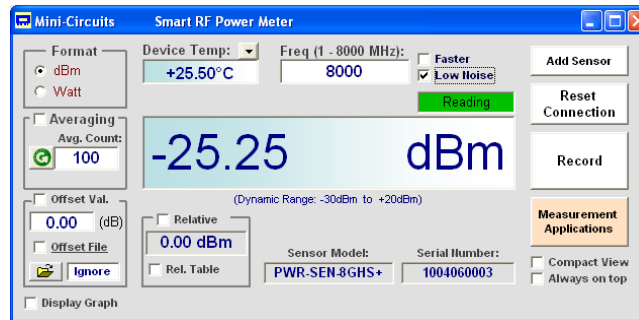

Note 1: Windows and Visual Basic are registered trademarks of Microsoft Corporation. Linux is a registered trademark of Linus Torvalds. LabVIEW is a registered trademark of National Instruments Corp. Delphi is a registered trademark of Codegear LLC. Neither Mini-Circuits nor the Mini-Circuits PWR-8GHS+ smart Power Sensor are affiliated with or endorsed by the owners of the above referenced trademarks.

Mini-Circuits and the Mini-Circuits logo are registered trademarks of Scientific Components Corporation.



For detailed performance specs & shopping online see web site

REV. C
M131329
EDR-10190
PWR-8GHS+
RAV
110531
Page 2 of 5

P.O. Box 350166, Brooklyn, New York 11235-0003 (718) 934-4500 Fax (718) 332-4661 The Design Engineers Search Engine Provides ACTUAL Data Instantly at minicircuits.com

Notes: 1. Performance and quality attributes and conditions not expressly stated in this specification sheet are intended to be excluded and do not form a part of this specification sheet. 2. Electrical specifications and performance data contained herein are based on Mini-Circuit's applicable established test performance criteria and measurement instructions. 3. The parts covered by this specification sheet are subject to Mini-Circuits standard limited warranty and terms and conditions (collectively, "Standard Terms"); Purchasers of this part are entitled to the rights and benefits contained therein. For a full statement of the Standard Terms and the exclusive rights and remedies thereunder, please visit Mini-Circuits' website at www.minicircuits.com/MCLStore/terms.jsp.

Electrical Specifications, -30 dBm to +20 dBm, 1 to 8000 MHz

Parameter	Freq. Range (MHz)	Min.	Typ.	Max.	Units	
Dynamic Range	1 - 8000	-30	-	+20	dBm	
VSWR	1 - 8000	-	1.1	1.3	:1	
Uncertainty of Power Measurement @ 25°C	@ -30 to +5 dBm	1 - 3000	-	± 0.10	± 0.30	dB
		3000 - 8000	-	± 0.15	± 0.40	dB
	@ +5 to +15 dBm	1 - 3000	-	± 0.15	± 0.30	dB
		3000 - 8000	-	± 0.15	± 0.40	dB
	@ +15 to +20 dBm	1 - 3000	-	± 0.15	± 0.40	dB
		3000 - 8000	-	± 0.20	± 0.45	dB
Uncertainty of Power Measurement @ 0°C to 50°C	@ -30 to +5 dBm	1 - 3000	-	± 0.20	-	dB
		3000 - 8000	-	± 0.20	-	dB
	@ +5 to +15 dBm	1 - 3000	-	± 0.20	-	dB
		3000 - 8000	-	± 0.20	-	dB
	@ +15 to +20 dBm	1 - 3000	-	± 0.20	-	dB
		3000 - 8000	-	± 0.20	-	dB
Linearity @ 25°C	1 - 8000	-	± 3.0	-	%	
Measurement Resolution	1 - 8000	0.01	-	-	dB	
Averaging Range	1 - 8000	1	-	999	-	
Measurement Speed	@ Low Noise Mode	1 - 8000	-	100	-	mSec
	@ Faster Mode		-	30	-	
Current (via host USB)	1 - 8000	-	40	70	mA	

Minimum System Requirements

Parameter	Requirements
Interface	USB HID
Host operating system	32 Bit operating system: Windows 98®, Windows XP®, Windows Vista®, Windows 7® 64 Bit operating system: Windows Vista®, Windows 7® Linux® support: 32/64 Bit operating system
Hardware	Pentium® II or higher, RAM 256 Mb, USB port
USB cable (supplied)	To be used with the supplied USB cable only

Absolute Maximum Ratings

Parameter	Ratings
Operating Temperature	0°C to 50°C
Storage Temperature	-30°C to 70°C
DC Voltage at RF port	15V
CW Power	+27 dBm

Permanent damage may occur if any of these limits are exceeded.



For detailed performance specs & shopping online see web site

P.O. Box 350166, Brooklyn, New York 11235-0003 (718) 934-4500 Fax (718) 332-4661 The Design Engineers Search Engine  Provides ACTUAL Data Instantly at minicircuits.com

IF/RF MICROWAVE COMPONENTS

Notes: 1. Performance and quality attributes and conditions not expressly stated in this specification sheet are intended to be excluded and do not form a part of this specification sheet. 2. Electrical specifications and performance data contained herein are based on Mini-Circuit's applicable established test performance criteria and measurement instructions. 3. The parts covered by this specification sheet are subject to Mini-Circuits standard limited warranty and terms and conditions (collectively, "Standard Terms"); Purchasers of this part are entitled to the rights and benefits contained therein. For a full statement of the Standard Terms and the exclusive rights and remedies thereunder, please visit Mini-Circuits' website at www.minicircuits.com/MCLStore/terms.jsp. Page 3 of 5

Typical Performance Curves

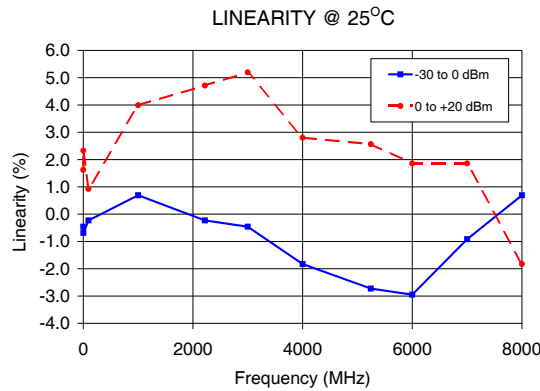
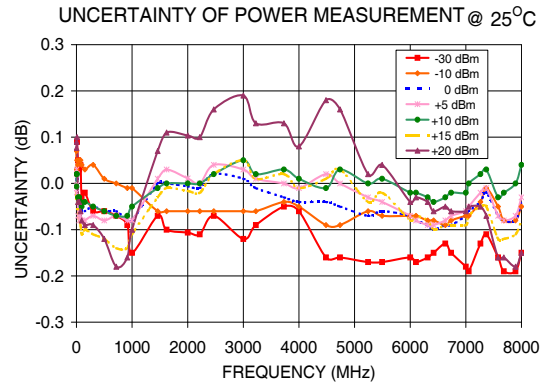
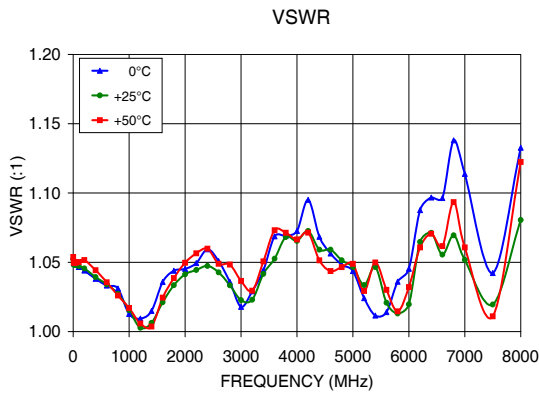

Outline Drawing (JL1504)

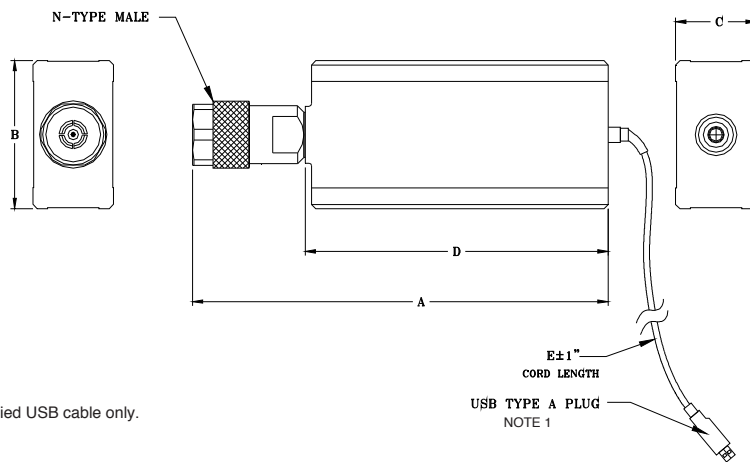

NOTE 1: To be used with the supplied USB cable only.

Outline Dimensions (inch/mm)

A	B	C	D	E	WT. GRAMS
4.89	1.74	.95	3.50	72.0	250
124.2	44.2	24.1	88.9	1829	



For detailed performance specs & shopping online see web site

P.O. Box 350166, Brooklyn, New York 11235-0003 (718) 934-4500 Fax (718) 332-4661 The Design Engineers Search Engine Provides ACTUAL Data Instantly at minicircuits.com

IF/RF MICROWAVE COMPONENTS

Notes: 1. Performance and quality attributes and conditions not expressly stated in this specification sheet are intended to be excluded and do not form a part of this specification sheet. 2. Electrical specifications and performance data contained herein are based on Mini-Circuit's applicable established test performance criteria and measurement instructions. 3. The parts covered by this specification sheet are subject to Mini-Circuits standard limited warranty and terms and conditions (collectively, "Standard Terms"); Purchasers of this part are entitled to the rights and benefits contained therein. For a full statement of the Standard Terms and the exclusive rights and remedies thereunder, please visit Mini-Circuits' website at www.minicircuits.com/MCLStore/terms.jsp. Page 4 of 5

Warranty

For a full statement of the limited warranty offered by Mini-Circuits for the PWR-8GHS+ and the non-exclusive license for the software provided with the PWR-8GHS+ and the exclusive rights and remedies thereunder, together with Mini-Circuit's limitations of warranties and limitation of liability, please refer to Mini-Circuits User Guide for the PWR-8GHS+ and Mini-Circuits standard terms of sale found on its standard purchase order acknowledgment form, which are incorporated herein by reference. If you do not have these documents, please contact a Mini-Circuits representative and these documents will be provided promptly. Alternatively, for a copy of Mini-Circuits' standard terms of sale, visit Mini-Circuits' website at www.minicircuits.com/MCLStore/terms.jsp.

THE SOFTWARE IS PROVIDED "AS IS", "WITH ALL FAULTS", AND WITHOUT ANY EXPRESS OR IMPLIED WARRANTY OF ANY KIND, ALL OF WHICH ARE HEREBY WAIVED.

Ordering Information

Model Number	Description	Quantity Min. No. of Units	Price \$ Ea.
PWR-8GHS+	USB Smart Power Sensor with USB cable, NF-SM Adapter & Installation CD	1-4	869.00
PWR-SEN-8GHS+	Power Sensor Head	1	Included
USB-CBL+ <small>NOTE 1</small>	Data cable with USB Type-A plug connector	1	
NF-SM50+	N-Type Female to SMA-Male Adapter	1	
PWR-SEN-CD	Installation CD	1	
CALSEN-8GHS	Annual Calibration	1	99.00

NOTE 1: To be used with the supplied USB cable only.