

Surface Mount Diplexer

RDP-2150+

50Ω DC to 2150 MHz
(DC-10, 40-2150 MHz)



CASE STYLE: CK605

The Big Deal

- Low insertion loss
- Extended stopband rejection
- Miniature shielded package

Product Overview

RDP-2150+ is a low-pass + high-pass combination device. Low pass port is designed for DC to 10 MHz and high pass port is designed for 40 to 2150 MHz. This diplexer can be used in satellite, CATV, set-top box, modem, video equipment and other multiband radio systems.

Key Features

Feature	Advantages
Low passband insertion loss	Suitable for high performance application.
Extended stopband rejection	Spurious rejection and avoids using additional filters.
Miniature shielded package.	Reduced interference with the surrounding components.

Notes

- A. Performance and quality attributes and conditions not expressly stated in this specification document are intended to be excluded and do not form a part of this specification document.
B. Electrical specifications and performance data contained in this specification document are based on Mini-Circuit's applicable established test performance criteria and measurement instructions.
C. The parts covered by this specification document are subject to Mini-Circuits standard limited warranty and terms and conditions (collectively, "Standard Terms"); Purchasers of this part are entitled to the rights and benefits contained therein. For a full statement of the Standard Terms and the exclusive rights and remedies thereunder, please visit Mini-Circuits' website at www.minicircuits.com/MCLStore/terms.jsp

Surface Mount Diplexer

RDP-2150+

50Ω DC to 2150 MHz (DC-10, 40-2150 MHz)

Maximum Ratings

Operating Temperature	-40°C to 85°C
Storage Temperature	-55°C to 100°C
Max. DC Voltage	25V
Max. Input Current	100 mA
Max. RF Power Input	350mW

1. Exceeding any one or combination of these limits may cause permanent damage.
2. Sustained operation near these survivability limits is not recommended.

Pin Connections

HIGH PASS PORT	14
LOW PASS PORT	10
COMMON PORT	2
GROUND	1,3-9,11-13,15,16

Outline Drawing

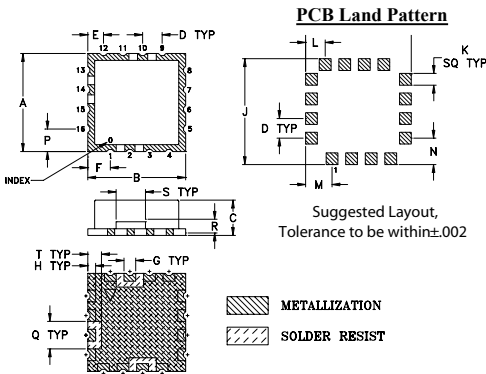

Outline Dimensions (inch/mm)

A	B	C	D	E	F	G	H	J	K
.500	.500	.180	.100	.080	.115	.060	.040	.540	.060
12.7	12.7	4.572	2.54	2.032	2.921	1.524	1.016	13.72	1.524
L	M	N	P	Q	R	S	T	Wt.	
.100	.135	.135	.115	.140	.070	.150	.070	grams	
2.54	3.429	3.429	2.921	3.556	1.778	3.81	1.778	1.0	

Demo Board MCL P/N: TB-10 Suggested PCB Layout (PL-012)

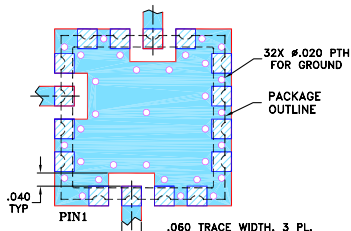

NOTES: 1. TRACE WIDTH IS SHOWN FOR FR4 WITH DIELECTRIC THICKNESS .030" ± .002"; COPPER: 1/2 OZ. EACH SIDE. FOR OTHER MATERIALS TRACE WIDTH MAY NEED TO BE MODIFIED.
2. BOTTOM SIDE OF THE PCB IS CONTINUOUS GROUND PLANE.

- Blue hatched area DENOTES PCB COPPER LAYOUT WITH SMOBC (SOLDER MASK OVER BARE COPPER)
- White hatched area DENOTES COPPER LAND PATTERN FREE OF SOLDER MASK

Notes

A. Performance and quality attributes and conditions not expressly stated in this specification document are intended to be excluded and do not form a part of this specification document.
B. Electrical specifications and performance data contained in this specification document are based on Mini-Circuits' applicable established test performance criteria and measurement instructions.
C. The parts covered by this specification document are subject to Mini-Circuits' standard limited warranty and terms and conditions (collectively, "Standard Terms"); Purchasers of this part are entitled to the rights and benefits contained therein. For a full statement of the Standard Terms and the exclusive rights and remedies thereunder, please visit Mini-Circuits' website at www.minicircuits.com/MCLStore/terms.jsp

Features

- Low insertion loss
- 50Ω Impedance
- Combination of Low pass and High pass filters
- Miniature shielded package
- Aqueous washable

Applications

- Set-top box
- Satellite
- CATV
- Multiband radio systems



CASE STYLE: CK605

+RoHS Compliant

The +Suffix identifies RoHS Compliance. See our web site for RoHS Compliance methodologies and qualifications

Electrical Specifications at 25°C

Parameter	Port	Frequency (MHz)	Min.	Typ.	Max.	Unit	
Pass Band	Insertion Loss	Low Pass	DC-10	-	0.5	1.0	dB
		High Pass	40-2150	-	0.9	1.5	
	Return Loss	Low Pass	DC-10	16	29	-	dB
		High Pass	40-2150	12	16	-	
Common		DC-10	16	23	-		
Stop Band Isolation	Low Pass	40-2200	20	31	-	dB	
		50-2150	30	44	-		
	High Pass	DC-18	20	33	-	dB	
		DC-10	30	61	-		

Typical Performance Data at 25°C

FREQUENCY (MHz)	INSERTION LOSS (dB)			RETURN LOSS (dB)	
	Low Pass Port	High Pass Port	Common Port	Low Pass Port	High Pass Port
1	0.36	100.14	29.01	29.46	0.05
10	0.49	61.27	24.22	35.22	0.16
18	0.82	33.52	24.77	24.20	0.61
19	0.91	30.63	20.83	20.30	0.72
24	2.09	20.07	9.93	9.19	2.09
26	3.18	15.02	8.34	6.98	3.87
30	10.47	3.27	14.35	2.09	21.03
35	20.82	1.41	18.71	0.78	16.53
40	28.46	0.94	22.53	0.53	21.28
42	31.18	0.83	24.48	0.48	23.62
50	40.41	0.58	31.95	0.36	26.67
100	70.27	0.22	34.43	0.14	26.71
250	75.32	0.12	38.09	0.05	37.16
500	78.57	0.13	32.71	0.07	33.02
600	75.89	0.14	30.70	0.08	31.08
700	72.50	0.15	29.18	0.10	29.28
800	69.32	0.16	27.65	0.11	27.79
1000	64.63	0.19	25.21	0.14	25.16
1500	56.38	0.28	20.97	0.21	21.23
2000	50.44	0.48	17.81	0.26	19.06
2150	49.68	0.69	19.89	0.26	25.50
2200	48.90	0.55	20.83	0.27	25.25

Functional Schematic

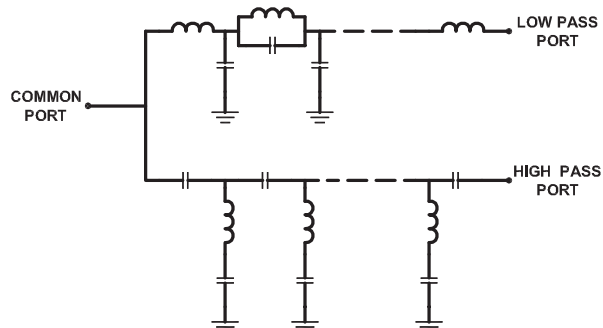

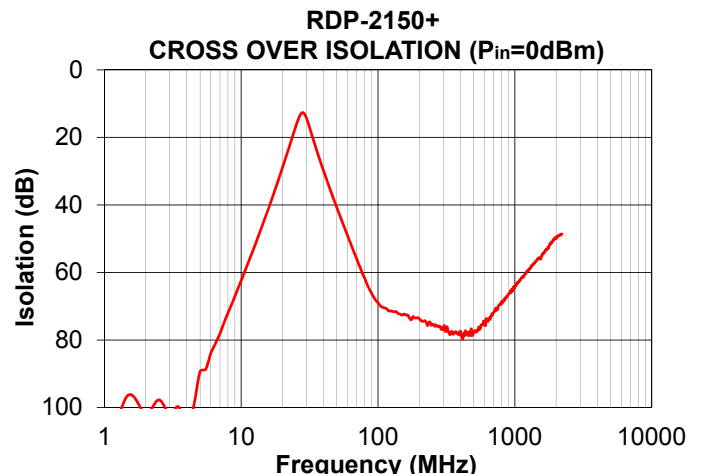
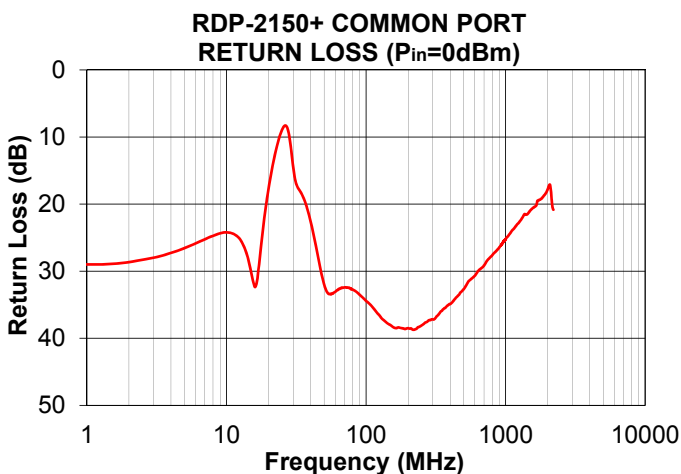
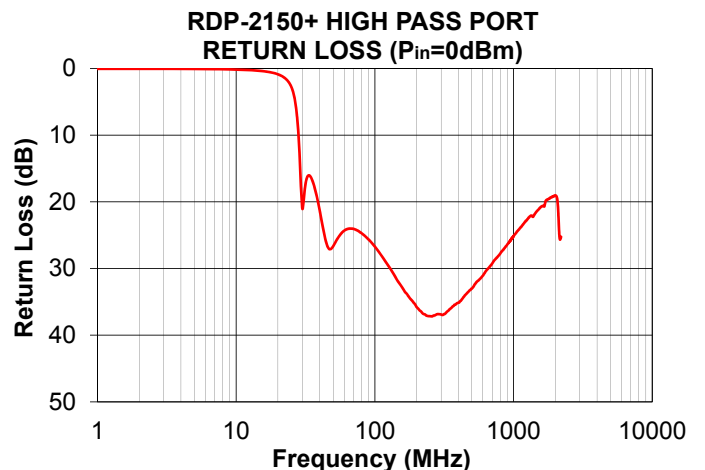
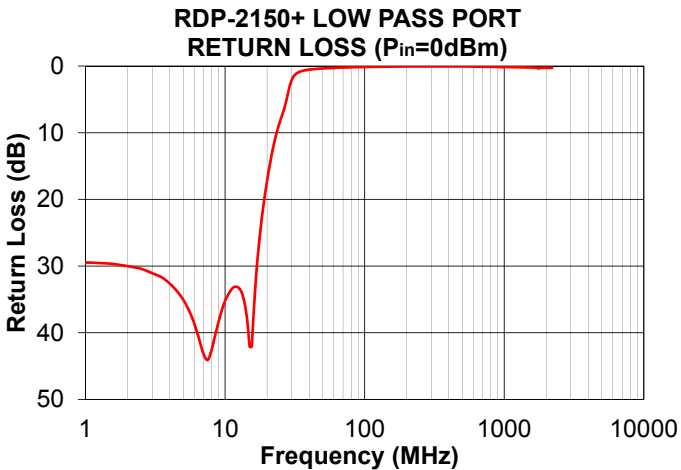
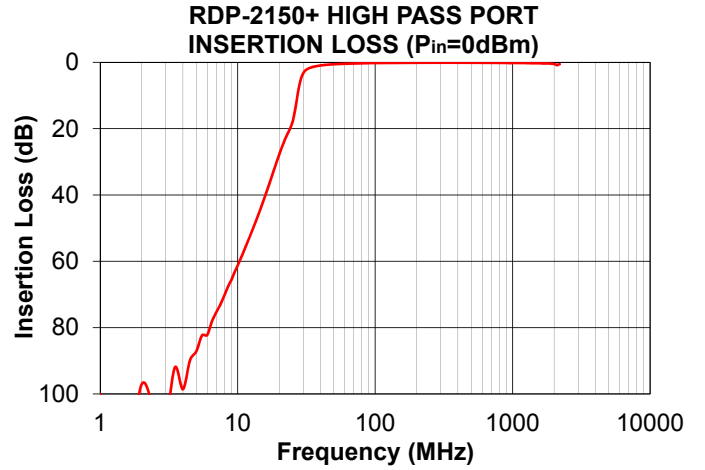
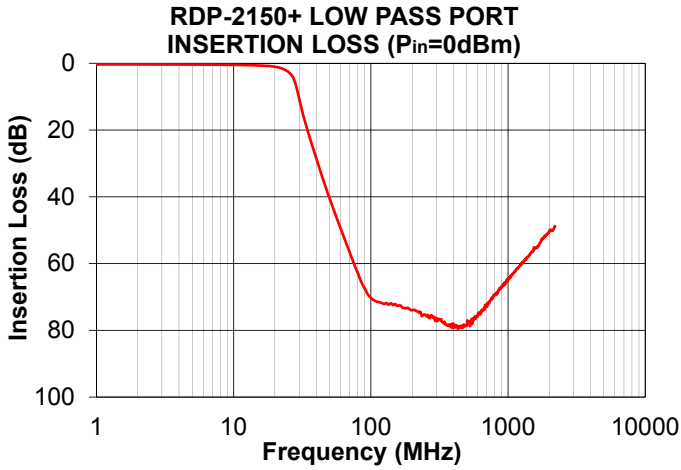

Notes

- A. Performance and quality attributes and conditions not expressly stated in this specification document are intended to be excluded and do not form a part of this specification document.
- B. Electrical specifications and performance data contained in this specification document are based on Mini-Circuits' applicable established test performance criteria and measurement instructions.
- C. The parts covered by this specification document are subject to Mini-Circuits standard limited warranty and terms and conditions (collectively, "Standard Terms"); Purchasers of this part are entitled to the rights and benefits contained therein. For a full statement of the Standard Terms and the exclusive rights and remedies thereunder, please visit Mini-Circuits' website at www.minicircuits.com/MCLStore/terms.jsp

