

# Voltage Controlled Oscillator

## ROS-3000-619+

5V Tuning for PLL ICs 2800 to 2970 MHz



CASE STYLE: CK605

### Features

- high power output, +10 dBm typ.
- linear tuning characteristics
- low phase noise, -101 dBc/Hz typ. @ 10kHz offset
- low pushing, 1.5 MHz/V typ.
- aqueous washable

### Applications

- wireless communications
- satellite systems

**+RoHS Compliant**  
The +Suffix identifies RoHS Compliance. See our web site for RoHS Compliance methodologies and qualifications

### Electrical Specifications

MODEL NO.	FREQ. (MHz)		POWER OUTPUT (dBm)	PHASE NOISE dBc/Hz SSB at offset frequencies, kHz				TUNING					NON HARMONIC SPURIOUS (dBc)		HARMONICS (dBc)		PULLING pk-pk @12 dB (MHz)	PUSHING (MHz/V)	DC OPERATING POWER		
	Min.	Max.		Typ.	1	10	100	1000	VOLTAGE RANGE (V)		SENSI- TIVITY (MHz/V)	PORT CAP (pF)	3 dB MODULATION BANDWIDTH (MHz)	Typ.	Typ.	Typ.			Max.	Vcc	Current (mA)
									Min.	Max.											
ROS-3000-619+	2800	2970	+10	-72	-101	-123	-144	0.5	5	50-70	13	150	-90	-25	-15	4	1.5	5	36		

### Pin Connections

RF OUT	10
VCC	14
V-TUNE	2
GROUND	1,3,4,5,6,7,8,9,11,12,13,15,16

### Maximum Ratings

Operating Temperature	-55°C to 85°C
Storage Temperature	-55°C to 100°C
Absolute Max. Supply Voltage (Vcc)	7V
Absolute Max. Tuning Voltage (Vtune)	7V
All specifications	50 ohm system

Permanent damage may occur if any of these limits are exceeded.

### Tape & Reel: F37

7" Reels with 10, 20, 50, 100 devices  
13" Reels with 200, 500 devices

### Environmental Ratings: ENV65

### Outline Drawing

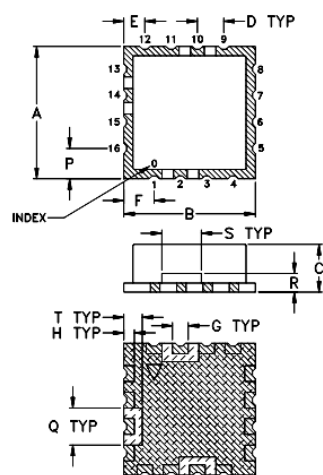

### PCB Land Pattern

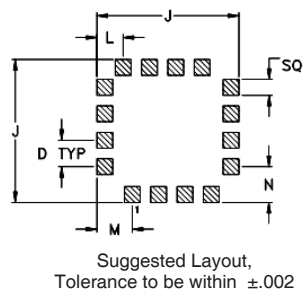

METALLIZATION  
 SOLDER RESIST

### Demo Board MCL P/N: TB-10 Suggested PCB Layout (PL-012)

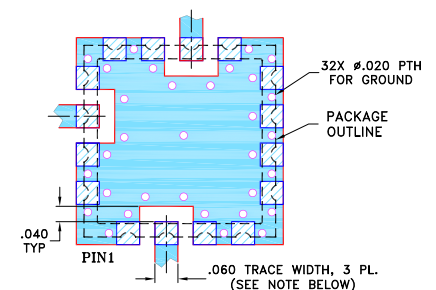

#### NOTES:

1. TRACE WIDTH IS SHOWN FOR FR4 WITH DIELECTRIC THICKNESS .030" ± .002"; COPPER: 1/2 OZ. EACH SIDE. FOR OTHER MATERIALS TRACE WIDTH MAY NEED TO BE MODIFIED.
  2. BOTTOM SIDE OF THE BOTTOM IS CONTINUOUS GROUND PLANE.
- DENOTES PCB COPPER LAYOUT WITH SMOBC (SOLDER MASK OVER BARE COPPER)  
 DENOTES COPPER LAND PATTERN FREE OF SOLDER MASK

### Outline Dimensions (inch/mm)

A	B	C	D	E	F	G	H	J	K	L	M	N	P	Q	R	S	T	wt.
.500	.500	.180	.100	.080	.115	.060	.040	.540	.060	.100	.135	.135	.115	.140	.070	.150	.070	grams
12.70	12.70	4.57	2.54	2.03	2.92	1.52	1.02	13.72	1.52	2.54	3.43	3.43	2.92	3.56	1.78	3.81	1.78	1.0

V TUNE	TUNE SENS (MHz/V)	FREQUENCY (MHz)			POWER OUTPUT (dBm)			I <sub>cc</sub> (mA)	HARMONICS (dBc)			FREQ. PUSH (MHz/V)	FREQ. PULL (MHz)	PHASE NOISE (dBc/Hz) at offsets				FREQ OFFSET (kHz)	PHASE NOISE at 2885 MHz (dBc/Hz)
		-55°C	+25°C	+85°C	-55°C	+25°C	+85°C		F2	F3	F4			1kHz	10kHz	100kHz	1MHz		
0.00	70.14	2737.3	2720.4	2709.8	9.47	9.50	9.33	30.78	-31.5	-27.4	-38.3	0.06	2.92	-73.48	-102.2	-124.7	-144.9	1.0	-74.51
0.50	60.94	2770.0	2754.3	2744.3	9.32	9.63	9.57	30.76	-29.8	-26.7	-41.7	0.41	0.80	-73.29	-102.2	-124.7	-145.2	2.0	-81.10
0.75	57.59	2784.6	2769.6	2760.0	9.34	9.54	9.53	30.82	-29.3	-27.0	-42.9	0.43	1.89	-74.25	-102.5	-125.0	-145.4	3.5	-88.00
1.00	57.12	2799.1	2784.0	2774.8	9.45	9.53	9.44	30.84	-30.5	-27.8	-44.8	0.45	2.33	-73.93	-102.4	-125.3	-145.7	6.0	-94.49
1.25	59.33	2813.9	2798.2	2789.0	9.53	9.63	9.46	30.80	-32.1	-28.2	-48.2	0.51	2.26	-73.61	-102.0	-124.7	-144.9	8.5	-99.00
1.50	59.09	2828.7	2813.1	2803.3	9.51	9.72	9.54	30.77	-33.0	-28.2	-48.3	0.52	1.41	-72.22	-101.5	-124.5	-144.9	10.0	-100.91
1.75	56.86	2842.8	2827.8	2818.2	9.42	9.74	9.61	30.74	-31.9	-26.7	-49.3	0.65	0.93	-72.25	-101.4	-124.3	-145.2	20.8	-108.90
2.00	58.82	2857.1	2842.1	2832.6	9.40	9.66	9.58	30.75	-31.1	-25.9	-50.3	0.68	2.03	-73.29	-101.2	-124.8	-145.4	35.5	-114.38
2.25	60.22	2871.9	2856.8	2847.2	9.37	9.66	9.55	30.78	-31.5	-24.7	-50.6	0.69	3.20	-73.54	-101.5	-124.9	-145.3	60.7	-119.42
2.50	62.80	2887.4	2871.8	2862.1	9.48	9.64	9.53	30.79	-32.2	-24.9	-51.5	0.71	2.81	-71.85	-101.3	-124.5	-145.3	86.7	-123.02
2.75	64.05	2903.3	2887.5	2877.4	9.65	9.73	9.53	30.77	-33.5	-24.0	-53.2	0.73	1.31	-72.22	-100.8	-124.7	-144.8	100.0	-124.46
3.00	67.78	2920.0	2903.5	2893.4	9.74	9.88	9.63	30.71	-34.2	-24.4	-55.0	0.67	1.16	-70.57	-100.7	-124.3	-145.0	148.1	-128.06
3.25	68.54	2936.9	2920.5	2909.7	9.72	9.97	9.79	30.67	-35.5	-23.8	-57.0	0.46	2.38	-72.44	-100.1	-124.1	-144.5	177.0	-129.48
3.50	66.67	2953.6	2937.6	2926.9	9.69	9.95	9.86	30.71	-36.9	-23.6	-60.1	0.06	2.65	-72.37	-100.4	-124.2	-145.3	211.6	-131.26
3.75	65.72	2970.1	2954.3	2943.9	9.81	9.88	9.85	30.73	-37.2	-24.2	-60.2	0.82	1.96	-71.55	-99.8	-123.3	-144.4	302.4	-134.94
4.00	65.28	2986.6	2970.7	2960.4	9.96	9.92	9.82	30.68	-38.2	-26.0	-62.9	1.80	0.62	-72.47	-99.0	-123.0	-143.6	361.5	-135.68
4.25	63.96	3002.8	2987.0	2976.6	9.97	9.98	9.87	30.62	-37.3	-27.8	-62.6	2.88	2.91	-70.01	-98.6	-122.1	-142.9	507.5	-138.84
4.50	61.50	3018.5	3003.0	2992.7	9.93	9.98	9.91	30.58	-34.8	-28.6	-61.4	3.97	4.32	-68.61	-97.3	-121.1	-141.6	606.7	-140.64
4.75	56.83	3033.1	3018.4	3008.2	9.89	9.96	9.88	30.57	-33.3	-30.1	-61.5	4.94	3.17	-67.71	-96.3	-120.3	-141.0	851.6	-143.68
5.00	52.89	3047.0	3032.6	3022.8	9.81	9.96	9.88	30.57	-32.0	-31.7	-59.6	5.76	0.38	-69.73	-96.1	-120.0	-140.7	1000.0	-143.68

\*at 25°C unless mentioned otherwise

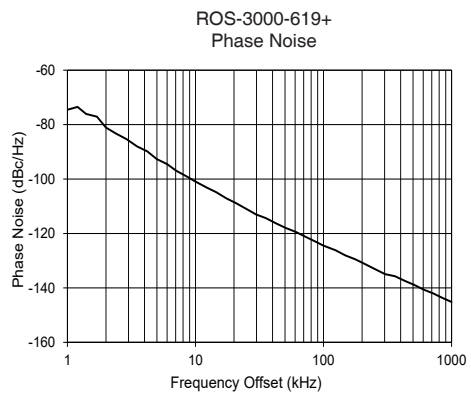
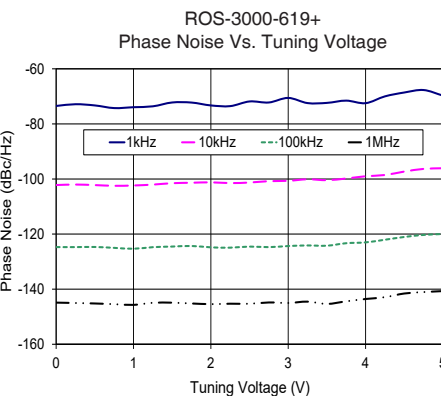
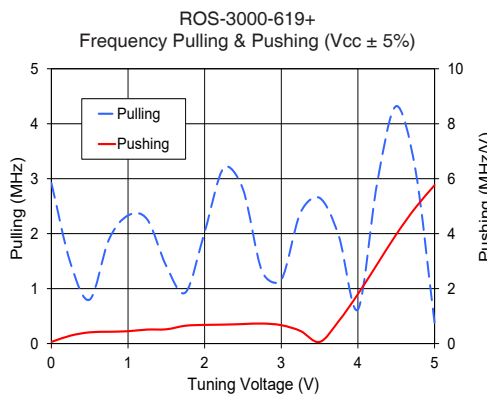
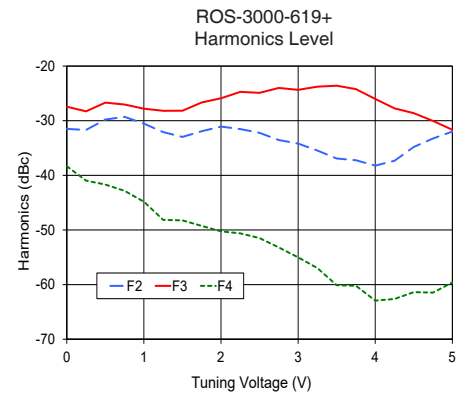
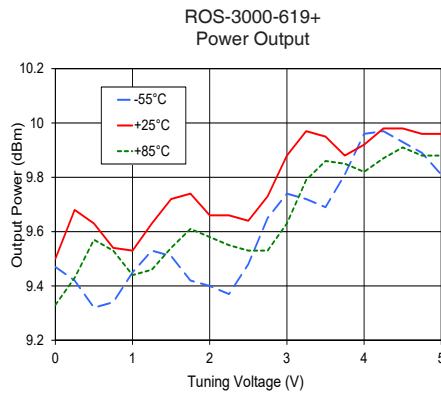
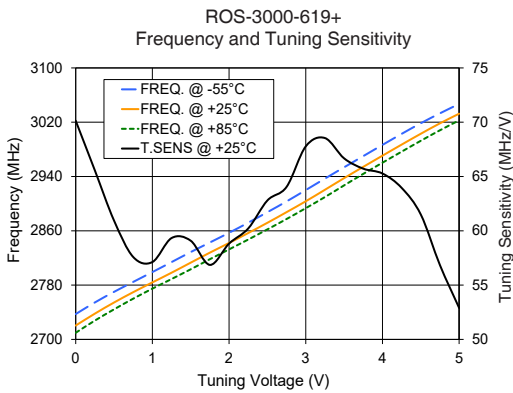

## Additional Notes

- Performance and quality attributes and conditions not expressly stated in this specification document are intended to be excluded and do not form a part of this specification document.
- Electrical specifications and performance data contained in this specification document are based on Mini-Circuit's applicable established test performance criteria and measurement instructions.
- The parts covered by this specification document are subject to Mini-Circuits standard limited warranty and terms and conditions (collectively, "Standard Terms"); Purchasers of this part are entitled to the rights and benefits contained therein. For a full statement of the Standard Terms and the exclusive rights and remedies thereunder, please visit Mini-Circuits' website at [www.minicircuits.com/MCLStore/terms.jsp](http://www.minicircuits.com/MCLStore/terms.jsp)

