

# Voltage Controlled Oscillator ROS-485-119R+

50Ω 450 to 485 MHz

## The Big Deal:

- Low Phase Noise
- Good Pulling & Pushing
- Robust design and construction
- Small size .500" x .500" x .180"



CASE STYLE: CK605

## Product Overview:

The ROS-485-119R+ is a Voltage Controlled Oscillator, designed to operate from 450 to 485 MHz for point-to-multipoint applications. The ROS-485-119R+ is packaged in a metal case (size of .500" x .500" x .180") to shield against unwanted signals and noise.

## Key Features

Feature	Advantages
Linear Tuning Sensitivity Ratio: 1.1:1 typ.	Optimal for loop filter design.
Low Phase Noise: -119dBc/Hz typ at 10kHz offset	Low phase noise improves system EVM (Error Vector Magnitude).
Good Pulling, 0.2 MHz typ.	Improves immunity against changes in output load.
Good Pushing, 0.4 MHz/V typ.	Provides increased immunity against noisy DC lines and improves output frequency stability vs. variations in supply voltage.
Robust design and construction	Each internal component of the ROS-485-119R+ is bonded to the substrate, providing better immunity to microphonics, reduced phase hit, and decreased tombstoning risk during subsequent reflow operations.
Small size, .500" x .500" x .180"	The small size enables the ROS-485-119R+ to be used in compact designs.

# Voltage Controlled Oscillator

## ROS-485-119R+

5V Tuning for PLL IC's 450 to 485 MHz

### Features

- low phase noise, -119 dBc/Hz typ. @ 10kHz offset
- linear tuning characteristics
- low pulling, 0.2 MHz typ.
- low pushing, 0.4 MHz/V typ.
- aqueous washable

### Applications

- wireless communications
- point-to-multipoint



CASE STYLE: CK605

**+RoHS Compliant**  
The +Suffix identifies RoHS Compliance. See our web site for RoHS Compliance methodologies and qualifications

### Electrical Specifications

MODEL NO.	FREQ. (MHz)		POWER OUTPUT (dBm)	PHASE NOISE dBc/Hz SSB at offset frequencies, kHz				TUNING					NON HARMONIC SPURIOUS (dBc)	HARMONICS (dBc)		PULLING pk-pk @12 dB (MHz)	PUSHING (MHz/V)	DC OPERATING POWER				
	Min.	Max.		Typ.	1	10	100	1000	VOLTAGE RANGE (V)	SENSITIVITY (MHz/V)	PORT CAP (pF)	3 dB MODULATION BANDWIDTH (MHz)		Typ.	Typ.			Max.	Typ.	Max.	Vcc (volts)	Current (mA)
	Typ.																					
ROS-485-119R+	450	485	+4.5	-89	-119	-139	-159	0.25	5	11-12	135	20	-90	-20	-10	0.2	0.4	5	28			

### Pin Connections

RF OUT	10
VCC	14
V-TUNE	2
GROUND	1,3,4,5,6,7,8,9,11,12,13,15,16

### Maximum Ratings

Operating Temperature	-55°C to 85°C
Storage Temperature	-55°C to 100°C
Absolute Max. Supply Voltage (Vcc)	7V
Absolute Max. Tuning Voltage (Vtune)	7V
All specifications	50 ohm system

Permanent damage may occur if any of these limits are exceeded.

### Tape & Reel: F37

7" Reels with 10, 20, 50, 100 devices  
13" Reels with 200, 500 devices

### Environmental Ratings: ENV65

### Outline Drawing

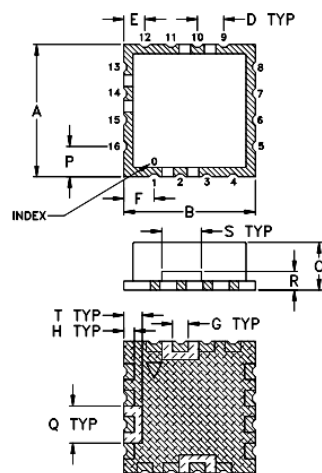

### PCB Land Pattern

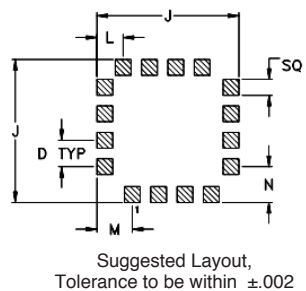

METALLIZATION  
 SOLDER RESIST

### Demo Board MCL P/N: TB-10 Suggested PCB Layout (PL-012)

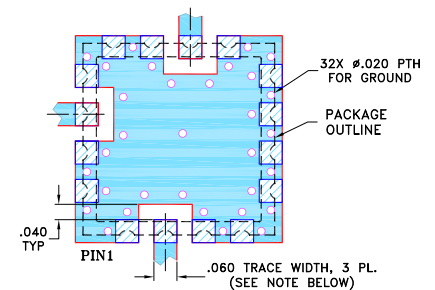

#### NOTES:

1. TRACE WIDTH IS SHOWN FOR FR4 WITH DIELECTRIC THICKNESS .030" ± .002"; COPPER: 1/2 OZ. EACH SIDE. FOR OTHER MATERIALS TRACE WIDTH MAY NEED TO BE MODIFIED.
  2. BOTTOM SIDE OF THE BOTTOM IS CONTINUOUS GROUND PLANE.
- DENOTES PCB COPPER LAYOUT WITH SMOBC (SOLDER MASK OVER BARE COPPER)  
 DENOTES COPPER LAND PATTERN FREE OF SOLDER MASK

### Outline Dimensions (inch/mm)

A	B	C	D	E	F	G	H	J	K	L	M	N	P	Q	R	S	T	wt.
.500	.500	.180	.100	.080	.115	.060	.040	.540	.060	.100	.135	.135	.115	.140	.070	.150	.070	grams
12.70	12.70	4.57	2.54	2.03	2.92	1.52	1.02	13.72	1.52	2.54	3.43	3.43	2.92	3.56	1.78	3.81	1.78	1.0

V TUNE	TUNE SENS (MHz/V)	FREQUENCY (MHz)			POWER OUTPUT (dBm)			Icc (mA)	HARMONICS (dBc)			FREQ. PUSH (MHz/V)	FREQ. PULL (MHz)	PHASE NOISE (dBc/Hz) at offsets				FREQ OFFSET (kHz)	PHASE NOISE at 468 MHz (dBc/Hz)
		-55°C	+25°C	+85°C	-55°C	+25°C	+85°C		F2	F3	F4			1kHz	10kHz	100kHz	1MHz		
0.00	15.10	439.6	437.1	435.3	4.08	3.90	3.01	20.85	-19.2	-42.8	-40.7	0.28	0.37	-89.79	-115.3	-136.2	-156.0	1.0	-92.62
0.25	13.60	443.2	440.8	439.3	4.35	4.19	3.35	21.19	-19.0	-43.8	-38.2	0.25	0.33	-89.82	-116.7	-137.2	-157.2	2.0	-99.08
0.50	12.68	446.5	444.2	442.8	4.56	4.38	3.55	21.45	-19.2	-44.0	-36.3	0.23	0.31	-88.98	-116.8	-137.7	-157.6	3.5	-108.02
0.75	12.09	449.6	447.4	446.0	4.72	4.51	3.69	21.67	-19.1	-45.5	-35.0	0.22	0.28	-90.87	-117.4	-138.0	-157.7	6.0	-113.18
1.00	11.71	452.6	450.4	449.1	4.82	4.59	3.78	21.86	-19.0	-45.5	-34.1	0.22	0.26	-90.60	-117.8	-138.5	-158.2	8.5	-116.86
1.50	11.35	458.3	456.2	454.9	4.93	4.66	3.88	22.14	-19.1	-44.9	-33.2	0.22	0.20	-92.94	-118.4	-138.9	-158.6	10.0	-118.38
1.75	11.31	461.2	459.1	457.8	4.93	4.67	3.90	22.26	-19.2	-44.9	-32.7	0.22	0.18	-91.52	-118.6	-139.2	-160.2	20.8	-125.76
2.00	11.33	464.0	461.9	460.6	4.92	4.66	3.91	22.34	-19.7	-42.9	-32.0	0.22	0.15	-93.52	-118.4	-139.2	-159.4	35.5	-130.63
2.25	11.39	466.8	464.7	463.4	4.88	4.63	3.90	22.40	-19.6	-43.0	-31.3	0.22	0.12	-92.74	-118.7	-139.5	-159.3	60.7	-135.16
2.50	11.49	469.6	467.6	466.3	4.83	4.59	3.88	22.46	-20.4	-41.4	-30.9	0.23	0.09	-93.44	-118.5	-139.6	-159.1	86.7	-138.21
2.75	11.60	472.5	470.4	469.1	4.76	4.54	3.85	22.49	-20.3	-40.6	-30.8	0.24	0.06	-91.90	-119.3	-139.8	-159.8	100.0	-139.63
3.00	11.73	475.3	473.3	472.1	4.66	4.47	3.81	22.50	-20.8	-39.9	-30.9	0.26	0.07	-92.94	-119.1	-140.0	-160.1	148.1	-142.98
3.25	11.88	478.2	476.3	475.0	4.55	4.39	3.75	22.50	-21.8	-39.0	-30.7	0.28	0.10	-92.73	-119.4	-140.2	-160.8	177.0	-144.62
3.50	12.02	481.2	479.2	478.0	4.42	4.29	3.68	22.49	-21.7	-38.1	-30.5	0.31	0.16	-93.47	-119.4	-140.4	-159.6	211.6	-146.37
3.75	12.18	484.1	482.2	481.0	4.27	4.18	3.60	22.45	-22.2	-37.2	-30.3	0.34	0.21	-92.03	-119.7	-140.5	-160.3	302.4	-149.52
4.00	12.35	487.1	485.3	484.1	4.10	4.04	3.50	22.40	-23.3	-36.2	-30.4	0.37	0.27	-92.75	-119.6	-140.8	-160.0	361.5	-150.29
4.25	12.52	490.2	488.4	487.2	3.91	3.89	3.39	22.34	-23.1	-35.5	-31.0	0.41	0.31	-91.84	-119.9	-141.1	-159.6	507.5	-153.75
4.50	12.69	493.3	491.5	490.3	3.69	3.72	3.26	22.26	-23.5	-34.9	-31.8	0.45	0.35	-91.30	-119.8	-140.9	-160.5	606.7	-155.36
4.75	12.87	496.4	494.7	493.5	3.46	3.54	3.11	22.16	-23.8	-34.2	-32.3	0.48	0.37	-91.46	-119.6	-141.2	-161.1	851.6	-157.59
5.00	13.02	499.6	497.9	496.7	3.21	3.33	2.95	22.05	-24.4	-33.4	-32.6	0.51	0.38	-91.84	-119.2	-141.2	-159.9	1000.0	-160.25

\*at 25°C unless mentioned otherwise

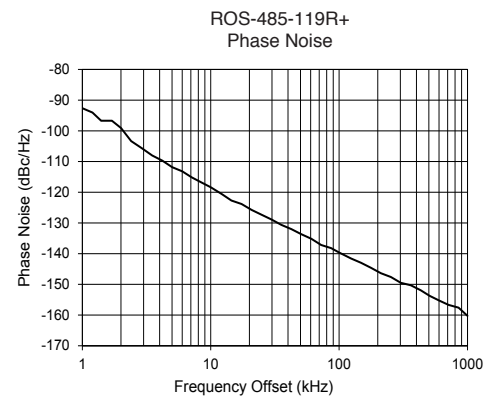
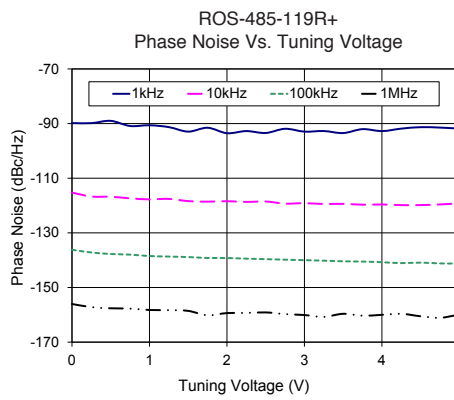
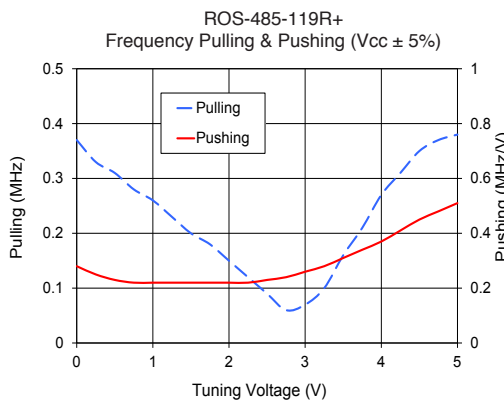
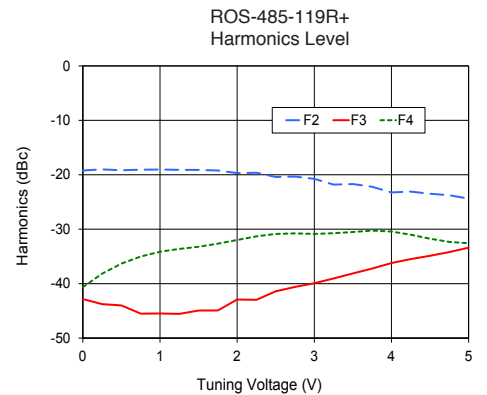
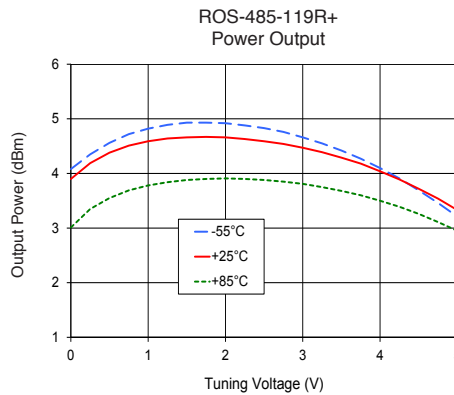
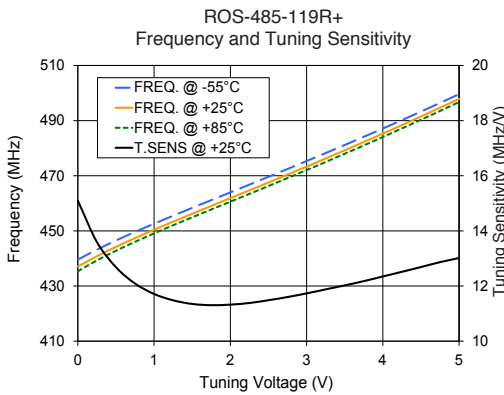

### Additional Notes

- Performance and quality attributes and conditions not expressly stated in this specification document are intended to specification document.
- Electrical specifications and performance data contained in this specification document are based on Mini-Circuit's ap measurement instructions.
- The parts covered by this specification document are subject to Mini-Circuits standard limited warranty and terms and Purchasers of this part are entitled to the rights and benefits contained therein. For a full statement of the Standard T thereunder, please visit Mini-Circuits' website at [www.minicircuits.com/MCLStore/terms.jsp](http://www.minicircuits.com/MCLStore/terms.jsp)

CHECK PRINT (FOR INTERNAL USE ONLY)			
MODEL: ROS-485-119R+ (X1)		Updated by Shimon A.	
NAME (PRINT)	SIGNATURE	DATE	FILE SIZE
Michael M		___ Oct. 2017	200 KB
David G.		___ Oct. 2017	
Haim H.		___ Oct. 2017	
Aharon S.		___ Oct. 2017	
David E.		___ Oct. 2017	

