

# REDUNDANT L-BAND AMPLIFIER

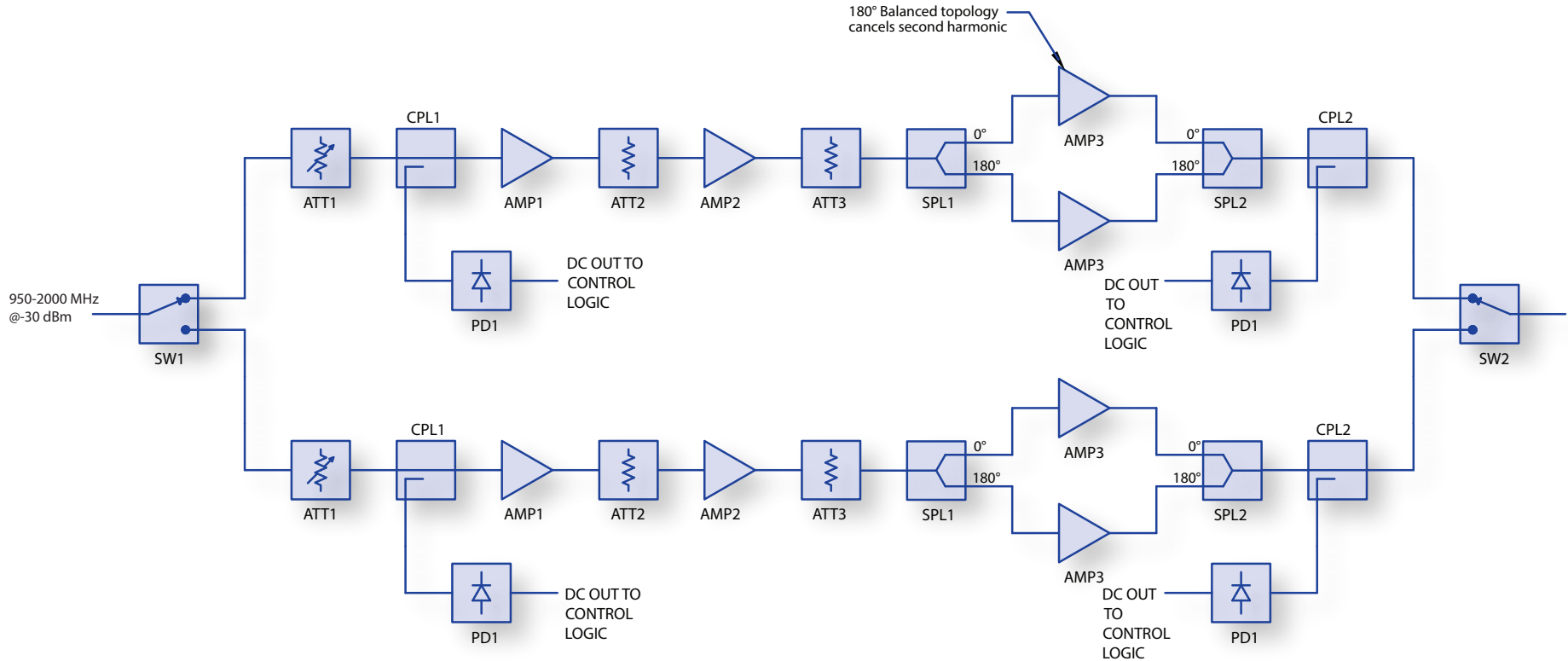

Schematic Part No.	Sample Mini-Circuits Model Families
AMP1	<a href="#">ZX60</a> , <a href="#">ZFL</a> , <a href="#">ZJL</a> , <a href="#">ZKL</a>
AMP2, AMP3	<a href="#">ZX60</a> , <a href="#">ZHL</a>
ATT1	<a href="#">ZX76</a>
ATT2, ATT3	<a href="#">VAT</a> , <a href="#">FW</a> , <a href="#">BW</a>
CPL1, CPL2	<a href="#">ZFDC</a> , <a href="#">ZNDC</a> , <a href="#">ZHDC</a> , <a href="#">ZADC</a>
PD1	<a href="#">ZX47</a>
SPL1, SPL2	<a href="#">ZAPDJ</a> , <a href="#">ZAPD</a> , <a href="#">ZN2PD</a> , <a href="#">ZFSC</a>
SW1, SW2	<a href="#">MSP2T</a> , <a href="#">MSP2TA</a>