



Power Splitter/Combiner **SBTC-2-10-75LX+**

2 Way-0° 75Ω 10 to 1000 MHz

FEATURES

- Low Insertion Loss, 0.8 dB Typ.
- Excellent Amplitude Unbalance, 0.15 dB Typ.
- Very Good Phase Unbalance, 1.0 deg. Typ.
- Temperature Stable LTCC Base
- Small Size
- Low Cost
- Aqueous Washable
- Protected by US Patent 6,963,255

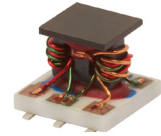

Generic photo used for illustration purposes only
CASE STYLE: AT1739

+RoHS Compliant
The +Suffix identifies RoHS Compliance.
See our website for methodologies and qualifications

APPLICATIONS

- UHF/VHF Receivers/Transmitters
- Cellular

ELECTRICAL SPECIFICATIONS AT +25°C

Parameter	Frequency (MHz)	Min.	Typ.	Max.	Unit
Frequency Range		10		1000	MHz
Insertion Loss Above 3.0 dB	10-100		0.7	1.2	dB
	100-500		0.6	1.2	
	500-1000		0.7	1.4	
Isolation	10-100	20	35		dB
	100-500	20	28		
	500-1000	17	21		
Phase Unbalance	10-100			3	Degree
	100-500			3	
	500-1000			5	
Amplitude Unbalance	10-100			0.7	dB
	100-500			0.6	
	500-1000			0.6	

ABSOLUTE MAXIMUM RATINGS

Parameter	Ratings
Operating Temperature	-40°C to +85°C
Storage Temperature	-55°C to +100°C
Power Input (as a Splitter)	0.5 W max.
Internal Dissipation	0.125 W max

Permanent damage may occur if any of these limits are exceeded.

ELECTRICAL SCHEMATIC

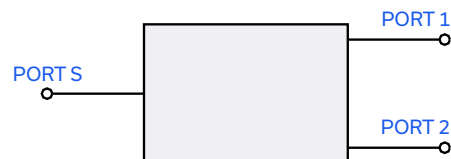



Power Splitter/Combiner **SBTC-2-10-75LX+**

PIN CONNECTIONS

SUM PORT	6
PORT 1	3
PORT 2	4
GROUND	1,2
NOT USED	5

PRODUCT MARKING: PV

DEMO BOARD MCL P/N: TB-277+
SUGGESTED PCB LAYOUT (PL-153)

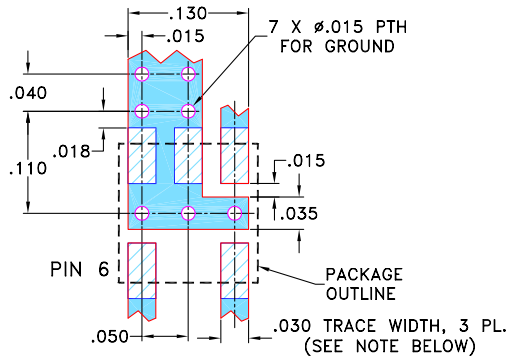

NOTE: 1. TRACE WIDTH IS SHOWN FOR ROGERS R04350B WITH DIELECTRIC THICKNESS $0.030" \pm 0.002"$; COPPER: 1/2 OZ. EACH SIDE. FOR OTHER MATERIALS TRACE WIDTH MAY NEED TO BE MODIFIED.

2. BOTTOM SIDE OF THE PCB IS CONTINUOUS GROUND PLANE.

- DENOTES PCB COPPER LAYOUT WITH SMOBC (SOLDER MASK OVER BARE COPPER)
- DENOTES COPPER LAND PATTERN FREE OF SOLDER MASK

OUTLINE DRAWING

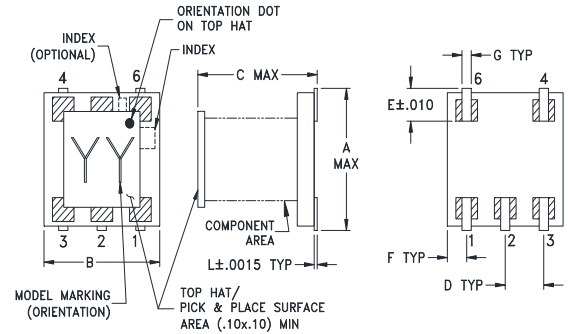

PCB Land Pattern

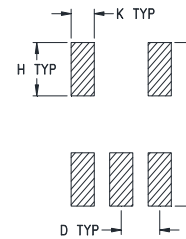

Suggested Layout,
Tolerance to be within $\pm .002$

OUTLINE DIMENSIONS (Inches/mm)

A	B	C	D	E	F
.166	.150	.155	.050	.037	.025
4.22	3.81	3.94	1.27	0.94	0.64
G	H	J	K	K	wt
.012	.060	.184	.030	.004	grams
0.30	1.52	4.67	0.76	0.10	0.10

TAPE & REEL INFORMATION: F76



Power Splitter/Combiner

SBTC-2-10-75LX+

2 Way-0° 75Ω 10 to 1000 MHz

TYPICAL PERFORMANCE DATA

Frequency (MHz)	Total Loss ¹ (dB)		Amplitude Unbalance (dB)	Isolation (dB)	Phase Unbalance (deg.)	VSWR (:1)		
	S-1	S-2				S	1	2
10	3.74	3.42	0.31	37.11	0.66	1.04	1.33	1.23
50	3.73	3.43	0.3	40.95	0.14	1.02	1.29	1.21
70	3.73	3.44	0.29	39.94	0.14	1.03	1.28	1.21
100	3.74	3.46	0.29	38.55	0.13	1.04	1.27	1.2
200	3.77	3.54	0.22	35.75	0.09	1.1	1.26	1.21
300	3.79	3.57	0.22	32.58	0.54	1.13	1.27	1.22
400	3.8	3.6	0.2	30.37	0.6	1.17	1.28	1.26
500	3.85	3.69	0.16	28.37	0.64	1.2	1.24	1.27
600	3.87	3.75	0.12	25.52	0.74	1.18	1.21	1.28
700	3.82	3.75	0.07	24.07	0.75	1.19	1.2	1.3
800	3.83	3.82	0.03	22.85	0.77	1.19	1.26	1.32
850	3.84	3.86	0.03	22.4	0.73	1.18	1.23	1.31
900	3.85	3.9	0.06	22.15	0.69	1.17	1.23	1.32
950	3.86	3.93	0.08	21.95	0.64	1.18	1.25	1.35
1000	3.86	3.98	0.11	21.68	0.58	1.18	1.25	1.35

1. Total Loss = Insertion Loss + 3 dB splitter loss.

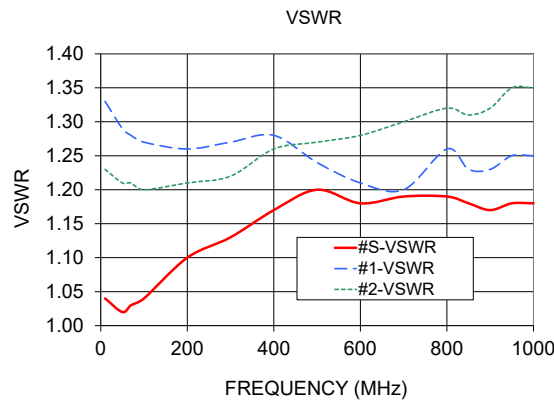
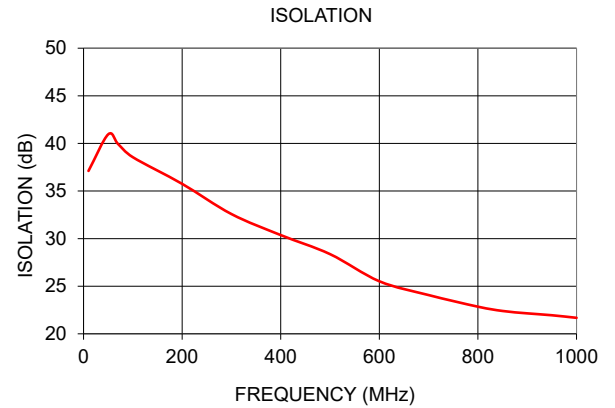
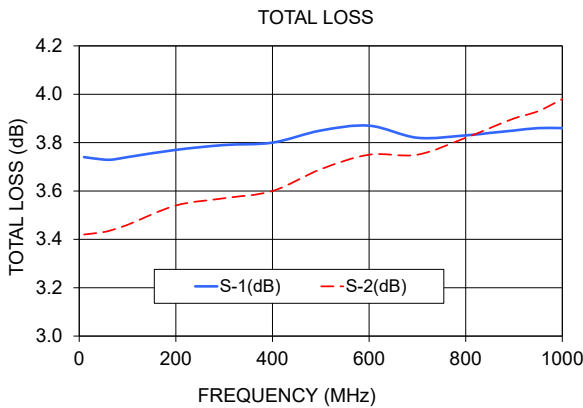

- NOTES**
- A. Performance and quality attributes and conditions not expressly stated in this specification document are intended to be excluded and do not form a part of this specification document.
 - B. Electrical specifications and performance data contained in this specification document are based on Mini-Circuit's applicable established test performance criteria and measurement instructions.
 - C. The parts covered by this specification document are subject to Mini-Circuits standard limited warranty and terms and conditions (collectively, "Standard Terms"); Purchasers of this part are entitled to the rights and benefits contained therein. For a full statement of the standard. Terms and the exclusive rights and remedies thereunder, please visit Mini-Circuits' website at www.minicircuits.com/terms/viewterm.html