



**SURFACE MOUNT**

# Power Splitter/Combiner

## SBTC-2-20+

Mini-Circuits

2 Way-0° 50Ω 200 to 2000 MHz

### FEATURES

- Low Insertion Loss, 0.3 dB Typ.
- Excellent Amplitude Unbalance, 0.1 dB Typ.
- Very Good Phase Unbalance, 1.0 deg. Typ.
- Temperature Stable LTCC Base
- Small Size
- Low Cost
- Aqueous Washable
- Protected by US Patent 6,963,255

For Model with Leads see [SBTC-2-20L+](#)



Generic photo used for illustration purposes only  
CASE STYLE: AT790

**+RoHS Compliant**  
The +Suffix identifies RoHS Compliance. See our website for methodologies and qualifications

### APPLICATIONS

- UHF/VHF Receivers/Transmitters
- Cellular

### ELECTRICAL SPECIFICATIONS AT +25°C

Parameter	Frequency (MHz)	Min.	Typ.	Max.	Unit
Frequency Range		200		2000	MHz
Insertion Loss Above 3.0 dB	200-2000		0.8	2.2	dB
	800-1000		0.5	0.9	
	500-1500		0.5	1.5	
	1800-2000		1.2	2.2	
Isolation	200-2000	14	20		dB
	800-1000	16	22		
	500-1500	15	22		
	1800-2000	15	20		
Phase Unbalance	200-2000			10	Degree
	800-1000			3	
	500-1500			5	
	1800-2000			10	
Amplitude Unbalance	200-2000			0.8	dB
	800-1000			0.5	
	500-1500			0.7	
	1800-2000			0.6	

### ABSOLUTE MAXIMUM RATINGS

Parameter	Ratings
Operating Temperature	-40°C to +85°C
Storage Temperature	-55°C to +100°C
Power Input (as a Splitter)	0.5 W max.
Internal Dissipation	0.125 W max

Permanent damage may occur if any of these limits are exceeded.

### ELECTRICAL SCHEMATIC

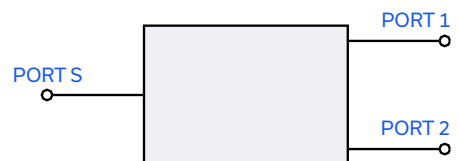

REV. G  
ECO-015187  
SBTC-2-20+  
MCL NY  
250414





# SURFACE MOUNT

# Power Splitter/Combiner

# SBTC-2-20+

Mini-Circuits

2 Way-0° 50Ω 200 to 2000 MHz

### PIN CONNECTIONS

SUM PORT	6
PORT 1	3
PORT 2	4
GROUND	1,2
NOT USED	5

### OUTLINE DRAWING

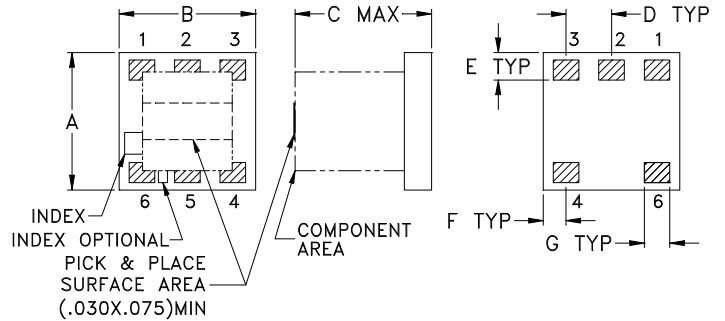

PRODUCT MARKING: N/A

DEMO BOARD MCL P/N: TB-274+  
SUGGESTED PCB LAYOUT (PL-152)

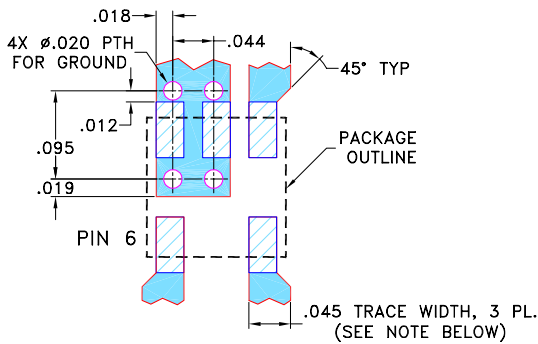

- NOTE: 1. TRACE WIDTH IS SHOWN FOR ROGERS RO4350B WITH DIELECTRIC THICKNESS  $0.020" \pm 0.0015"$ ; COPPER: 1/2 OZ. EACH SIDE. FOR OTHER MATERIALS TRACE WIDTH MAY NEED TO BE MODIFIED.  
2. BOTTOM SIDE OF THE PCB IS CONTINUOUS GROUND PLANE.

- DENOTES PCB COPPER LAYOUT WITH SMOBC (SOLDER MASK OVER BARE COPPER)
- DENOTES COPPER LAND PATTERN FREE OF SOLDER MASK

### PCB Land Pattern

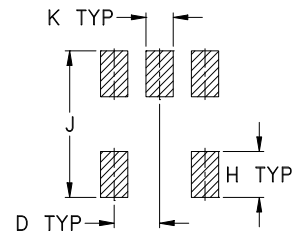

Suggested Layout,  
Tolerance to be within  $\pm 0.002$

### OUTLINE DIMENSIONS (Inches/mm)

A	B	C	D	E	F	G	H	J	K	wt grams
.150	.150	.150	.050	.030	.025	.028	.050	.160	.030	
3.81	3.81	3.81	1.27	0.76	0.64	0.71	1.27	4.06	0.76	0.10

### TAPE & REEL INFORMATION: F15



**SURFACE MOUNT**

# Power Splitter/Combiner

**SBTC-2-20+**

Mini-Circuits

2 Way-0° 50Ω 200 to 2000 MHz

### TYPICAL PERFORMANCE DATA

Frequency (MHz)	Total Loss <sup>1</sup> (dB)		Amplitude Unbalance (dB)	Isolation (dB)	Phase Unbalance (deg.)	VSWR (:1)		
	S-1	S-2				S	1	2
200.00	3.56	3.30	0.26	26.85	1.44	1.38	1.58	1.50
300.00	3.57	3.36	0.21	39.72	0.88	1.37	1.44	1.40
400.00	3.55	3.38	0.17	32.31	0.56	1.38	1.35	1.33
500.00	3.58	3.45	0.13	27.04	0.36	1.37	1.29	1.28
600.00	3.62	3.52	0.10	23.52	0.22	1.40	1.25	1.25
800.00	3.58	3.56	0.03	20.65	0.20	1.39	1.17	1.16
1000.00	3.61	3.68	0.07	19.36	0.41	1.37	1.12	1.08
1200.00	3.69	3.84	0.15	19.24	0.93	1.34	1.14	1.04
1400.00	3.76	3.98	0.22	20.40	1.78	1.30	1.23	1.13
1500.00	3.84	4.07	0.23	21.76	2.34	1.29	1.29	1.18
1600.00	3.92	4.16	0.24	24.12	2.94	1.28	1.35	1.23
1700.00	4.02	4.25	0.24	28.51	3.61	1.27	1.40	1.29
1800.00	4.15	4.36	0.21	31.25	4.31	1.27	1.45	1.34
1900.00	4.33	4.49	0.18	26.03	4.98	1.32	1.49	1.38
2000.00	4.57	4.66	0.16	20.75	5.63	1.40	1.51	1.42

1. Total Loss = Insertion Loss + 3 dB splitter loss.

TOTAL LOSS

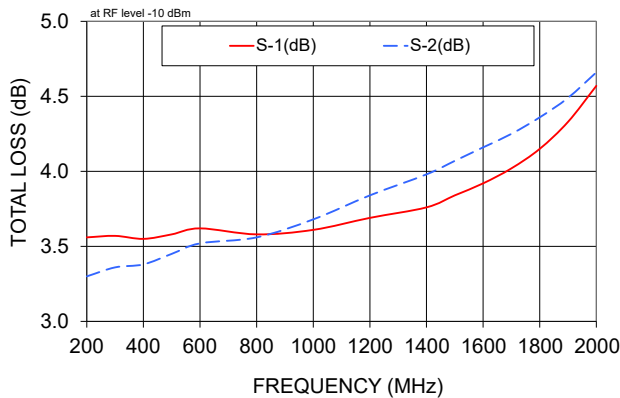

ISOLATION

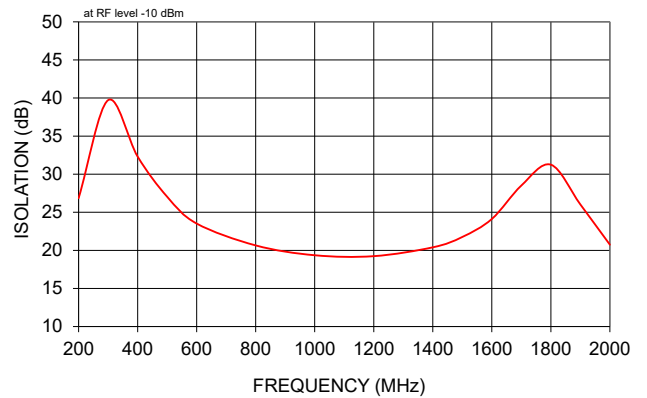

VSWR

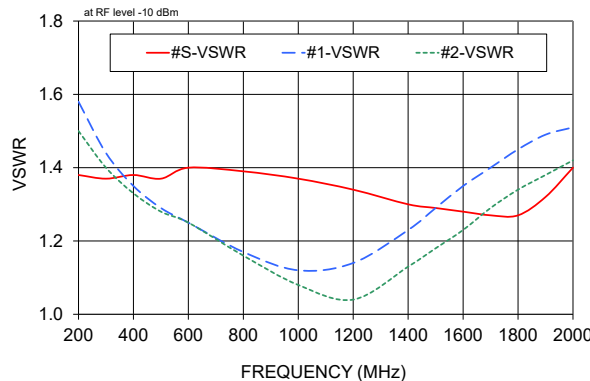

- NOTES**
- A. Performance and quality attributes and conditions not expressly stated in this specification document are intended to be excluded and do not form a part of this specification document.
  - B. Electrical specifications and performance data contained in this specification document are based on Mini-Circuit's applicable established test performance criteria and measurement instructions.
  - C. The parts covered by this specification document are subject to Mini-Circuits standard limited warranty and terms and conditions (collectively, "Standard Terms"); Purchasers of this part are entitled to the rights and benefits contained therein. For a full statement of the standard. Terms and the exclusive rights and remedies thereunder, please visit Mini-Circuits' website at [www.minicircuits.com/terms/viewterm.html](http://www.minicircuits.com/terms/viewterm.html)

