

top hat[®]
Surface Mount
Power Splitter/Combiner

SBTC-2-20X+

2 Way-0° 50Ω 200 to 2000 MHz

Features

- wide band frequency, 200-2000 MHz
- excellent amplitude unbalance, 0.2 dB typ.
- small size, 0.166"x0.15"x0.155"
- temperature stable LTCC base
- small size
- low cost
- aqueous washable
- protected by US patent 6,963,255

Applications

- cellular/GSM
- UHF/VHF receivers/transmitters
- PCN/PCS
- GPS



Generic photo used for illustration purposes only

CASE STYLE: AT1667

+RoHS Compliant

The +Suffix identifies RoHS Compliance. See our web site for RoHS Compliance methodologies and qualifications

Available Tape and Reel at no extra cost

Reel Size	Devices/Reel
13"	500

Electrical Specifications

Parameter	Frequency (MHz)	Min.	Typ.	Max.	Unit
Frequency Range		200		2000	MHz
Insertion Loss Above 3.0 dB	200 - 2000	—	0.8	2.2	dB
	800 - 1000	—	0.5	0.9	
	500 - 1500	—	0.5	1.5	
	1800 - 2000	—	1.2	2.2	
Isolation	200 - 2000	14	20	—	dB
	800 - 1000	16	22	—	
	500 - 1500	15	22	—	
	1800 - 2000	15	20	—	
Phase Unbalance	200 - 2000	—	—	10	Degree
	800 - 1000	—	—	3	
	500 - 1500	—	—	5	
	1800 - 2000	—	—	10	
Amplitude Unbalance	200 - 2000	—	—	0.8	dB
	800 - 1000	—	—	0.5	
	500 - 1500	—	—	0.7	
	1800 - 2000	—	—	0.6	

Maximum Ratings

Parameter	Ratings
Operating Temperature	-40°C to 85°C
Storage Temperature	-55°C to 100°C
Power Input (as a splitter)	0.5W max.
Internal Dissipation	0.125W max

Permanent damage may occur if any of these limits are exceeded.

Pin Connections

Function	Pin Number
SUM PORT	6
PORT 1	3
PORT 2	4
GROUND	1,2
NOT USED	5

Product Marking

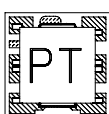

Electrical Schematic



Outline Drawing

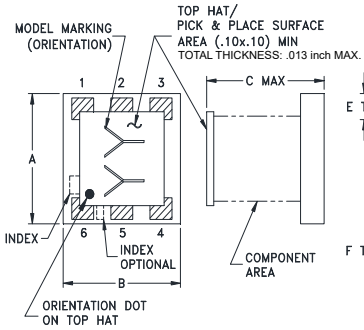

PCB Land Pattern

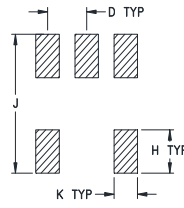

Suggested Layout,
Tolerance to be within ±.002

Outline Dimensions (inch/mm)

A	B	C	D	E	F
.150	.150	.150	.050	.030	.025
3.81	3.81	3.81	1.27	0.76	0.64
G	H	J	K	wt	
.028	.050	.160	.030	grams	
0.71	1.27	4.06	0.76	0.10	

Demo Board MCL P/N: TB-274 Suggested PCB Layout (PL-152)

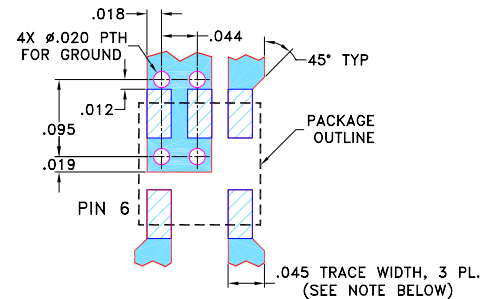

NOTE: 1. TRACE WIDTH IS SHOWN FOR ROGERS RO4350B WITH DIELECTRIC THICKNESS 0.020" ± 0.0015"; COPPER: 1/2 OZ. EACH SIDE. FOR OTHER MATERIALS TRACE WIDTH MAY NEED TO BE MODIFIED.
2. BOTTOM SIDE OF THE PCB IS CONTINUOUS GROUND PLANE.

- DENOTES PCB COPPER LAYOUT WITH SMOBC (SOLDER MASK OVER BARE COPPER)
- DENOTES COPPER LAND PATTERN FREE OF SOLDER MASK

Typical Performance Data

Frequency (MHz)	Total Loss ¹ (dB)		Amplitude Unbalance (dB)	Isolation (dB)	Phase Unbalance (deg.)	VSWR S	VSWR 1	VSWR 2
	S-1	S-2						
200.00	3.56	3.30	0.26	26.85	1.44	1.38	1.58	1.50
300.00	3.57	3.36	0.21	39.72	0.88	1.37	1.44	1.40
400.00	3.55	3.38	0.17	32.31	0.56	1.38	1.35	1.33
500.00	3.58	3.45	0.13	27.04	0.36	1.37	1.29	1.28
600.00	3.62	3.52	0.10	23.52	0.22	1.40	1.25	1.25
800.00	3.58	3.56	0.03	20.65	0.20	1.39	1.17	1.16
1000.00	3.61	3.68	0.07	19.36	0.41	1.37	1.12	1.08
1200.00	3.69	3.84	0.15	19.24	0.93	1.34	1.14	1.04
1400.00	3.76	3.98	0.22	20.40	1.78	1.30	1.23	1.13
1500.00	3.84	4.07	0.23	21.76	2.34	1.29	1.29	1.18
1600.00	3.92	4.16	0.24	24.12	2.94	1.28	1.35	1.23
1700.00	4.02	4.25	0.24	28.51	3.61	1.27	1.40	1.29
1800.00	4.15	4.36	0.21	31.25	4.31	1.27	1.45	1.34
1900.00	4.33	4.49	0.18	26.03	4.98	1.32	1.49	1.38
2000.00	4.57	4.66	0.16	20.75	5.63	1.40	1.51	1.42

1. Total Loss = Insertion Loss + 3dB splitter loss.

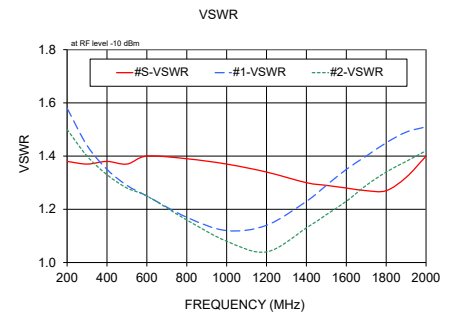
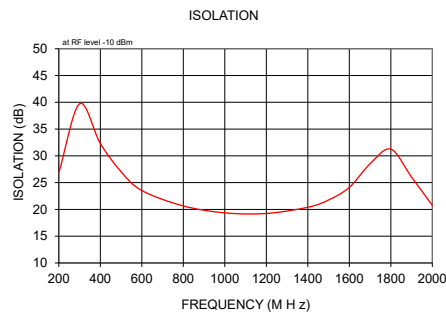
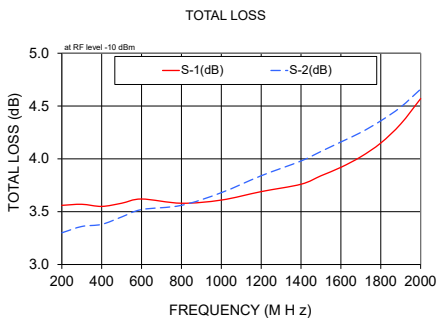

Additional Notes

- Performance and quality attributes and conditions not expressly stated in this specification document are intended to be excluded and do not form a part of this specification document.
- Electrical specifications and performance data contained in this specification document are based on Mini-Circuit's applicable established test performance criteria and measurement instructions.
- The parts covered by this specification document are subject to Mini-Circuits standard limited warranty and terms and conditions (collectively, "Standard Terms"); Purchasers of this part are entitled to the rights and benefits contained therein. For a full statement of the Standard Terms and the exclusive rights and remedies thereunder, please visit Mini-Circuits' website at www.minicircuits.com/MCLStore/terms.jsp