

Surface Mount Power Splitter/Combiner

SCPJ-2-9+

2 Way-180° 50Ω

200 to 900 MHz

Maximum Ratings

Operating Temperature	-40°C to 85°C
Storage Temperature	-55°C to 100°C
Power Input (as a splitter)	1W max.
Internal Dissipation	0.125W max.

Permanent damage may occur if any of these limits are exceeded.

Pin Connections

SUM PORT	1
PORT 1	5
PORT 2	6
GROUND	2,3,4,7,8

Outline Drawing

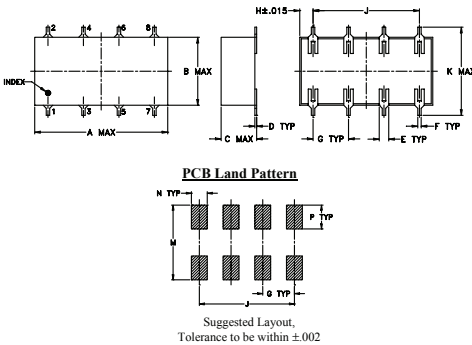

Outline Dimensions (inch/mm)

A	B	C	D	E	F	G	H	J	K	M	N	P	wt
0.75	0.38	0.28	0.01	0.05	0.02	0.2	0.075	0.6	0.45	0.47	0.1	0.15	grams
19.05	9.65	7.11	0.25	1.27	0.51	5.08	1.91	15.24	11.43	11.94	2.54	3.81	1.60

Demo Board MCL P/N: TB-50+ Suggested PCB Layout (PL-060)

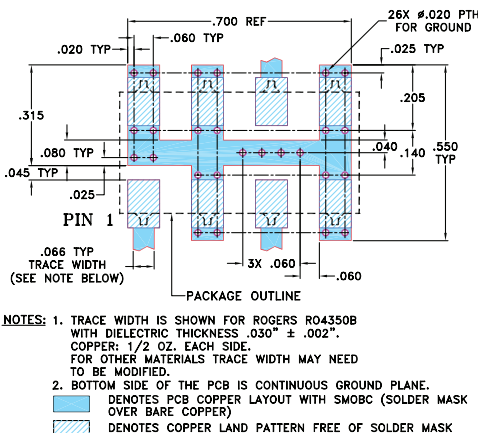

Notes

- Performance and quality attributes and conditions not expressly stated in this specification document are intended to be excluded and do not form a part of this specification document.
- Electrical specifications and performance data contained in this specification document are based on Mini-Circuit's applicable established test performance criteria and measurement instructions.
- The parts covered by this specification document are subject to Mini-Circuit's standard limited warranty and terms and conditions (collectively, "Standard Terms"); Purchasers of this part are entitled to the rights and benefits contained therein. For a full statement of the Standard Terms and the exclusive rights and remedies thereunder, please visit Mini-Circuit's website at www.minicircuits.com/MCLStore/terms.jsp

Features

- wideband, 200 to 900 MHz
- good isolation, 24 dB typ.
- excellent amplitude unbalance, 0.4 dB typ.

Applications

- VHF/UHF
- cellular
- communication systems



Generic photo used for illustration purposes only
CASE STYLE: YY161

+RoHS Compliant

The +Suffix identifies RoHS Compliance. See our web site for RoHS Compliance methodologies and qualifications

Electrical Specifications

FREQ. RANGE (MHz)	ISOLATION (dB)	INSERTION LOSS (dB) ABOVE 3 dB	PHASE UNBALANCE (Degrees)	AMPLITUDE UNBALANCE (dB)
f_L - f_U	Typ. Min.	Typ. Max.	Max.	Max.
200-900	24 17	1.0 1.8	6	0.7

Typical Performance Data

Frequency (MHz)	Total Loss ¹ (dB)		Amplitude Unbalance (dB)	Isolation (dB)	Phase Unbalance (deg.)	VSWR S	VSWR 1	VSWR 2
	S-1	S-2						
201.54	4.06	3.65	0.41	22.58	183.33	1.42	1.27	1.13
265.38	3.90	3.60	0.29	22.25	181.67	1.37	1.21	1.14
297.31	4.03	3.71	0.33	22.26	180.97	1.36	1.19	1.14
361.15	3.91	3.68	0.23	22.27	179.90	1.33	1.17	1.15
393.08	3.96	3.73	0.23	22.30	179.67	1.29	1.17	1.14
463.64	4.01	3.83	0.18	22.66	178.81	1.28	1.18	1.15
502.27	3.91	3.79	0.13	23.00	178.58	1.23	1.19	1.14
540.91	3.98	3.84	0.14	23.36	178.37	1.24	1.20	1.15
618.18	4.03	3.96	0.07	24.25	181.90	1.20	1.20	1.15
695.45	4.05	4.06	0.00	25.27	181.65	1.10	1.20	1.17
734.09	4.08	4.05	0.04	25.64	181.51	1.11	1.20	1.20
811.36	4.15	4.23	0.08	24.90	181.15	1.08	1.17	1.25
850.00	4.26	4.24	0.02	23.66	179.95	1.05	1.16	1.31
913.64	4.34	4.46	0.12	21.20	180.00	1.16	1.13	1.37

1. Total Loss = Insertion Loss + 3dB splitter loss.

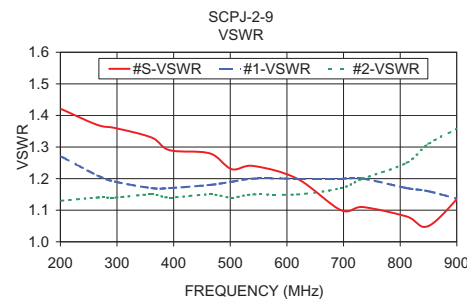
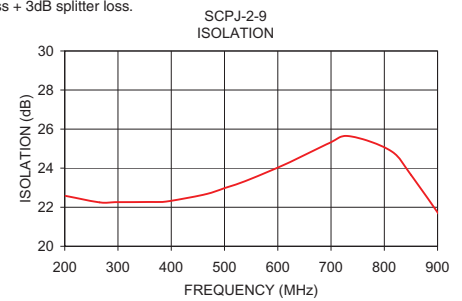
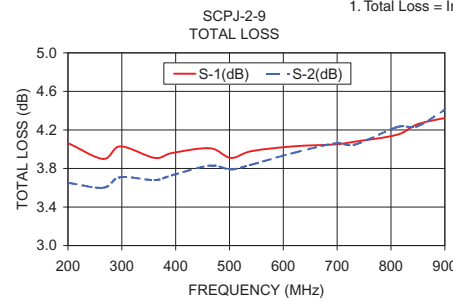

electrical schematic

