

Coaxial

Adapter *SMP-F to SMA-M*

SMPF-SM50+

50Ω DC to 18 GHz

The Big Deal

- Ultra-wideband, DC to 18 GHz
- Flat response
- Low insertion loss, 0.07 dB
- Excellent VSWR, 1.17:1



CASE STYLE: DJ2143

Product Overview

Mini-Circuits' SMPF-SM50+ is a coaxial SMP-F to SMA-M adapter supporting a wide range of applications from DC to 18 GHz. This model provides excellent VSWR, low insertion loss, and flat response versus frequency. The SMPF-SM50+ features passivated stainless steel (SMA side) and Gold-plated berillium copper construction (SMP side) and measures only 0.28" (l) x 0.70" (dia.)

Key Features

Feature	Advantages
Wideband, DC to 18 GHz	Wide frequency range provides application flexibility and makes this model ideal for broad-band and multi-band use.
Excellent VSWR, 1.17:1	Provides good matching for 50Ω systems and minimizes signal reflections across wide frequency range.
Low insertion loss, 0.07 dB	Provides excellent signal power transmission from input to output.
Passivated stainless steel (SMA side) and Gold-plated berillium copper construction (SMP side)	Stands up to wear and tear in demanding environments and provides excellent reliability.
Very wide operating temperature range, -55 to +100°C	Withstands extreme operating conditions and is suitable for use near high power components where heat rise is common.

Notes

- A. Performance and quality attributes and conditions not expressly stated in this specification document are intended to be excluded and do not form a part of this specification document.
B. Electrical specifications and performance data contained in this specification document are based on Mini-Circuit's applicable established test performance criteria and measurement instructions.
C. The parts covered by this specification document are subject to Mini-Circuits standard limited warranty and terms and conditions (collectively, "Standard Terms"); Purchasers of this part are entitled to the rights and benefits contained therein. For a full statement of the Standard Terms and the exclusive rights and remedies thereunder, please visit Mini-Circuits' website at www.minicircuits.com/MCLStore/terms.jsp



Coaxial Adapter *SMP-F to SMA-M*

50Ω DC to 18 GHz

SMPF-SM50+



Generic photo used for illustration purposes only
CASE STYLE: DJ2143

Connectors	Model
Conn1 SMP-F	Conn2 SMA-M
SMPF-SM50+	

+RoHS Compliant
The +Suffix identifies RoHS Compliance. See our web site for RoHS Compliance methodologies and qualifications

Maximum Ratings

Operating Temperature	-45°C to 100°C
Storage Temperature	-55°C to 100°C

Permanent damage may occur if any of these limits are exceeded.

Features

- low insertion loss, 0.07 dB
- excellent VSWR, 1.17
- low cost adapters, available from stock
- passivated stainless steel body (SMA) and gold-plated berillium copper (SMP)

Applications

- interconnection of RF cables and equipment

Electrical Specifications at 25°C

Parameter	Condition (GHz)	Min.	Typ.	Max.	Units
Frequency Range		DC		18	GHz
Insertion Loss	DC - 18	—	0.07	—	dB
	DC - 8	—	1.06	1.2	
VSWR	DC - 12.4	—	1.07	1.2	:1
	DC - 18	—	1.08	1.2	

Outline Drawing

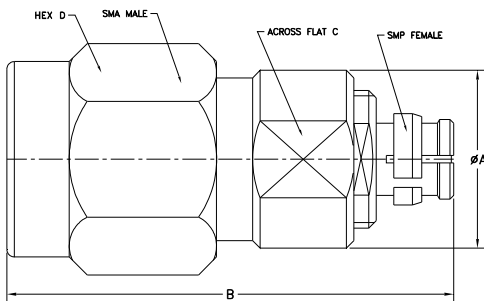

Case Material: Passivated stainless steel

Outline Dimensions (inch/mm)

A	B	C	D	wt
.28	.70	.250	.315	grams
7.112	17.78	6.35	8.001	3.3

Typical Performance Data

Frequency (MHz)	Insertion Loss (dB)	VSWR (:1)	
		SMP-F	SMA-M
10	0.00	1.00	1.00
50	0.00	1.01	1.00
100	0.01	1.00	1.00
1000	0.02	1.02	1.01
2000	0.03	1.02	1.02
3000	0.03	1.03	1.05
4000	0.04	1.02	1.08
5000	0.05	1.02	1.10
6000	0.05	1.02	1.10
8000	0.06	1.03	1.06
9000	0.06	1.04	1.03
10000	0.07	1.07	1.06
11000	0.08	1.10	1.11
12000	0.10	1.13	1.15
13000	0.10	1.15	1.17
15000	0.10	1.11	1.11
16000	0.10	1.05	1.04
18000	0.13	1.16	1.14

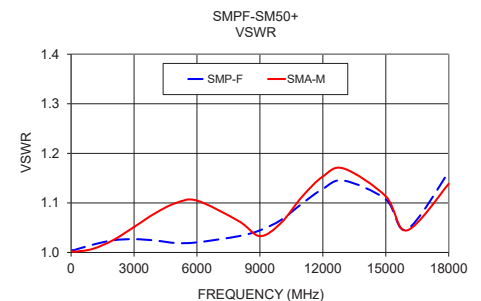
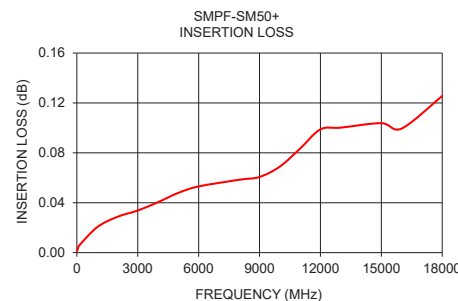

Notes

- Performance and quality attributes and conditions not expressly stated in this specification document are intended to be excluded and do not form a part of this specification document.
- Electrical specifications and performance data contained in this specification document are based on Mini-Circuit's applicable established test performance criteria and measurement instructions.
- The parts covered by this specification document are subject to Mini-Circuits standard limited warranty and terms and conditions (collectively, "Standard Terms"); Purchasers of this part are entitled to the rights and benefits contained therein. For a full statement of the Standard Terms and the exclusive rights and remedies thereunder, please visit Mini-Circuits' website at www.minicircuits.com/WCLStore/terms.jsp

