

# Plug-In RF Transformer

50Ω 0.3 to 120 MHz

## T16-1-X65+ T16-1-X65



Generic photo used for illustration purposes only  
CASE STYLE: X65

### +RoHS Compliant

The +Suffix identifies RoHS Compliance. See our web site for RoHS Compliance methodologies and qualifications

### Maximum Ratings

Operating Temperature	-20°C to 85°C
Storage Temperature	-55°C to 100°C
RF Power	0.25W
DC Current	30mA

Permanent damage may occur if any of these limits are exceeded.

### Pin Connections

PRIMARY DOT	4
PRIMARY	6
SECONDARY DOT	3
SECONDARY	1
SECONDARY CT	—
NOT USED	2,5

### Outline Drawing

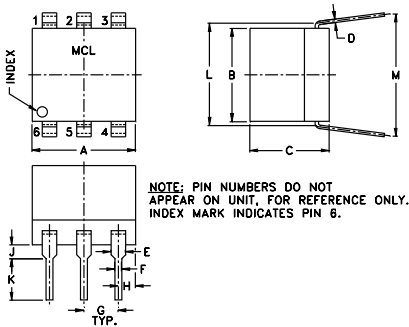

### Outline Dimensions (inch/mm)

A	B	C	D	E	F	G
.30	.27	.23	.010	.042	.020	.100
7.62	6.86	5.84	0.25	1.07	0.51	2.54
H	J	K	L	M	wt	
.05	.04	.11	.300	.35	grams	
1.27	1.02	2.79	7.62	8.89	0.50	

### Config. C

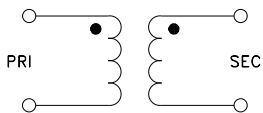

### Notes

- Performance and quality attributes and conditions not expressly stated in this specification document are intended to be excluded and do not form a part of this specification document.
- Electrical specifications and performance data contained in this specification document are based on Mini-Circuit's applicable established test performance criteria and measurement instructions.
- The parts covered by this specification document are subject to Mini-Circuits standard limited warranty and terms and conditions (collectively, "Standard Terms"); Purchasers of this part are entitled to the rights and benefits contained therein. For a full statement of the Standard Terms and the exclusive rights and remedies thereunder, please visit Mini-Circuits' website at [www.minicircuits.com/MCLStore/terms.jsp](http://www.minicircuits.com/MCLStore/terms.jsp)

### Features

- wideband, 0.3 to 120 MHz
- excellent return loss
- also available with flat-pack (W38) & surface mount gull-wing (KK81) leads

### Applications

- HF/VHF
- impedance matching
- receivers/transmitters

### Transformer Electrical Specifications

Ω RATIO (Secondary/Primary)	FREQUENCY (MHz)	INSERTION LOSS*		
		3 dB MHz	2 dB MHz	1 dB MHz
16	0.3-120	0.3-120	0.7-80	5-20

\*Insertion Loss is referenced to mid-band loss, 0.8 dB typ.

### Typical Performance Data

FREQUENCY (MHz)	INSERTION LOSS (dB)	INPUT R. LOSS (dB)
0.30	2.48	6.85
1.01	1.48	13.30
2.17	1.13	16.98
10.03	0.78	16.23
20.13	0.81	10.21
45.28	0.93	4.59
46.55	0.93	4.49
100.51	1.51	1.58
108.53	1.62	1.41
120.00	1.76	1.24

