



top hat
SURFACE MOUNT
RF Transformer

TCM2-33WX-2+

50Ω 10 to 3000 MHz

FEATURES

- Wide bandwidth, 10 to 3000 MHz
- Balanced transmission line
- Excellent return loss
- Aqueous washable
- Patent pending



Generic photo used for illustration purposes only

CASE STYLE: DB1627

APPLICATIONS

- PCS
- Wideband push-pull amplifiers
- Cellular

+RoHS Compliant
The +Suffix identifies RoHS Compliance.
See our website for methodologies and qualifications

ELECTRICAL SPECIFICATIONS AT 25°C

Parameter	Frequency (MHz)	Min.	Typ.	Max.	Units
Impedance Ratio (secondary/primary)		2			Ohm
Frequency Range		10		3000	MHz
Insertion Loss*	10-3000	—	1.5	3.0	dB
Amplitude Unbalance	10-3000	—	0.7	—	dB
Phase Unbalance	10-3000	—	4	—	Degree

* Insertion Loss is referenced to mid-band loss, 0.8 dB typ.

MAXIMUM RATINGS

Parameter	Ratings
Operating Temperature	-40°C to 85°C
Storage Temperature	-55°C to 100°C
RF Power	0.4 W
DC Current	30 mA

CONFIGURATION N

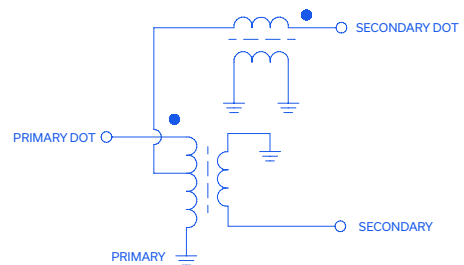

REV. A
ECO-013842
TCM2-33WX-2+
IG/CP/AM
220620



top hat®
SURFACE MOUNT
RF Transformer

TCM2-33WX-2+

Mini-Circuits®

50Ω 10 to 3000 MHz

PAD CONNECTIONS

PRIMARY DOT	6
PRIMARY	2
SECONDARY DOT	4
SECONDARY	3
GND	2,5
NOT USED	1

PRODUCT MARKING: GT

DEMOBOARD MCL P/N: TB-TCM2-33WX-2+
SUGGESTED PCB LAYOUT (PL-364)

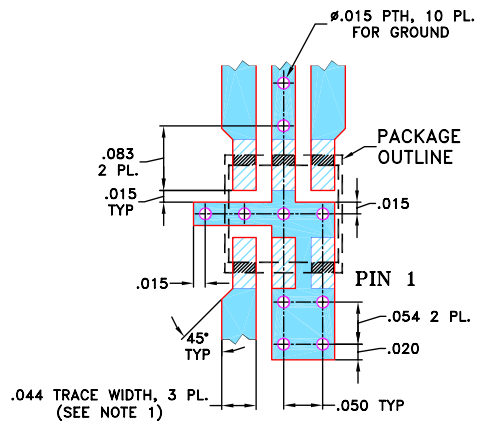

- NOTES: 1. TRACE WIDTH IS SHOWN FOR ROGERS RO4350B WITH DIELECTRIC THICKNESS .020" ± .0015"; COPPER: 1/2 OZ. ON EACH SIDE. FOR OTHER MATERIALS TRACE WIDTH MAY NEED TO BE MODIFIED.
2. BOTTOM SIDE OF THE PCB IS CONTINUOUS GROUND PLANE.
- DENOTES PCB COPPER LAYOUT WITH SMOBC (SOLDER MASK OVER BARE COPPER)
 - DENOTES COPPER LAND PATTERN FREE OF SOLDER MASK

OUTLINE DRAWING

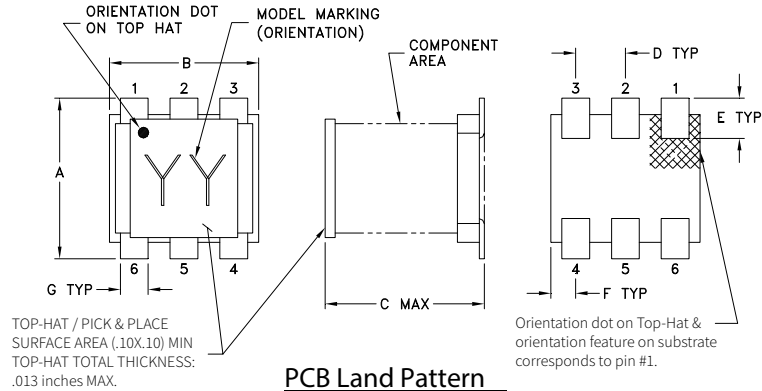

PCB Land Pattern

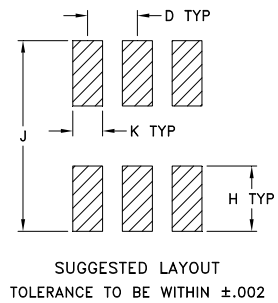

OUTLINE DIMENSIONS (Inches/mm)

A	B	C	D	E	F
.160	.150	.160	.050	.040	.025
4.06	3.81	4.06	1.27	1.02	0.64
G	H	J	K	wt	
.028	.065	.190	.030	grams	
0.71	1.65	4.83	0.76	0.15	

TAPE & REEL INFORMATION: F47



top hat[®]
SURFACE MOUNT
RF Transformer

TCM2-33WX-2+

50Ω 10 to 3000 MHz

TYPICAL PERFORMANCE DATA

Frequency (MHz)	Insertion Loss (dB)	Return Loss (dB)	Amplitude Unbalance (dB)	Phase Unbalance (deg)
10	0.87	21.66	0.03	0.01
100	0.78	28.58	0.03	0.04
400	0.95	21.26	0.05	0.82
700	1.12	18.13	0.12	0.83
1000	1.30	16.31	0.26	0.62
1600	1.72	14.75	0.74	1.70
2000	2.01	14.79	0.90	2.62
2500	2.46	15.01	0.79	1.26
2800	2.74	14.33	0.64	0.80
3000	2.93	13.77	0.54	1.09

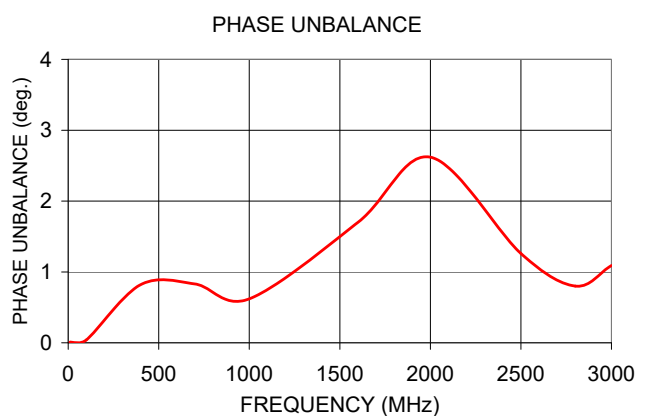
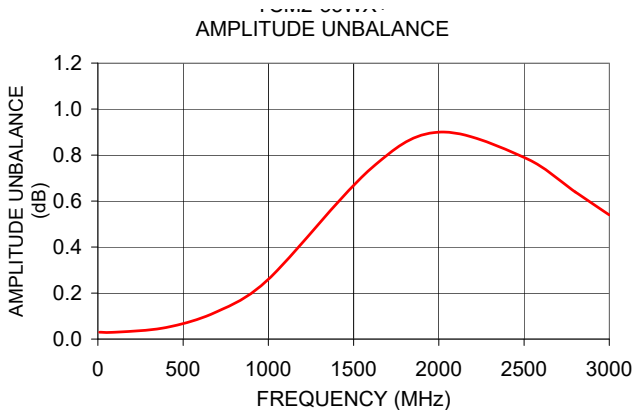
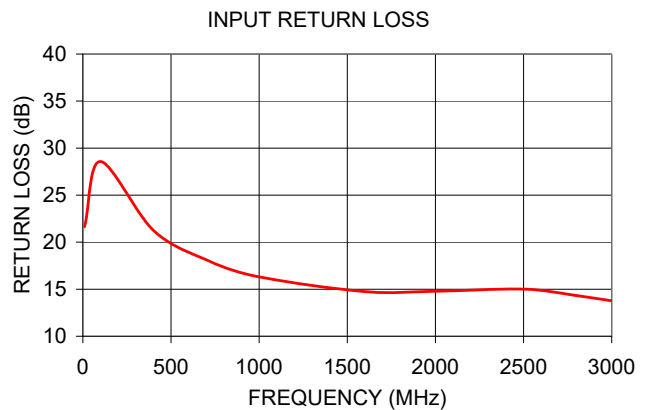

- NOTES**
- A. Performance and quality attributes and conditions not expressly stated in this specification document are intended to be excluded and do not form a part of this specification document.
 - B. Electrical specifications and performance data contained in this specification document are based on Mini-Circuit's applicable established test performance criteria and measurement instructions.
 - C. The parts covered by this specification document are subject to Mini-Circuits standard limited warranty and terms and conditions (collectively, "Standard Terms"); Purchasers of this part are entitled to the rights and benefits contained therein. For a full statement of the standard. Terms and the exclusive rights and remedies thereunder, please visit Mini-Circuits' website at www.minicircuits.com/terms/viewterm.html

