

Coaxial Low Pass Filter

VLFG-1325+

50Ω DC to 1325 MHz



Generic photo used for illustration purposes only
CASE STYLE: FF704

The Big Deal

- Excellent power handling, 5.5W
- Temperature stable
- Rugged unibody construction
- Good rejection, 48 dB typical

Product Overview

VLFG-1325+ is a 50Ω low pass filter built in rugged unibody construction. Covering DC-1325 MHz bandwidth, these units offer good matching within the passband and good rejection in stopband. VLFG-1325+ offer low insertion loss, and excellent power handling capability. It handles up to 5.5W RF input power and provides a wide operating temperature range from -55°C to 125°C.

Key Features

Feature	Advantages
Low passband insertion loss	Suitable for high performance application.
5.5W Power handling	Supports a range of system power requirements.
Connectorized package	The connectorized package is easy to interface with other devices and well suited for test setups.

Notes

- A. Performance and quality attributes and conditions not expressly stated in this specification document are intended to be excluded and do not form a part of this specification document.
B. Electrical specifications and performance data contained in this specification document are based on Mini-Circuit's applicable established test performance criteria and measurement instructions.
C. The parts covered by this specification document are subject to Mini-Circuits standard limited warranty and terms and conditions (collectively, "Standard Terms"); Purchasers of this part are entitled to the rights and benefits contained therein. For a full statement of the Standard Terms and the exclusive rights and remedies thereunder, please visit Mini-Circuits' website at www.minicircuits.com/MCLStore/terms.jsp



Low Pass Filter

VLFG-1325+

50Ω DC to 1325 MHz



Generic photo used for illustration purposes only
CASE STYLE: FF704

+RoHS Compliant

The +Suffix identifies RoHS Compliance. See our web site for RoHS Compliance methodologies and qualifications

Features

- Low loss, 1.1dB typ.
- High rejection 48dB typ.
- Excellent power handling, 5.5W
- Temperature stable
- Connectorized package
- Rugged unibody construction

Applications

- Military radio applications
- Test and measurement
- Telecommunications and broadband wireless applications

Electrical Specifications at 25°C

Parameter		F#	Frequency (MHz)	Min.	Typ.	Max.	Unit
Pass Band	Insertion Loss	DC-F1	DC - 1325	—	1.1	1.8	dB
	Freq. Cut-Off	F2*	1550	—	3.0	—	dB
	Return Loss	DC-F1	DC - 1325	—	21	—	dB
Stop Band	Rejection Loss	F3-F4	1900 - 2150	20	40	—	dB
		F4-F5	2150 - 6500	37	48	—	dB
		F5-F6	6500 - 11600	—	28	—	dB

In Application where DC voltage is present at either input or output port, DC blocks are required.

* Typically, a ±5% frequency deviation from the stated value may occur on a unit-to-unit basis.

Functional Schematic

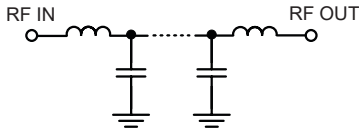

Maximum Ratings

Operating Temperature	-55°C to 125°C
Storage Temperature	-55°C to 125°C
RF Power Input*	5.5W max. @25°C

*Passband rating, derate linearly to 1W at 125°C ambient

Permanent damage may occur if any of these limits are exceeded.

Typical Performance Data at 25°C

Frequency (MHz)	Insertion Loss (dB)	Return Loss (dB)
10	0.06	42.51
100	0.13	33.57
300	0.24	29.96
500	0.32	28.42
700	0.42	26.42
900	0.54	25.94
1000	0.61	26.52
1325	1.07	30.75
1550	3.12	10.00
1655	9.99	2.97
1730	19.96	1.54
1790	30.84	1.15
1900	44.15	0.84
2150	61.68	0.56
3000	50.97	0.38
5000	62.66	0.41
6500	48.47	0.42
8000	39.89	0.42
10000	31.38	0.54
11600	27.52	0.98

Typical Frequency Response

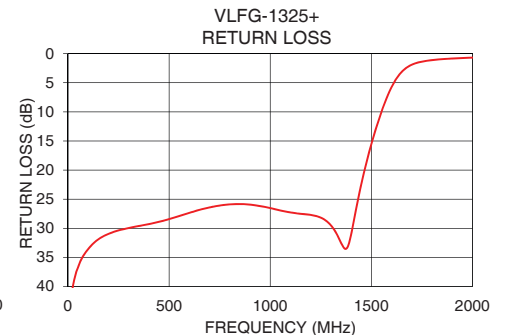
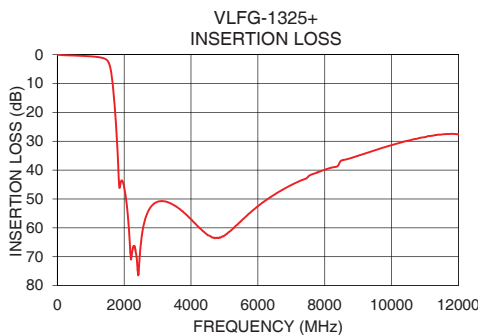
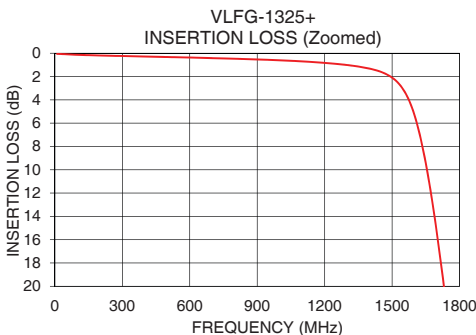
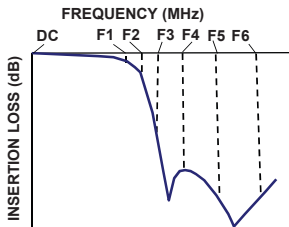

Notes

- Performance and quality attributes and conditions not expressly stated in this specification document are intended to be excluded and do not form a part of this specification document.
- Electrical specifications and performance data contained in this specification document are based on Mini-Circuits' applicable established test performance criteria and measurement instructions.
- The parts covered by this specification document are subject to Mini-Circuits standard limited warranty and terms and conditions (collectively, "Standard Terms"); Purchasers of this part are entitled to the rights and benefits contained therein. For a full statement of the Standard Terms and the exclusive rights and remedies thereunder, please visit Mini-Circuits' website at www.minicircuits.com/MCLStore/terms.jsp



Coaxial Connections

PORT - 1	SMA-Male
PORT - 2	SMA-Female

Outline Drawing

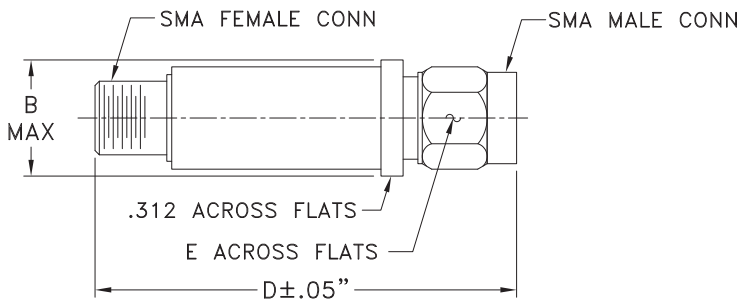

Outline Dimensions (inch)

B	D	E	wt.
.410	1.43	.312	grams
10.41	36.32	7.92	10

Note: Please refer to case style drawing for details

Notes

- A. Performance and quality attributes and conditions not expressly stated in this specification document are intended to be excluded and do not form a part of this specification document.
- B. Electrical specifications and performance data contained in this specification document are based on Mini-Circuit's applicable established test performance criteria and measurement instructions.
- C. The parts covered by this specification document are subject to Mini-Circuits standard limited warranty and terms and conditions (collectively, "Standard Terms"); Purchasers of this part are entitled to the rights and benefits contained therein. For a full statement of the Standard Terms and the exclusive rights and remedies thereunder, please visit Mini-Circuits' website at www.minicircuits.com/MCLStore/terms.jsp

