

Directional Coupler

Z30-18-4-75

75Ω 5 to 1000 MHz



CASE STYLE: K18

Connectors Model
BNC Z30-18-4-75+

Maximum Ratings

Operating Temperature -55°C to 100°C

Storage Temperature -55°C to 100°C

* Case temperature is defined as temperature on ground leads.
Permanent damage may occur if any of these limits are exceeded.

Coaxial Connections

INPUT	1
OUTPUT	2
COUPLED	3

Features

- very flat coupling
- very broad, multi-octave
- all welded construction
- protected by U.S Patents 6,140,887 & 6,784,521

Applications

- VHF/UHF
- instrumentation
- cable tv
- cellular

Electrical Specifications (T_{AMB} = -55°C to 100°C)

FREQ. (MHz)	COUPLING (dB)		MAINLINE LOSS ¹ (dB)						DIRECTIVITY (dB)						VSWR (:1)	POWER INPUT, W		
	Nom.	Typ. Flatness	L		M		U		L		M		U			Typ.	L	MU
f _L -f _U			Typ.	Max.	Typ.	Max.	Typ.	Max.	Typ.	Min.	Typ.	Min.	Typ.	Min.	Typ.	Max.	Max.	
5-1000	18.5±0.5	±0.5	0.8	1.5	0.85	1.5	0.95	1.6	28	17	23	16	15	—	1.30	1.0	1.0	

L = low range [f_L to 10 f_L] M = mid range [10 f_L to f_U/2] U = upper range [f_U/2 to f_U]

1. Mainline loss includes theoretical power loss at coupled port.

Outline Drawing

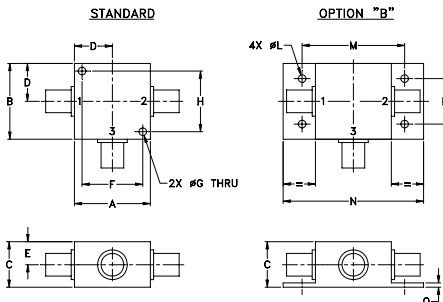

Outline Dimensions (inch/mm)

A	B	C	D	E	F	G	H
1.25	1.25	.75	.63	.38	1.00	.125	1.000
31.75	31.75	19.05	16.00	9.65	25.40	3.18	25.40

J	K	L	M	N	P	Q	wt
--	--	.125	1.688	2.18	.75	.07	grams
--	--	3.18	42.88	55.37	19.05	1.78	70.0

Typical Performance Data

Frequency (MHz)	Mainline Loss (dB) In-Out	Coupling (dB) In-Cpl	Directivity (dB)	Return Loss (dB)		
				In	Out	Cpl
5.00	0.88	18.17	26.83	20.12	22.09	19.91
50.00	0.80	18.05	27.94	21.82	24.52	21.60
150.00	0.81	18.07	28.42	21.72	24.14	19.39
300.00	0.74	18.07	28.32	20.92	23.17	15.85
400.00	0.81	18.19	26.64	21.03	24.11	14.06
550.00	0.94	18.42	23.47	18.77	21.14	11.77
675.00	0.98	18.54	20.98	17.59	18.69	10.33
800.00	0.97	18.59	18.90	17.21	18.90	9.51
925.00	0.99	18.73	16.98	17.06	17.80	8.84
1000.00	1.00	18.84	16.02	16.74	16.72	8.45

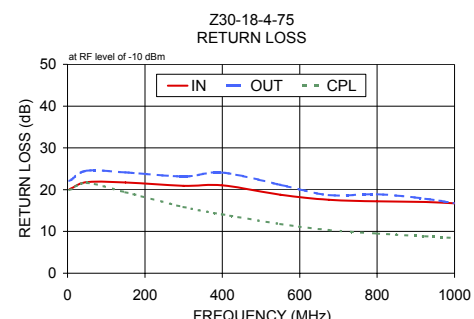
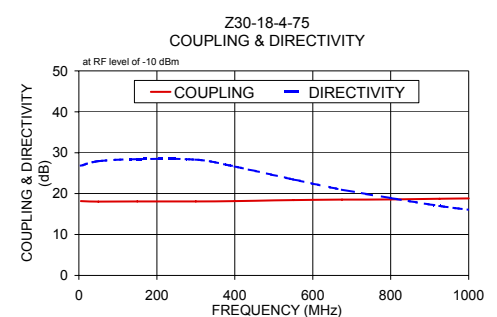
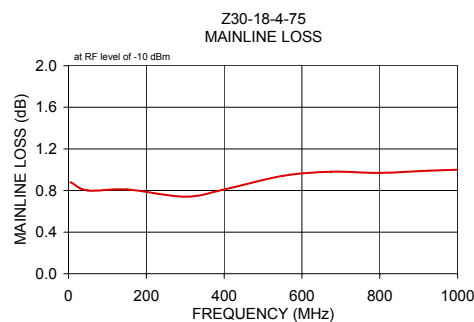

Electrical Schematic

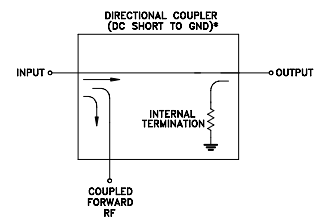

* ELECTRICAL SCHEMATIC IS FOR DIRECTIONAL COUPLER WITH INTERNAL TRANSFORMERS THAT ROUTES DC FROM RF PORTS TO GROUND.

Notes

- Performance and quality attributes and conditions not expressly stated in this specification document are intended to be excluded and do not form a part of this specification document.
- Electrical specifications and performance data contained in this specification document are based on Mini-Circuit's applicable established test performance criteria and measurement instructions.
- The parts covered by this specification document are subject to Mini-Circuits standard limited warranty and terms and conditions (collectively, "Standard Terms"); Purchasers of this part are entitled to the rights and benefits contained therein. For a full statement of the Standard Terms and the exclusive rights and remedies thereunder, please visit Mini-Circuits' website at www.minicircuits.com/WCLStore/terms.jsp

