

DC Pass, High Power

# Power Splitter/Combiner ZC6PD-18263-S+

6 Way-0° 50Ω 18000 to 26500 MHz

## The Big Deal

- Super wideband, 18 to 26.5 GHz
- Low insertion loss, 1.1 dB typ.
- High Isolation, 24 dB typ.
- 20W power handling
- Low amplitude unbalance, 0.28 dB typ.



CASE STYLE: UU2414-1

## Product Overview

Mini-Circuits' ZC6PD-18263-S+ is a super wideband 6-way 0° splitter/combiner providing coverage from 18 to 26.5 GHz, supporting a wide range of applications including 5G, K-Band, Ka-Band, instrumentation and many more. This model provides 20W power handling as a splitter and very low insertion loss across the entire operating frequency range, minimizing power dissipation and delivering excellent signal power transmission from input to output. The ZC6PD-18263-S+ comes housed in a case measuring 1.8 x 3.5 x 0.5".

## Key Features

Feature	Advantages
Ultra-wideband, 18 to 26.5 GHz	Extremely wide frequency range supports many broadband applications in a single model. Ideal for use in wideband instrumentation
Low insertion loss, 1.1 dB typ. at 22 GHz	The combination of 20W power handling and low insertion loss makes this model a suitable candidate for distributing signals while maintaining excellent transmission of signal power.
High isolation, 24 dB typ. at 22 GHz	Minimizes interference between ports.
High power handling: <ul style="list-style-type: none"><li>• 20W as a splitter at 25°C</li><li>• 1.68W as a combiner</li></ul>	The ZC6PD-18263-S+ is suitable for systems with a wide range of power requirements.
Low amplitude unbalance, 0.28 dB at 22 GHz	Produces nearly equal output signals, ideal for parallel path and multichannel systems.
DC Passing, 404mA	Supports applications where DC power is needed to pass through the RF line.

### Notes

- A. Performance and quality attributes and conditions not expressly stated in this specification document are intended to be excluded and do not form a part of this specification document.  
B. Electrical specifications and performance data contained in this specification document are based on Mini-Circuit's applicable established test performance criteria and measurement instructions.  
C. The parts covered by this specification document are subject to Mini-Circuits standard limited warranty and terms and conditions (collectively, "Standard Terms"); Purchasers of this part are entitled to the rights and benefits contained therein. For a full statement of the Standard Terms and the exclusive rights and remedies thereunder, please visit Mini-Circuits' website at [www.minicircuits.com/MCLStore/terms.jsp](http://www.minicircuits.com/MCLStore/terms.jsp)



# Power Splitter/Combiner

## ZC6PD-18263-S+

6 Way-0° 50Ω 18000 to 26500 MHz

### Maximum Ratings

Operating Temperature	-55°C to 100°C
Storage Temperature	-55°C to 100°C
Power Input (as a splitter)	20W* max.
Internal Dissipation	1.68W max.
DC Current	404 mA

Permanent damage may occur if any of these limits are exceeded.  
\* Derate linearly to 8.2W at 100°C

### Coaxial Connections

SUM PORT	S
PORT 1,2,3,4,5,6	1,2,3,4,5,6

### Outline Drawing

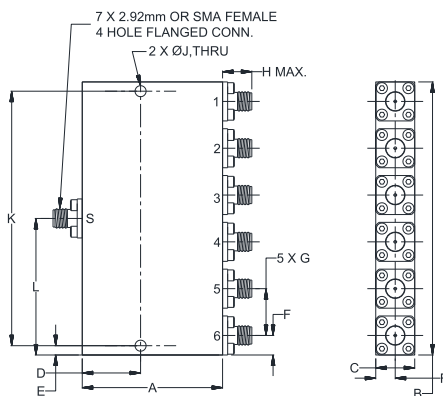

### Outline Dimensions (inch/mm)

A	B	C	D	E	F
1.80	3.50	.50	.748	.119	.25
45.72	88.90	12.70	19.00	3.02	6.35
G	H	J	K	L	wt
.60	.43	.142	3.262	1.75	grams
15.24	11	3.6	82.85	44.45	180

### Electrical Schematic

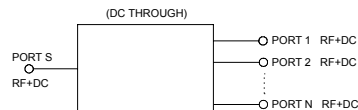

### Features

- wideband, 18000 to 26500 MHz
- low insertion loss, 1.1 dB typ.
- low amplitude unbalance, 0.28 dB typ.
- low phase unbalance, 5.2 deg. typ.
- high isolation, 24 dB typ.
- DC Pass from sum port to all output ports

### Applications

- 5G
- fixed satellite
- space research
- mobile



Generic photo used for illustration purposes only

CASE STYLE: UU2414-1

Connectors	Model
SMA-Fem	ZC6PD-18263-S+

**+RoHS Compliant**  
The +Suffix identifies RoHS Compliance. See our web site for RoHS Compliance methodologies and qualifications

### Electrical Specifications at 25°C

Parameter	Frequency (MHz)	Min.	Typ.	Max.	Unit
<b>Frequency Range</b>		18000		26500	MHz
<b>Insertion Loss (above theoretical 7.8 dB)</b>	18000-26500		1.1	1.9	dB
<b>Isolation</b>	18000-26500	18	24		dB
<b>Phase Unbalance (±)¹</b>	18000-26500		5.2	8	Degree
<b>Amplitude Unbalance (±)¹</b>	18000-26500		0.28	0.5	dB
<b>VSWR (Port S)</b>	18000-26500		1.23	1.5	:1
<b>VSWR Output (Port 1-6)</b>	18000-26500		1.36	1.6	:1

1. With reference to average.

### Typical Performance Data

Frequency (MHz)	Total Loss¹ (dB)			Amplitude Unbalance (dB)	Isolation (dB)			Phase Unbal. (deg.)	VSWR S	VSWR 1	VSWR 3
	S-1	S-3	S-5		1-2	1-3	1-6				
18000	8.58	8.52	8.56	0.23	22.36	40.46	31.36	2.75	1.15	1.16	1.16
18500	8.51	8.45	8.65	0.20	27.99	28.33	31.23	2.50	1.09	1.06	1.11
19000	8.58	8.53	8.69	0.20	26.06	26.03	31.89	2.58	1.05	1.09	1.10
19500	8.61	8.56	8.72	0.18	22.11	29.21	32.83	2.79	1.21	1.05	1.09
20000	8.62	8.57	8.66	0.12	32.12	37.53	33.34	2.60	1.04	1.10	1.08
20500	8.65	8.60	8.64	0.13	26.05	26.35	34.58	2.47	1.15	1.17	1.16
21000	8.63	8.58	8.75	0.17	25.18	26.20	36.02	2.35	1.09	1.13	1.12
21500	8.64	8.60	8.76	0.19	33.86	32.58	37.18	2.23	1.10	1.20	1.21
22000	8.61	8.57	8.79	0.26	30.97	30.12	38.17	2.37	1.08	1.18	1.19
22500	8.68	8.65	8.81	0.26	28.85	27.45	40.19	2.70	1.13	1.17	1.16
23000	8.62	8.58	8.83	0.25	30.34	26.46	40.14	3.01	1.08	1.19	1.18
23500	8.73	8.69	8.90	0.22	34.75	30.99	38.65	2.99	1.12	1.24	1.24
24000	8.65	8.62	8.87	0.25	27.80	31.06	37.99	3.35	1.07	1.13	1.14
25000	8.74	8.73	8.85	0.19	29.14	34.41	35.52	4.29	1.06	1.11	1.15
26500	8.79	8.75	8.96	0.26	25.58	32.52	34.36	6.41	1.09	1.17	1.19

1. Total Loss = Insertion Loss + 7.8dB splitter loss.

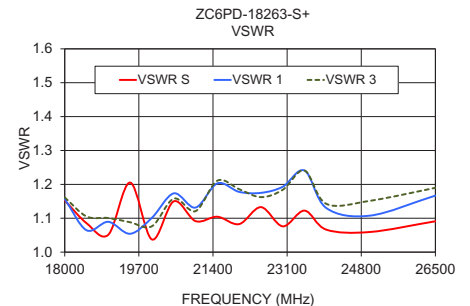
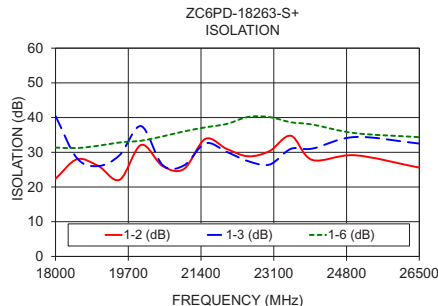
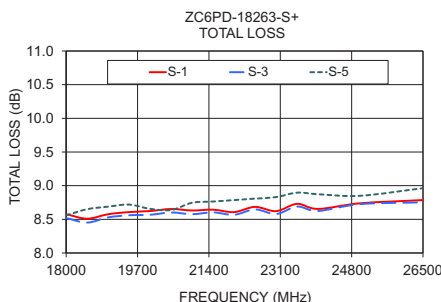

#### Notes

- Performance and quality attributes and conditions not expressly stated in this specification document are intended to be excluded and do not form a part of this specification document.
- Electrical specifications and performance data contained in this specification document are based on Mini-Circuit's applicable established test performance criteria and measurement instructions.
- The parts covered by this specification document are subject to Mini-Circuit's standard limited warranty and terms and conditions (collectively, "Standard Terms"); Purchasers of this part are entitled to the rights and benefits contained therein. For a full statement of the Standard Terms and the exclusive rights and remedies thereunder, please visit Mini-Circuit's website at [www.minicircuits.com/MCLStore/terms.jsp](http://www.minicircuits.com/MCLStore/terms.jsp)

