

Wideband, DC Pass

Directional Coupler

ZCDC20-V18443+

50Ω 20dB Up to 16W 18 to 44 GHz

The Big Deal

- Wideband, 18 to 44 GHz
- Excellent Coupling Flatness, ± 0.4 dB typ.
- Power Handling up to 16W



CASE STYLE: HT2536-3

Product Overview

The Mini-Circuits' ZCDC20-V18443+ wideband directional coupler offers exceptional performance operating over 18 to 44 GHz. This coupler has excellent coupling flatness, good directivity, and power handling. It is ideal for lab testing applications as well as for power monitoring over wide bands, among other applications.

Key Features

Feature	Advantages
Wide bandwidth	With a bandwidth spanning 18 to 44 GHz, ZCDC20-V18443+ coupler is ideal for most lab testing applications, avoiding the need to switch components for different frequency bands.
Excellent Directivity • 18 dB typ. up to 44 GHz	High directivity allows sampling of input powers with minimal detrimental effects due to output mismatches.
Excellent coupling flatness, ± 0.4 dB typ	Excellent coupling flatness over the entire frequency range minimizes the need for compensation circuits in most cases.
Good Return Loss (In & Out) • 16 dB typ. up to 44 GHz	Good return loss over 18 to 44 GHz minimizes undesired reflections and resulting amplitude ripple.

Notes

- A. Performance and quality attributes and conditions not expressly stated in this specification document are intended to be excluded and do not form a part of this specification document.
B. Electrical specifications and performance data contained in this specification document are based on Mini-Circuit's applicable established test performance criteria and measurement instructions.
C. The parts covered by this specification document are subject to Mini-Circuits standard limited warranty and terms and conditions (collectively, "Standard Terms"); Purchasers of this part are entitled to the rights and benefits contained therein. For a full statement of the Standard Terms and the exclusive rights and remedies thereunder, please visit Mini-Circuits' website at www.minicircuits.com/MCLStore/terms.jsp



Wideband, DC Pass Directional Coupler

ZCDC20-V18443+

50Ω 20dB Up to 16W 18 to 44 GHz



Generic photo used for illustration purposes only

CASE STYLE: HT2536-3

Connectors	Model
2.4mm Female	ZCDC20-V18443+

+RoHS Compliant

The +Suffix identifies RoHS Compliance. See our web site for RoHS Compliance methodologies and qualifications

Maximum Ratings

Operating Temperature	-55°C to 100°C
Storage Temperature	-55°C to 100°C
Supplied Termination*	1 W
DC Current	0.422 A

Permanent damage may occur if any of these limits are exceeded
* up to 25°C, derates linearly to 325mW at 100°C.

Coaxial Connections

INPUT	IN
OUTPUT	OUT
COUPLED	CPL
TERMINATION (50Ω) INCLUDED	—

Outline Drawing

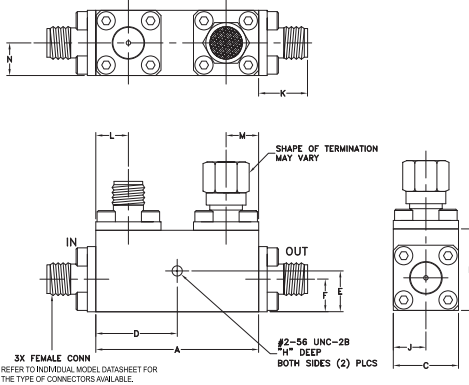

Outline Dimensions (inch/mm)

A	B	C	D	E	F	G
1.25	0.63	0.50	6.25	0.313	0.25	--
31.75	16.00	12.70	158.75	7.95	6.35	--
H	J	K	L	M	N	wt
0.120	0.25	0.43	0.25	0.25	0.25	grams
3.05	6.35	11	6.35	6.35	6.35	50

Electrical Schematic

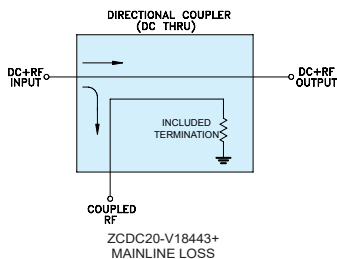

Features

- Wide frequency range, 18 to 44 GHz
- Good coupling flatness, ±0.4 dB typ.
- Good directivity, 18 dB typ. up to 44 GHz
- Good return loss, 16 dB typ. up to 44 GHz
- DC current pass through input to output

Applications

- 5G
- Mobile
- Fixed satellite
- Lab use

Electrical Specifications at 25°C

Parameter	Frequency (GHz)	Min.	Typ.	Max.	Units
Operating Frequency		18		44	GHz
Nominal Coupling	18-44		20±1.2		dB
Coupling Flatness (±)	18-44		0.4	0.7	dB
Mainline Loss ¹	18-26.5		0.6	0.9	dB
	26.5-44		0.7	1.4	dB
Directivity	18-26.5	13.0	24.1		dB
	26.5-44	10.0	21.6		dB
Return Loss (In & Out)	18-26.5	12.7	24.9		dB
	26.5-44	11.7	24.5		dB
Return Loss (Coupling)	18-26.5	12.7	23.5		dB
	26.5-44	11.7	22.9		dB
Input Power ²				16	W

1. Mainline loss includes coupling loss
2. Up to 25°C, derates linearly to 8.9W at 100°C.

Typical Performance Data

Frequency (MHz)	Mainline Loss ¹ (dB) In-Out	Coupling (dB) In-Cpl	Directivity (dB)	Return Loss (dB)		
				In	Out	Cpl
18000	0.5	19.7	30.6	23.8	24.5	23.0
20000	0.5	19.9	22.7	30.9	29.8	22.1
24000	0.6	19.9	26.2	32.0	35.1	32.2
26000	0.6	20.0	28.1	19.6	19.6	20.2
28000	0.7	20.1	23.4	21.4	20.9	24.5
30000	0.6	20.1	20.2	26.2	26.7	23.8
34000	0.7	20.2	25.3	22.0	21.3	23.2
38000	0.8	20.2	18.7	25.3	26.8	16.4
42000	0.9	20.5	19.9	18.4	18.5	21.6
44000	0.9	20.4	29.0	16.6	16.7	20.9

1. Mainline loss includes coupling loss

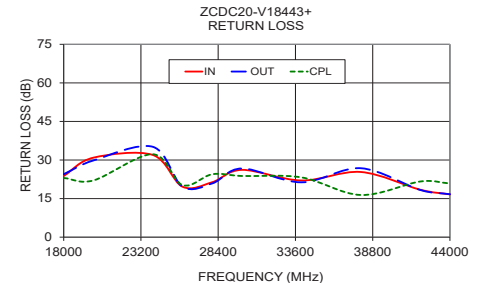
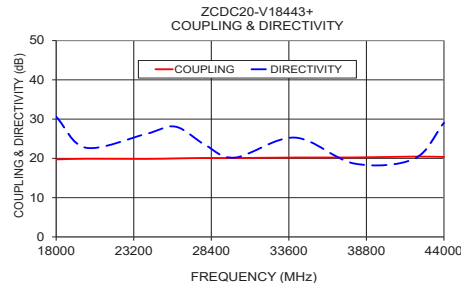
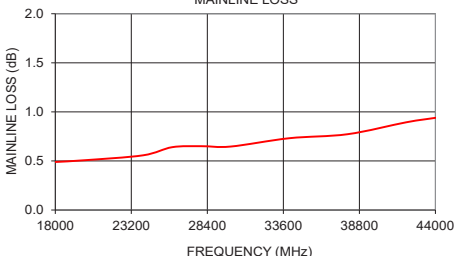

Notes

- Performance and quality attributes and conditions not expressly stated in this specification document are intended to be excluded and do not form a part of this specification document.
- Electrical specifications and performance data contained in this specification document are based on Mini-Circuit's applicable established test performance criteria and measurement instructions.
- The parts covered by this specification document are subject to Mini-Circuit's standard limited warranty and terms and conditions (collectively, "Standard Terms"); Purchasers of this part are entitled to the rights and benefits contained therein. For a full statement of the Standard Terms and the exclusive rights and remedies thereunder, please visit Mini-Circuit's website at www.minicircuits.com/MCLStore/terms.jsp



www.minicircuits.com P.O. Box 350166, Brooklyn, NY 11235-0003 (718) 934-4500 sales@minicircuits.com

REV. OR
ECO-006864
ZCDC20-V18443+
JM/CP/PS
210312
Page 2 of 2