

Coaxial Directional Coupler

ZFDC-15-5

50Ω

1 to 2000 MHz



BNC version shown
CASE STYLE: K18

Connectors	Model
BNC	ZFDC-15-5
SMA	ZFDC-15-5-S
N-TYPE	ZFDC-15-5-N
BRACKET (OPTION "B")	

Maximum Ratings

Operating Temperature	-55°C to 100°C
Storage Temperature	-55°C to 100°C
Permanent damage may occur if any of these limits are exceeded.	

Coaxial Connections

INPUT	3
OUTPUT	1
COUPLED	2

Features

- very wideband, 1 to 2000 MHz
- excellent directivity, 25 dB typ.
- rugged shielded case

Applications

- cellular
- instrumentation
- communications receivers & transmitters
- GPS

Directional Coupler Electrical Specifications

FREQ. RANGE (MHz)	COUPLING (dB)		MAINLINE LOSS ¹ (dB)				DIRECTIVITY (dB)			VSWR (:1)	POWER INPUT (W)						
	Nom.	Flatness	L		M		U		Typ.		Min.	Typ.	Max.	MU			
			Typ.	Max.	Typ.	Max.	Typ.	Max.									
1-2000	15.5±0.5	±1.0	1.2	1.8	1.2	1.8	1.3	2.3	30	20	25	20	18	11	1.3	0.5	2.0

L = low range [f_L to $10 f_L$] M = mid range [$10 f_L$ to $f_U/2$] U = upper range [$f_U/2$ to f_U]
1. Mainline loss includes theoretical power loss at coupled port.

Outline Drawing

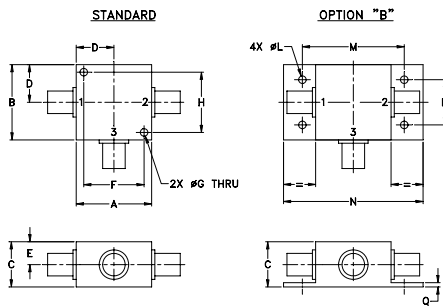

Outline Dimensions (inch/mm)

A	B	C	D	E	F	G	H
1.25	1.25	.75	.63	.38	1.00	.125	1.000
31.75	31.75	19.05	16.00	9.65	25.40	3.18	25.40
J	K	L	M	N	P	Q	wt
--	--	.125	1.688	2.18	.75	.07	grams
--	--	3.18	42.88	55.37	19.05	1.78	70.0

Typical Performance Data

Frequency (MHz)	Mainline Loss (dB) In-Out	Coupling (dB) In-Cpl	Directivity (dB)	Return Loss (dB)		Cpl
				In	Out	
1.00	1.31	15.29	37.94	15.49	17.00	16.71
5.00	0.92	14.91	34.30	19.27	22.45	21.09
9.00	0.89	14.87	33.82	19.80	23.40	21.66
140.00	0.89	14.89	34.43	19.32	22.11	21.03
320.00	0.94	14.94	39.47	18.32	19.60	20.01
600.00	1.14	15.20	32.43	17.04	17.46	18.10
1100.00	1.18	15.69	21.62	19.09	19.36	16.42
1550.00	1.15	16.06	19.42	22.68	19.74	16.70
1800.00	1.02	16.05	20.39	19.31	17.22	15.67
2000.00	0.91	16.01	22.68	16.81	15.57	13.54

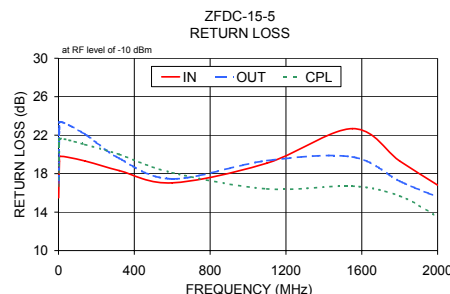
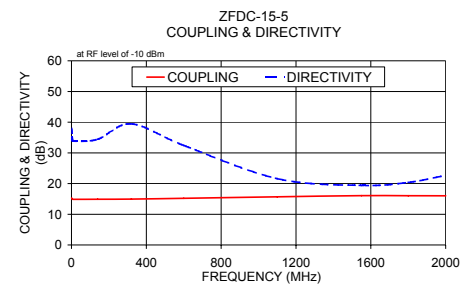
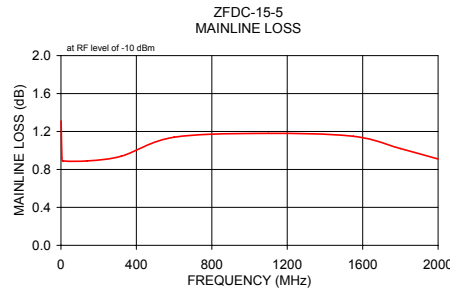

Electrical Schematic

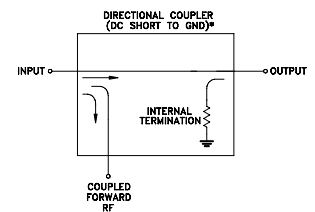

* ELECTRICAL SCHEMATIC IS FOR DIRECTIONAL COUPLER WITH INTERNAL TRANSFORMERS THAT ROUTES DC FROM RF PORTS TO GROUND.

Notes

- Performance and quality attributes and conditions not expressly stated in this specification document are intended to be excluded and do not form a part of this specification document.
- Electrical specifications and performance data contained in this specification document are based on Mini-Circuit's applicable established test performance criteria and measurement instructions.
- The parts covered by this specification document are subject to Mini-Circuits standard limited warranty and terms and conditions (collectively, "Standard Terms"); Purchasers of this part are entitled to the rights and benefits contained therein. For a full statement of the Standard Terms and the exclusive rights and remedies thereunder, please visit Mini-Circuits' website at www.minicircuits.com/WCLStore/terms.jsp



www.minicircuits.com P.O. Box 350166, Brooklyn, NY 11235-0003 (718) 934-4500 sales@minicircuits.com

REV. B
M151107
ZFDC-15-5
WZ/TD/CP/AM
151007