

Power Splitter/Combiner

ZFSC-2-1-75+

2 Way-0° 75Ω 0.25 to 300 MHz



Generic photo used for illustration purposes only
CASE STYLE: K18

Maximum Ratings

Operating Temperature	-55°C to 100°C
Storage Temperature	-55°C to 100°C
Power Input (as a splitter)	1W max.
Internal Dissipation	0.125W max.

Coaxial Connections

SUM PORT	3
PORT 1	1
PORT 2	2

Features

- low insertion loss, 0.4 dB typ.
- high isolation, 30 dB typ.
- excellent amplitude unbalance, 0.1 dB typ.
- excellent phase unbalance, 0.2 deg. typ.
- very good return loss, VSWR, 1.15:1 typ.
- rugged shielded case

Applications

- HF/VHF
- amateur fan radio
- communication systems

Connectors	Model
BNC	ZFSC-2-1-75+
BRACKET (OPTION "B")	

+RoHS Compliant

The +Suffix identifies RoHS Compliance. See our web site for RoHS Compliance methodologies and qualifications

Outline Drawing

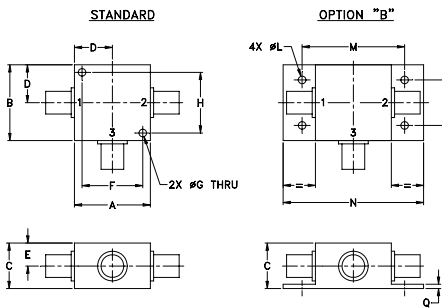

Outline Dimensions (inch/mm)

A	B	C	D	E	F	G	H	
1.25	1.25	.75	.63	.38	1.00	.125	1.000	
31.75	31.75	19.05	16.00	9.65	25.40	3.18	25.40	
J	K	L	M	N	P	Q	wt	
--	--	.125	1.688	2.18	.75	.07	grams	
--	--	3.18	42.88	55.37	19.05	1.78	70.0	

Electrical Specifications

FREQ. RANGE (MHz)	ISOLATION (dB)			INSERTION LOSS (dB) ABOVE 3.0 dB			PHASE UNBALANCE (Degrees)			AMPLITUDE UNBALANCE (dB)		
	L	M	U	L	M	U	L	M	U	L	M	U
f_L - f_U	Typ.	Min.	Typ. Min.	Typ. Max.	Typ. Max.	Typ. Max.	Max.	Max.	Max.	Max.	Max.	Max.
0.25-300	20	15	30 25 25 20	0.4 0.75	0.4 0.75	0.4 1.0	2	3	5	0.15	0.2	0.3

L = low range [f_L to $10 f_L$] M = mid range [$10 f_L$ to $f_U/2$] U = upper range [$f_U/2$ to f_U]

Typical Performance Data

Frequency (MHz)	Total Loss ¹ (dB)		Amplitude Unbalance (dB)	Isolation (dB)	Phase Unbalance (deg.)	VSWR S	VSWR 1	VSWR 2
	S-1	S-2						
0.25	3.23	3.23	0.00	19.70	0.01	1.18	1.49	1.49
1.10	3.20	3.20	0.00	32.56	0.02	1.10	1.17	1.17
1.80	3.18	3.18	0.00	34.82	0.02	1.10	1.15	1.15
2.50	3.17	3.17	0.01	35.51	0.02	1.10	1.14	1.14
6.00	3.15	3.15	0.00	36.11	0.00	1.10	1.12	1.12
9.00	3.17	3.16	0.01	36.18	0.08	1.10	1.12	1.11
38.00	3.19	3.18	0.01	35.33	0.06	1.10	1.11	1.11
94.00	3.21	3.21	0.01	32.50	0.01	1.10	1.12	1.12
150.00	3.22	3.23	0.01	29.91	0.12	1.12	1.12	1.12
194.00	3.25	3.26	0.01	28.27	0.12	1.12	1.13	1.13
238.00	3.24	3.26	0.02	26.88	0.18	1.13	1.15	1.14
270.00	3.26	3.29	0.02	26.03	0.10	1.14	1.15	1.15
280.00	3.25	3.29	0.03	25.76	0.07	1.14	1.15	1.15
290.00	3.25	3.29	0.04	25.53	0.14	1.14	1.15	1.15
300.00	3.27	3.31	0.04	25.30	0.12	1.14	1.16	1.16

1. Total Loss = Insertion Loss + 3dB splitter loss.

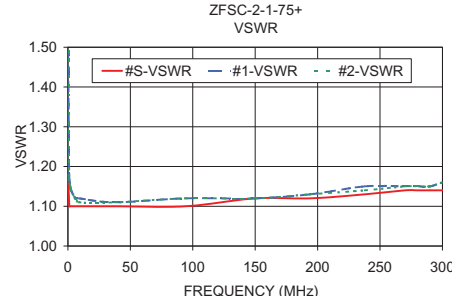
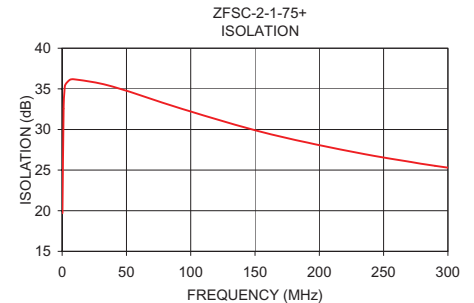
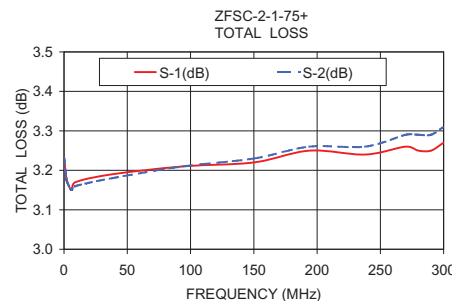

electrical schematic



Notes

- Performance and quality attributes and conditions not expressly stated in this specification document are intended to be excluded and do not form a part of this specification document.
- Electrical specifications and performance data contained in this specification document are based on Mini-Circuit's applicable established test performance criteria and measurement instructions.
- The parts covered by this specification document are subject to Mini-Circuit's standard limited warranty and terms and conditions collectively, "Standard Terms"; Purchasers of this part are entitled to the rights and benefits contained therein. For a full statement of the Standard Terms and the exclusive rights and remedies thereunder, please visit Mini-Circuit's website at www.minicircuits.com/MCLStore/terms.jsp

