

Coaxial

# Power Splitter/Combiner

## ZFSCJ-2-4+

2 Way-180° 50Ω 50 to 1000 MHz



CASE STYLE: K18

Connectors Model  
**SMA ZFSCJ-2-4-S+**  
**BRACKET (OPTION "B")**

**+RoHS Compliant**  
 The +Suffix identifies RoHS Compliance. See our web site for RoHS Compliance methodologies and qualifications

### Maximum Ratings

Operating Temperature	-55°C to 100°C
Storage Temperature	-55°C to 100°C
Power Input (as a splitter)	1W max.
Internal Dissipation	0.125W max.
Permanent damage may occur if any of these limits are exceeded.	

### Coaxial Connections

SUM PORT	3
PORT 1	1
PORT 2	2

### Outline Drawing

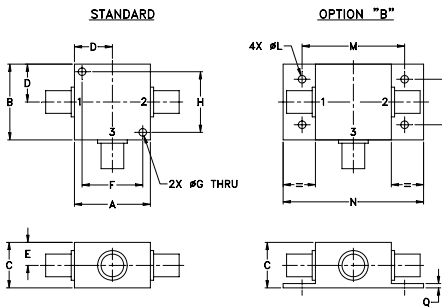

### Outline Dimensions (inch/mm)

A	B	C	D	E	F	G	H
1.25	1.25	.75	.63	.38	1.00	.125	1.000
31.75	31.75	19.05	16.00	9.65	25.40	3.18	25.40
J	K	L	M	N	P	Q	wt
--	--	.125	1.688	2.18	.75	.07	grams
--	--	3.18	42.88	55.37	19.05	1.78	70.0

### Features

- low insertion loss, 1.4 dB typ.
- high isolation, 28 dB typ.
- rugged shielded case

### Applications

- VHF/UHF
- cellular
- signal processing

### Electrical Specifications

FREQ. RANGE (MHz)	ISOLATION (dB)				INSERTION LOSS (dB) ABOVE 3.0 dB				PHASE UNBALANCE (Degrees)		AMPLITUDE UNBALANCE (dB)	
	L		U		L		U		L	U	L	U
	Typ.	Min.	Typ.	Min.	Typ.	Max.	Typ.	Max.	Max.	Max.	Max.	Max.
f <sub>L</sub> -f <sub>U</sub>												
50-1000	30	20	25	18	1.2	1.9	1.6	2.4	6	7	0.6	0.6

L = low range [f<sub>L</sub> to 10 f<sub>L</sub>] U = upper range [f<sub>U</sub>/2 to f<sub>U</sub>]

### Typical Performance Data

Frequency (MHz)	Total Loss <sup>1</sup> (dB)		Amplitude Unbalance (dB)	Isolation (dB)	Phase Unbalance (deg.)	VSWR S	VSWR 1	VSWR 2
	S-1	S-2						
50.00	3.69	3.71	0.02	35.02	180.77	1.22	1.20	1.27
140.00	3.88	3.86	0.01	31.04	179.44	1.42	1.32	1.47
230.00	4.15	4.16	0.00	28.34	178.79	1.66	1.47	1.72
365.00	4.46	4.43	0.03	25.57	177.86	1.95	1.66	2.07
500.00	4.64	4.63	0.01	23.95	177.94	2.10	1.77	2.30
560.00	4.78	4.73	0.05	23.39	177.67	2.09	1.78	2.35
620.00	4.78	4.70	0.08	22.87	178.11	2.04	1.78	2.36
680.00	4.79	4.72	0.07	22.42	178.17	1.96	1.75	2.34
720.00	4.64	4.53	0.11	22.11	178.53	1.89	1.72	2.31
750.00	4.55	4.42	0.13	21.69	178.68	1.83	1.70	2.28
780.00	4.85	4.73	0.12	21.93	178.61	1.76	1.66	2.25
840.00	4.48	4.29	0.19	21.17	179.47	1.61	1.59	2.16
920.00	4.47	4.30	0.17	20.99	180.61	1.42	1.49	2.05
960.00	4.60	4.36	0.23	21.04	180.29	1.33	1.44	1.99
1000.00	4.59	4.46	0.13	21.07	178.64	1.25	1.39	1.95

1. Total Loss = Insertion Loss + 3dB splitter loss.

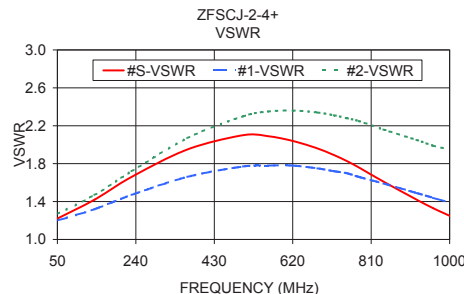
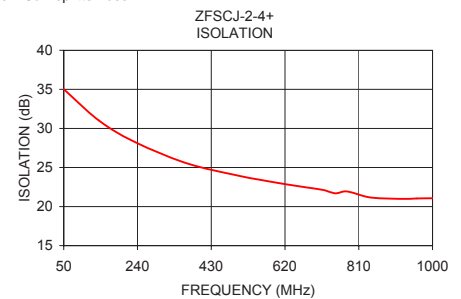
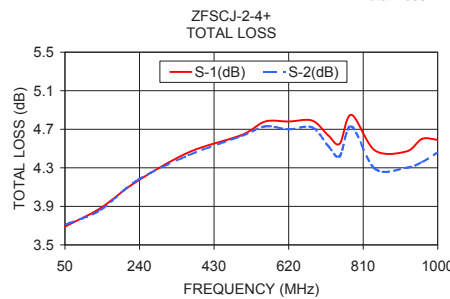

### Electrical Schematic

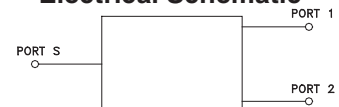

### Notes

- Performance and quality attributes and conditions not expressly stated in this specification document are intended to be excluded and do not form a part of this specification document.
- Electrical specifications and performance data contained in this specification document are based on Mini-Circuit's applicable established test performance criteria and measurement instructions.
- The parts covered by this specification document are subject to Mini-Circuit's standard limited warranty and terms and conditions (collectively, "Standard Terms"); Purchasers of this part are entitled to the rights and benefits contained therein. For a full statement of the Standard Terms and the exclusive rights and remedies thereunder, please visit Mini-Circuit's website at [www.minicircuits.com/MCLStore/terms.jsp](http://www.minicircuits.com/MCLStore/terms.jsp)

