

Coaxial Frequency Mixer

Level 23 (LO Power +23 dBm) 10 to 2400 MHz

ZFY-11



Generic photo used for illustration purposes only

CASE STYLE: K18

Connectors	Model
BNC	ZFY-11
SMA	ZFY-11-S
BRACKET (OPTION "B")	

Maximum Ratings

Operating Temperature	-55°C to 100°C
Storage Temperature	-55°C to 100°C
RF Power	350mW
IF Current	40mA

Permanent damage may occur if any of these limits are exceeded.

Coaxial Connections

LO	1
RF	2
IF	3

Features

- low conversion loss, 7.40 dB typ.
- wideband, 10 to 2400 MHz
- rugged shielded case

Applications

- UHF/VHF
- cellular
- satellite distribution
- GPS
- PCS/DCS

Outline Drawing

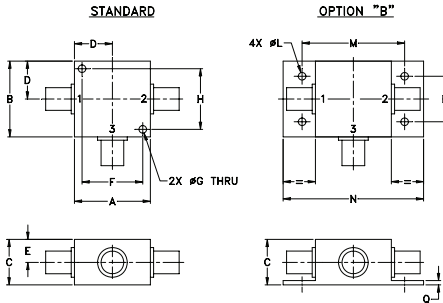

Outline Dimensions (inch/mm)

A	B	C	D	E	F	G	H	
1.25	1.25	.75	.63	.38	1.00	.125	1.000	
31.75	31.75	19.05	16.00	9.65	25.40	3.18	25.40	
J	K	L	M	N	P	Q	wt	
--	--	.125	1.688	2.18	.75	.07	grams	
--	--	3.18	42.88	55.37	19.05	1.78	70.0	

Electrical Specifications

FREQUENCY (MHz)		CONVERSION LOSS (dB)				LO-RF ISOLATION (dB)						LO-IF ISOLATION (dB)					
LO/RF	IF	Mid-Band		Total Range	Max.	L		M		U		L		M		U	
f_L - f_U	\bar{X}	σ	Max.			Typ.	Min.	Typ.	Min.	Typ.	Min.	Typ.	Min.	Typ.	Min.	Typ.	Min.
10-2400	5-1000	7.40	0.09	8.5	10	28	20	25	20	25	20	28	20	26	20	25	20

1 dB COMP.: +20 dBm typ.

L = low range [f_L to $10 f_L$] M = mid range [$10 f_L$ to $f_U/2$] U = upper range [$f_U/2$ to f_U]
m = mid band [$2f_L$ to $f_U/2$]

Typical Performance Data

Frequency (MHz)		Conversion Loss (dB)	Isolation L-R (dB)	Isolation L-I (dB)	VSWR RF Port (:1)	VSWR LO Port (:1)
RF	LO	LO +23dBm	LO +23dBm	LO +23dBm	LO +23dBm	LO +23dBm
10.00	40.00	7.46	41.65	30.72	1.55	1.24
20.00	50.00	7.51	43.95	31.06	1.54	1.22
50.00	80.00	7.74	44.45	30.74	1.51	1.31
87.10	57.10	7.81	44.86	29.91	1.50	1.26
100.00	70.00	7.66	44.68	29.62	1.49	1.25
200.00	170.00	7.59	46.21	28.67	1.47	1.22
318.39	288.39	8.03	41.22	28.91	1.45	1.23
500.00	470.00	7.47	37.07	29.62	1.43	1.28
626.77	596.77	7.57	33.53	30.05	1.38	1.34
780.97	750.97	7.27	33.54	31.66	1.34	1.29
1000.00	970.00	7.77	33.08	33.53	1.38	1.23
1089.36	1059.36	7.84	33.62	34.45	1.49	1.33
1243.54	1213.54	8.04	34.16	36.92	1.59	1.35
1397.74	1367.74	8.31	33.51	37.46	1.82	1.48
1500.00	1470.00	8.18	34.49	39.38	1.99	1.58
1706.13	1676.13	8.31	34.41	45.70	2.18	1.69
2000.00	1970.00	8.17	37.07	38.82	2.32	1.71
2091.61	2061.61	8.07	37.89	36.35	2.32	1.68
2245.81	2215.81	7.59	37.54	34.57	2.28	1.74
2400.00	2370.00	7.11	35.91	33.44	2.15	1.77

Electrical Schematic

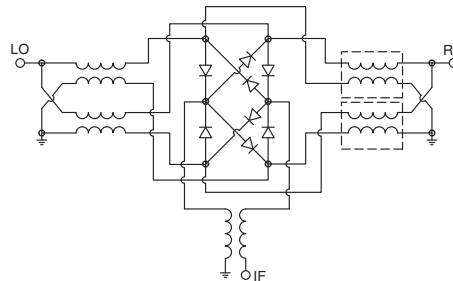

Notes

- Performance and quality attributes and conditions not expressly stated in this specification document are intended to be excluded and do not form a part of this specification document.
- Electrical specifications and performance data contained in this specification document are based on Mini-Circuit's applicable established test performance criteria and measurement instructions.
- The parts covered by this specification document are subject to Mini-Circuits standard limited warranty and terms and conditions (collectively, "Standard Terms"); Purchasers of this part are entitled to the rights and benefits contained therein. For a full statement of the Standard Terms and the exclusive rights and remedies thereunder, please visit Mini-Circuits' website at www.minicircuits.com/WCLStore/terms.jsp



www.minicircuits.com P.O. Box 350166, Brooklyn, NY 11235-0003 (718) 934-4500 sales@minicircuits.com

REV A
M151107
ZFY-11
DJ/TD/CP
200811

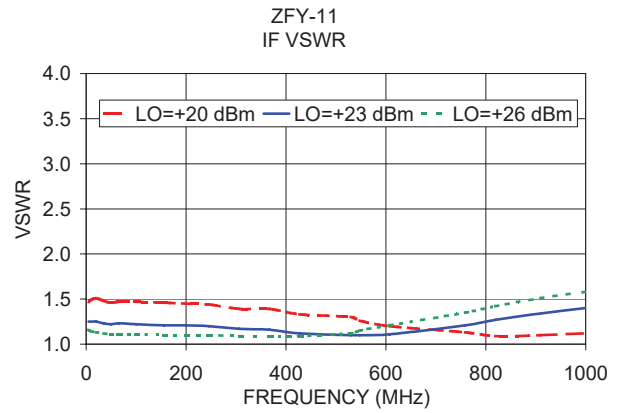
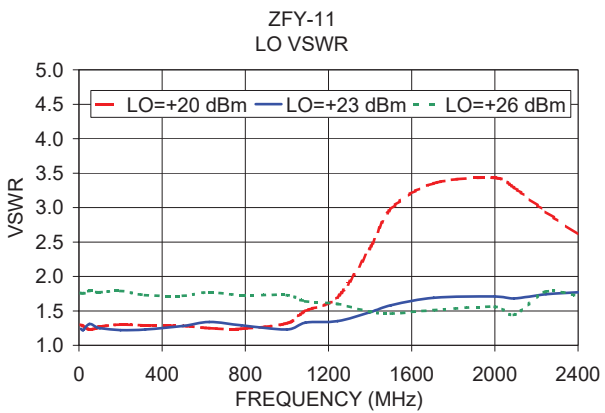
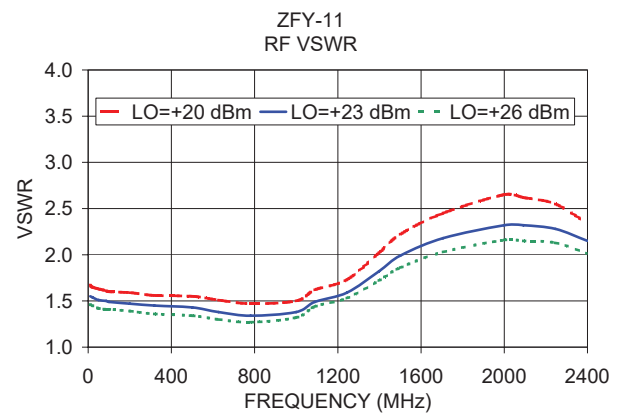
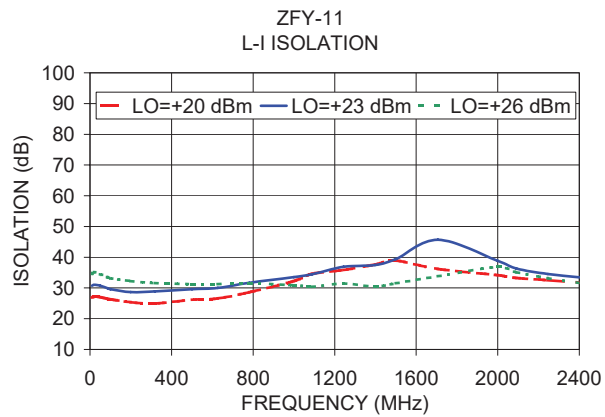
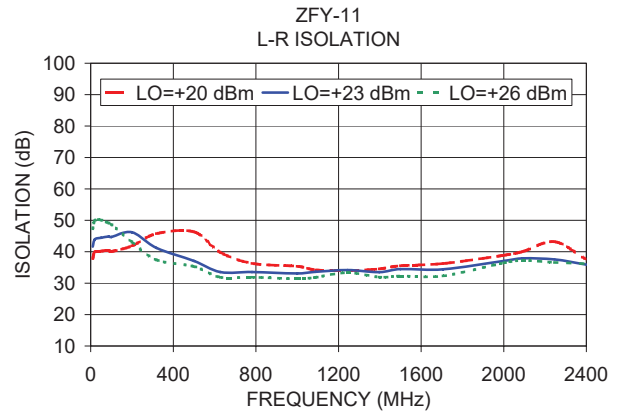
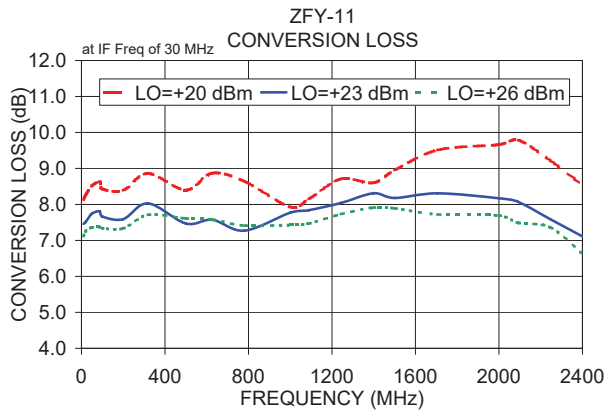

Notes

- A. Performance and quality attributes and conditions not expressly stated in this specification document are intended to be excluded and do not form a part of this specification document.
- B. Electrical specifications and performance data contained in this specification document are based on Mini-Circuit's applicable established test performance criteria and measurement instructions.
- C. The parts covered by this specification document are subject to Mini-Circuits standard limited warranty and terms and conditions (collectively, "Standard Terms"); Purchasers of this part are entitled to the rights and benefits contained therein. For a full statement of the Standard Terms and the exclusive rights and remedies thereunder, please visit Mini-Circuits' website at www.minicircuits.com/MCLStore/terms.jsp

