

6dB DC Pass

High Power Directional Coupler

ZGDC6-521-N+

50Ω 6dB 130 to 520 MHz

The Big Deal

- High Power Handling: 60W
- Low Insertion Loss: 0.2 dB typ.*



CASE STYLE: HT3025

Product Overview

The Mini-Circuits ZGDC6-521-N+ broadband high power directional coupler offers excellent performance across a wide range of popular frequency bands. The ZGDC6-521-N+ can pass up to 1A of DC current from input to output and handle up to 60W CW. The rugged construction makes this coupler ideal for use in field applications or remote monitoring sites. It is also ideal for high power lab testing.

Key Features

Feature	Advantages
Excellent Insertion Loss , 0.2 dB Typ*	With extremely low insertion loss, this coupler is ideal for critical high power applications.
Ultra High Return Loss, 28 dB Typ	Outstanding Return loss makes this coupler ideal for sensitive power measurement and other signal distribution applications.
High Power Handling, 60W	Up to 60W CW power handling, combined with low insertion loss and excellent VSWR support operation in high power applications such as transmitters, base stations and high power device characterization.
Excellent Directivity and Coupling Flatness	Typical 26 dB directivity and ± 0.6 dB of Coupling flatness provides accurate signal sampling of forward or reflected power.
Passes DC Current, 1A	Capable of passing 1A current, input to output; this coupler is suited for application using remote antenna control or other remote motorized requirements.

*Does not include coupling loss

Notes

- Performance and quality attributes and conditions not expressly stated in this specification document are intended to be excluded and do not form a part of this specification document.
- Electrical specifications and performance data contained in this specification document are based on Mini-Circuit's applicable established test performance criteria and measurement instructions.
- The parts covered by this specification document are subject to Mini-Circuits standard limited warranty and terms and conditions (collectively, "Standard Terms"); Purchasers of this part are entitled to the rights and benefits contained therein. For a full statement of the Standard Terms and the exclusive rights and remedies thereunder, please visit Mini-Circuits' website at www.minicircuits.com/MCLStore/terms.jsp



6dB DC Pass

High Power Directional Coupler

ZGDC6-521-N+

50Ω Up to 60W 130 to 520 MHz

Maximum Ratings

Operating Temperature	-55°C to 100°C
Storage Temperature	-55°C to 100°C
DC Current	1A
Supplied Termination	30W

Permanent damage may occur if any of these limits are exceeded

Coaxial Connections

INPUT	IN
OUTPUT	OUT
COUPLED	CPL
TERMINATION (50Ω), INTERNAL	TERM

Features

- good coupling flatness, ±0.6 dB typ.
- high directivity, 26 dB typ.
- very good VSWR, 1.08:1 typ.
- high power, up to 60W
- DC current pass through input to output

Applications

- lab use
- VHF and UHF
- Defense



Generic photo used for illustration purposes only

CASE STYLE: HT3025

Connectors	Model
N-Type	ZGDC6-521-N+

+RoHS Compliant

The +Suffix identifies RoHS Compliance. See our web site for RoHS Compliance methodologies and qualifications

Outline Drawing

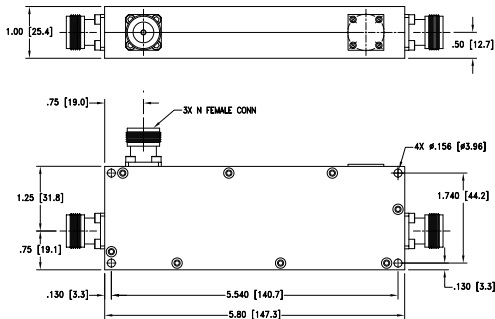

Electrical Specifications at 25°C

Parameter	Frequency (MHz)	Min.	Typ.	Max.	Units
Operating Frequency		130		520	MHz
Coupling	130-520	-	6±1.0	-	dB
Coupling Flatness	130-520	-	±0.6	±1.0	dB
Mainline Loss ¹	130-520	-	0.2	0.6	dB
Directivity	130-520	18	26	-	dB
Return Loss (In & Out)	130-520	17.6	28	-	dB
Return Loss (Coupling)	130-520	17.6	31	-	dB
Input Power ²	130-520	-	-	60	W

1. Does not include coupling loss.
2. At 25°C with no DC current. Derate linearly to 5W at 100°C.

Electrical Schematic

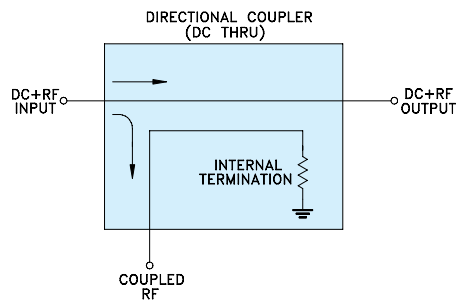

Notes

- Performance and quality attributes and conditions not expressly stated in this specification document are intended to be excluded and do not form a part of this specification document.
- Electrical specifications and performance data contained in this specification document are based on Mini-Circuit's applicable established test performance criteria and measurement instructions.
- The parts covered by this specification document are subject to Mini-Circuit's standard limited warranty and terms and conditions (collectively, "Standard Terms"); Purchasers of this part are entitled to the rights and benefits contained therein. For a full statement of the Standard Terms and the exclusive rights and remedies thereunder, please visit Mini-Circuit's website at www.minicircuits.com/MCLStore/terms.jsp



Typical Performance

Frequency (MHz)	Mainline Loss ⁽¹⁾ (dB)		Coupling (dB) In-Cpl	Directivity (dB)	Return Loss (dB)		
	In-Out				In	Out	Cpl
130	0.13		6.39	27.19	27.63	27.33	26.56
160	0.15		5.84	27.02	27.51	27.34	26.44
200	0.17		5.71	26.41	27.38	27.51	26.66
240	0.18		6.06	25.63	27.17	27.49	27.03
280	0.20		6.61	25.03	27.14	27.39	27.89
320	0.21		6.89	25.04	27.40	27.13	29.31
360	0.22		6.60	25.68	28.26	27.02	30.90
400	0.24		6.06	26.14	29.75	27.25	32.26
440	0.26		5.75	25.92	31.81	27.57	33.03
480	0.28		5.95	24.90	34.73	28.11	34.08
520	0.29		6.91	23.10	39.61	29.22	36.21

1. Does not include coupling loss.

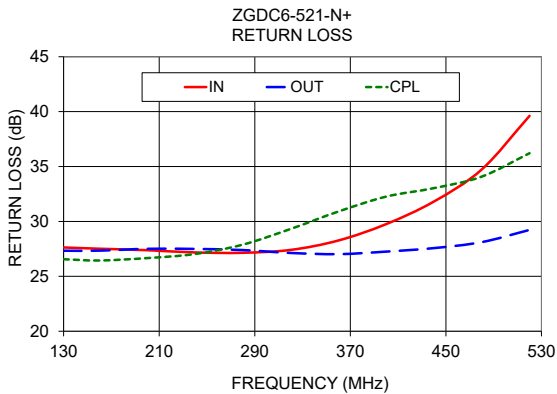
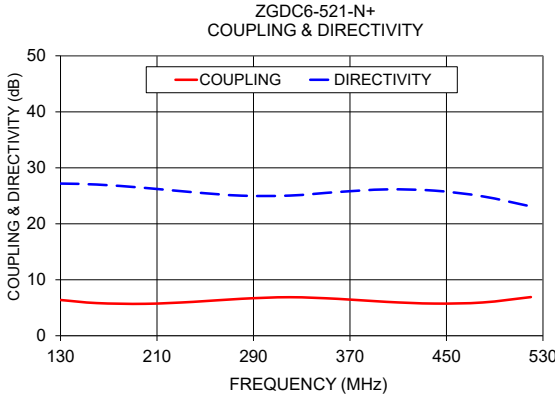
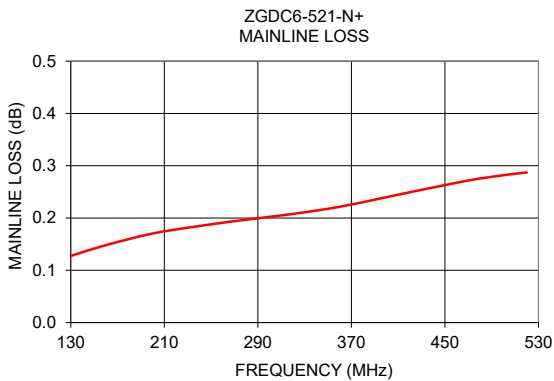

Notes

- A. Performance and quality attributes and conditions not expressly stated in this specification document are intended to be excluded and do not form a part of this specification document.
- B. Electrical specifications and performance data contained in this specification document are based on Mini-Circuit's applicable established test performance criteria and measurement instructions.
- C. The parts covered by this specification document are subject to Mini-Circuits standard limited warranty and terms and conditions (collectively, "Standard Terms"); Purchasers of this part are entitled to the rights and benefits contained therein. For a full statement of the Standard Terms and the exclusive rights and remedies thereunder, please visit Mini-Circuits' website at www.minicircuits.com/MCLStore/terms.jsp

