



COAXIAL

# Medium High Power Amplifier

## ZHL-2W-63-S+ ZHL-2W-63X-S+

Mini-Circuits

50Ω 2W 600 to 6000 MHz

### THE BIG DEAL

- Wideband, 600 to 6000 MHz
- High OIP3, +38 dBm typ.
- High Gain, 42 dB typ.



Generic photo used for illustration purposes only

### APPLICATIONS

- Communication systems
- Cellular
- Instrumentation
- Laboratory

Model No.	ZHL-2W-63-S+	ZHL-2W-63X-S+
Case Style	CP2548-1	
Connectors	SMA	

**+RoHS Compliant**  
 The +Suffix identifies RoHS Compliance.  
 See our website for methodologies and qualifications

### PRODUCT OVERVIEW

Mini-Circuits' ZHL-2W-63-S+ is class AB a medium-power connectorized amplifier with GaN output transistor supporting a wide range of applications from 600 to 6000 MHz, such as test instrumentation, SatCom, and mobile communications systems, including those operating in the new telecom Band 71 allocation (617 to 698 MHz). This model provides +33 dBm output power at saturation. The amplifier operates on a 28V DC supply and comes housed in compact aluminum alloy case (7.00 x 3.25 x 1.12") with SMA connectors, built-in bracket for mounting, and an optional heat sink for efficient cooling.

### KEY FEATURES

Feature	Advantages
Wideband, usable from 500 to 6100 MHz	One amplifier supports a broad range of system and test lab applications. Extended bandwidth down to 600 MHz supports new telecom Band 71 allocation (617 to 698 MHz)
High Gain, 42 dB	Reduces the number of gain stages, lowering component count and overall system cost.
Medium Output Power, +33 dBm	Supports a wide range of power requirements.
High OIP3, +38 dBm	Provides highly linear performance with excellent sensitivity and two-tone spur-free dynamic range.

REV. A  
 ECO-017770  
 ZHL-2W-63-S+  
 MCL NY  
 250407





COAXIAL

# Medium High Power Amplifier

**ZHL-2W-63-S+**  
**ZHL-2W-63X-S+**

Mini-Circuits

50Ω 2W 600 to 6000 MHz

## ELECTRICAL SPECIFICATIONS AT +25°C

Parameter	Condition (MHz)	Min.	Typ.	Max.	Units
Frequency Range		600	–	6000	MHz
Gain	600-6000	34	42	51	dB
Gain Flatness	600-6000	–	±3.5	–	dB
Output Power at 3dB compression	600-6000	–	+31	–	dBm
Output Power at saturation	600-6000	+31	+33	–	dBm
Noise Figure	600-6000	–	12	–	dB
Output third order intercept point	600-6000	–	38	–	dBm
Input VSWR	600-6000	–	2.5	–	:1
Output VSWR	600-6000	–	3.5	–	:1
DC Supply Voltage		–	+28	–	V
Supply Current		–	1.5	2.0	A

Heat sink not included. Alternative heat sinking and heat removal must be provided by the user to limit maximum base-plate temperature to +85°C, in order to ensure proper performance. For reference, this requires thermal resistance of user's external heat sink to be 0.4°C/W max.

## ABSOLUTE MAXIMUM RATINGS

Parameter	Ratings
Operating Temperature	0°C to +60°C
Storage Temperature	-55°C to +100°C
DC Voltage	+32V
Input RF Power (no damage) at load	+7 dBm
Input RF power at OPEN / SHORT	-21 dBm

Permanent damage may occur if any of these limits are exceeded.





COAXIAL

# Medium High Power Amplifier

## ZHL-2W-63-S+ ZHL-2W-63X-S+

Mini-Circuits

50Ω 2W 600 to 6000 MHz

### OUTLINE DRAWING

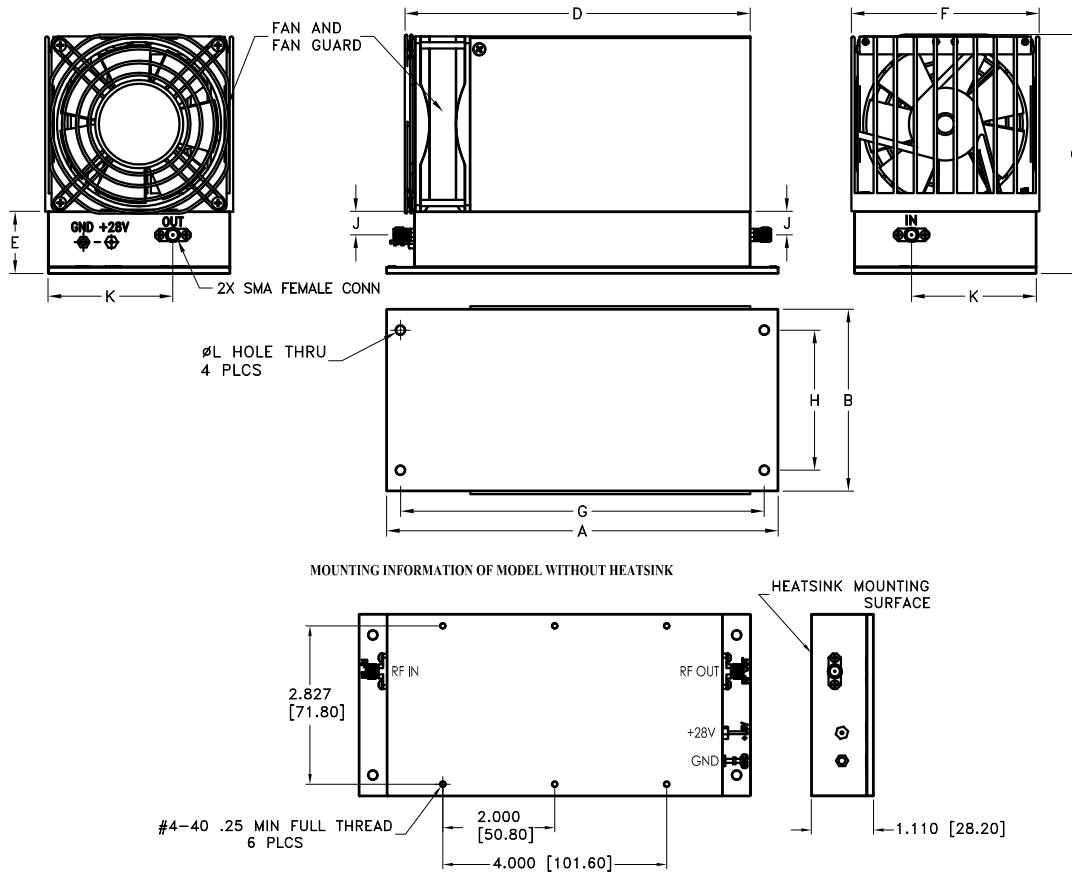

### OUTLINE DIMENSIONS (Inch mm)

A	B	C	D	E	F	G	H	J	K	L	wt
7.00	3.25	4.27	6.17	1.12	3.36	6.50	2.50	0.42	2.23	0.16	grams*
177.8	82.55	108.46	156.72	28.448	85.344	165.1	63.5	10.668	56.642	3.9878	1761

\*600 grams without heatsink



COAXIAL

# Medium High Power Amplifier

## ZHL-2W-63-S+ ZHL-2W-63X-S+

Mini-Circuits

50Ω 2W 600 to 6000 MHz

FREQUENCY (MHz)	GAIN (dB)	DIRECTIVITY (dB)	VSWR (:1)		NOISE FIGURE (dB)	POUT at 3 dB COMPR. (dBm)	POUT at SATURATION (dBm)	OIP3 (dBm)
	28V	28V	IN	OUT				
600	40.54	66.68	2.46	1.78	10.40	34.95	35.69	45.51
1000	40.13	59.78	1.63	1.53	9.67	35.72	36.68	45.45
1500	41.89	49.83	1.68	1.53	9.47	35.74	36.34	46.20
2000	40.55	48.79	1.56	1.83	9.51	34.60	35.95	44.58
2500	44.65	42.29	1.47	1.56	9.60	33.04	35.07	44.36
3000	42.50	43.88	1.65	1.48	9.86	31.41	35.19	43.49
3500	43.90	40.05	1.54	1.44	10.16	33.44	34.89	44.43
4000	41.57	43.62	1.41	1.68	10.48	31.83	33.80	43.84
4500	42.31	42.11	1.41	1.20	10.77	33.09	35.22	43.06
5000	40.48	44.54	1.53	1.49	10.97	30.83	34.04	40.22
5500	40.76	40.47	1.31	1.03	11.23	31.85	34.17	40.55
6000	40.39	43.03	1.11	2.40	11.46	26.87	33.98	36.89

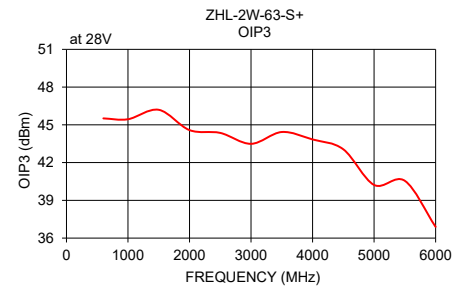
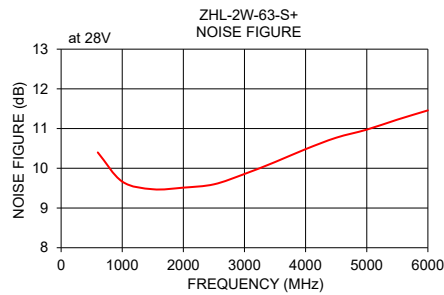
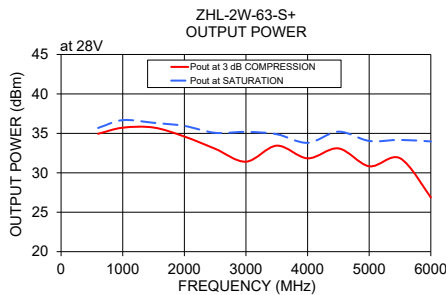
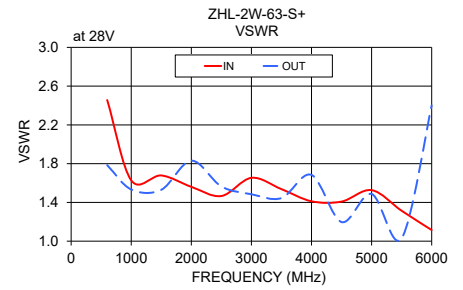
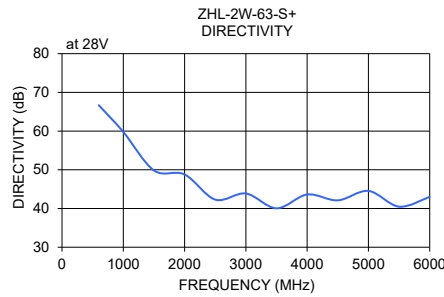
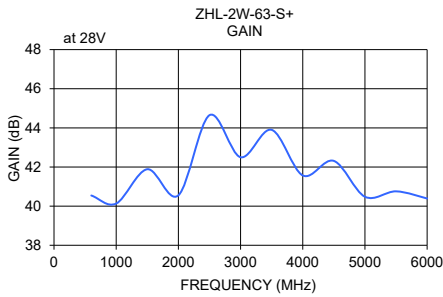

### NOTES

- A. Performance and quality attributes and conditions not expressly stated in this specification document are intended to be excluded and do not form a part of this specification document.
- B. Electrical specifications and performance data contained in this specification document are based on Mini-Circuit's applicable established test performance criteria and measurement instructions.
- C. The parts covered by this specification document are subject to Mini-Circuits standard limited warranty and terms and conditions (collectively, "Standard Terms"); Purchasers of this part are entitled to the rights and benefits contained therein. For a full statement of the standard terms and the exclusive rights and remedies thereunder, please visit Mini-Circuits' website at [www.minicircuits.com/terms/viewterm.html](http://www.minicircuits.com/terms/viewterm.html)

