



COAXIAL

Low Noise Amplifier ZQL-2G22G70W3+

50Ω 2200 to 2700 MHz 0.5 W SMA-Female

KEY FEATURES

- Very Low Noise Figure, 1.1 dB typ.
- High OIP3, +36 dBm typ.
- Rugged, shielded case



Generic photo used for illustration purposes only

APPLICATIONS

- Communication Systems
- R&D, Production, and OTA Test Systems
- Test & Measurement Equipment
- General Laboratory Applications

FUNCTIONAL DIAGRAM

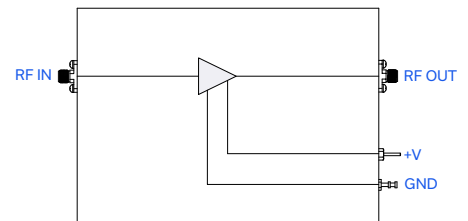

PRODUCT OVERVIEW

The ZQL-2G22G70W3+ is a low-noise amplifier providing about 0.5 W of output power with a typical small signal gain of 34 dB over the 2200 to 2700 MHz frequency band. The amplifier uses state-of-the-art semiconductor technology and can be used in various applications. A single supply voltage ensures ease of operation. The amplifier is made with a rugged aluminum housing.

ELECTRICAL SPECIFICATIONS AT $T_{\text{MOUNTINGBASE}} = +25^{\circ}\text{C}$, $V_{\text{DC}} = +15\text{ V}$

Parameter	Symbol	Condition	Min.	Typ.	Max.	Units
Frequency Range	f		2200		2700	MHz
Small Signal Gain	G_{SS}	$P_{\text{OUT}} = -25\text{ dBm}$	29	34	36	dB
Small Signal Gain Flatness	$G_{\text{SS-FLAT}}$	$P_{\text{OUT}} = -25\text{ dBm}$		± 1.0	± 1.5	dB
Output Power at 1dB compression	$P_{1\text{dB}}$		+22.5	+25.5		dBm
Noise Figure	NF			1.1	1.5	dB
Output Third Order Intercept Point	OIP3	$P_{\text{OUT}} = +10\text{ dBm/tone}$, $\text{df}=1\text{MHz}$	+34	+36		dBm
VSWR	I-VSWR	$P_{\text{OUT}} = -25\text{ dBm}$		1.3:1	1.5:1	-
VSWR	O-VSWR	$P_{\text{OUT}} = -25\text{ dBm}$		1.3:1	1.5:1	-
DC Supply Voltage	V_{DC}		+13	+15	+17	V
Supply Current	I_{DC}			192	340	mA

REV. OR
ECO-022053
ZQL-2G22G70W3+
MCL NY
240611





COAXIAL

Low Noise Amplifier **ZQL-2G22G70W3+**

Mini-Circuits

50Ω 2200 to 2700 MHz 0.5 W SMA-Female

TYPICAL PERFORMANCE DATA AT $T_{\text{MOUNTINGBASE}} = +25^{\circ}\text{C}$, $V_{\text{DC}} = +15\text{ V}$, 50 OHM

Small Signal Gain vs. Frequency

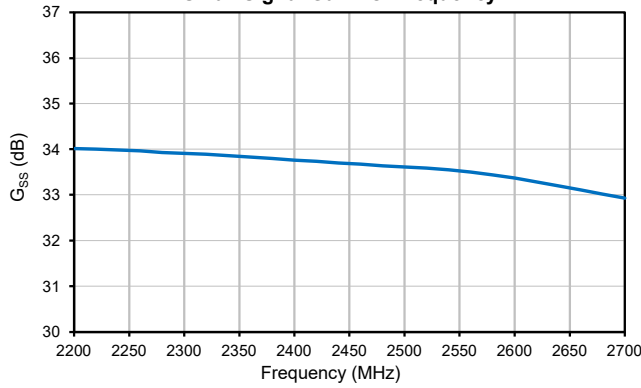

Noise Figure vs. Frequency

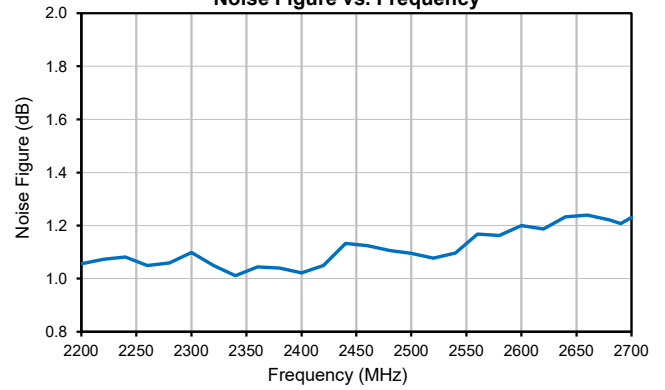

Input VSWR vs. Frequency

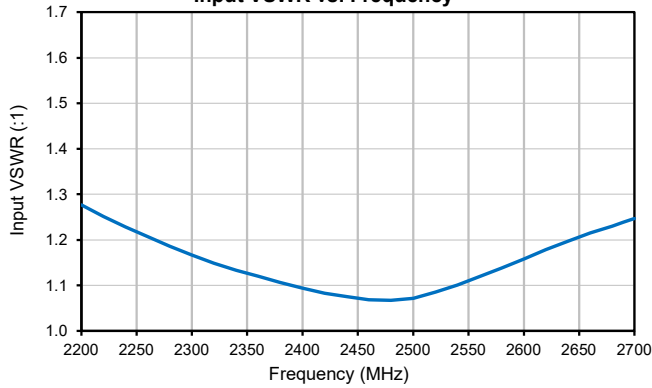

Output VSWR vs. Frequency

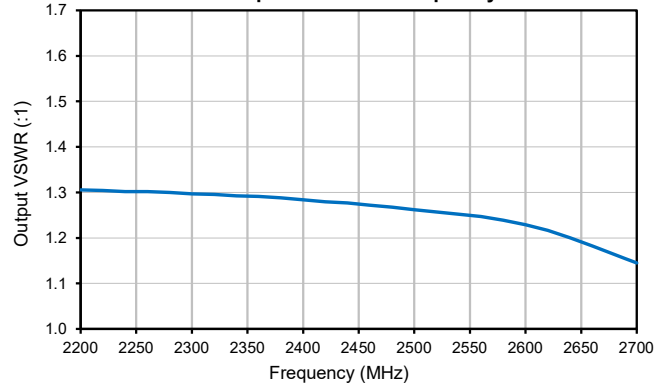

Output Power at 1 dB Compression vs. Frequency

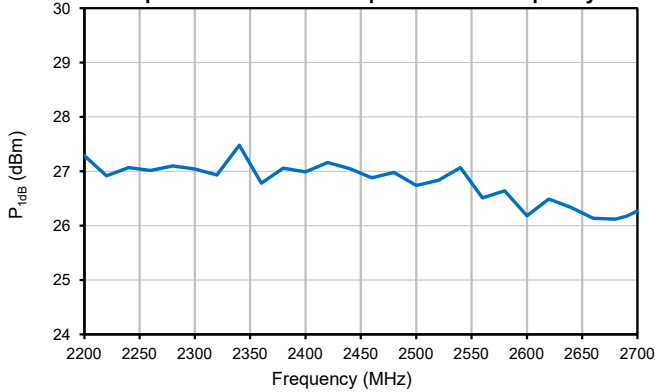

Output Third Order Intercept Point vs. Frequency

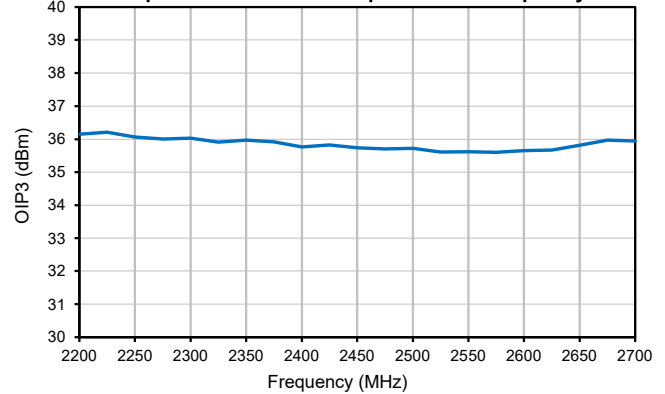



COAXIAL

Low Noise Amplifier **ZQL-2G22G70W3+**

50Ω 2200 to 2700 MHz 0.5 W SMA-Female

ABSOLUTE MAXIMUM RATINGS

Parameter	Ratings
Operating Temperature	T _{AMBIENT} : -40 °C to +70 °C T _{MOUNTINGBASE} : -20 °C to +80 °C
Storage Temperature	-55 °C to +100 °C
No damage with an open or short at P _{OUT} = +25 dBm CW	
RF Input Power (no damage)	+3 dBm with the load connected -12 dBm with no load connected
DC Operating Voltage (Vs)	± 17 V

Permanent damage may occur if any of these limits are exceeded.

DETERMINING MAXIMUM THERMAL RESISTANCE OF USERS' EXTERNAL HEAT SINK

MAXIMUM THERMAL RESISTANCE	$= \frac{\text{MAXIMUM OPERATING CASE TEMP} - \text{MAXIMUM USER AMBIENT TEMP}}{\text{POWER DISSIPATION}}$
Example:	MAXIMUM OPERATING CASE TEMP = +80 °C (CHECK MAXIMUM RATINGS TABLE FOR THIS VALUE) MAXIMUM USER AMBIENT TEMP = +70 °C (USER DEFINED) POWER DISSIPATION = 5.78 WATTS (CHECK MAXIMUM RATINGS TABLE FOR THIS VALUE) THEN MAXIMUM ALLOWABLE THERMAL RESISTANCE = 1.73 °C/W



COAXIAL

Low Noise Amplifier **ZQL-2G22G70W3+**

Mini-Circuits

50Ω 2200 to 2700 MHz 0.5 W SMA-Female

COAXIAL CONNECTIONS

IN (RF IN)	SMA-Female
OUT (RF OUT)	SMA-Female

CASE STYLE DRAWING

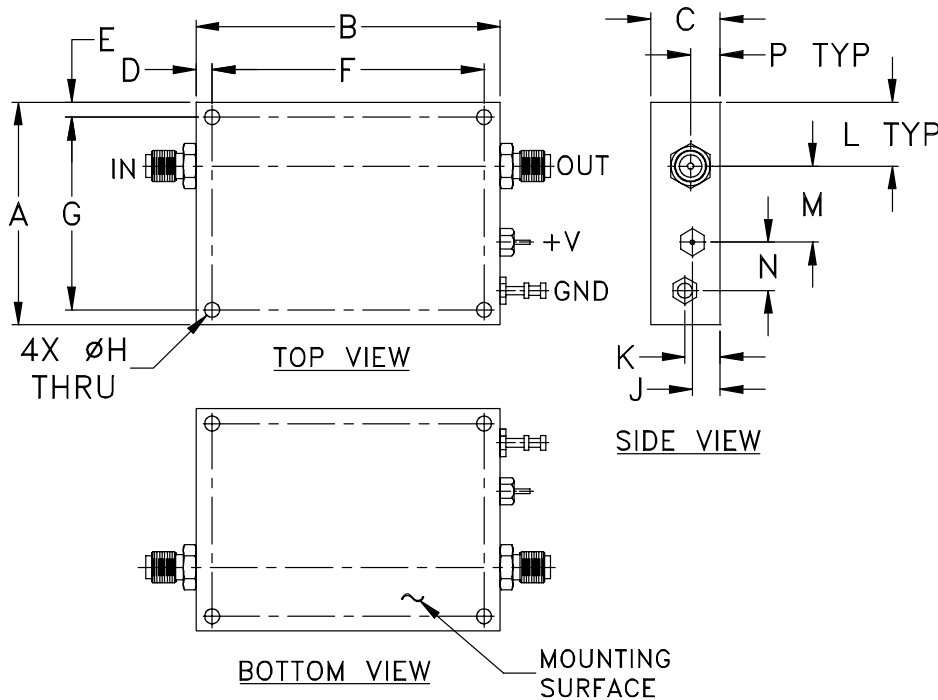

CASE#	A	B	C	D	E	F	G	H	J	K	L	M	N
CW686	1.77 (44.96)	2.42 (61.47)	.55 (13.97)	.13 (3.30)	.12 (3.05)	2.165 (54.99)	1.535 (38.99)	.126 (3.20)	.22 (5.59)	.28 (7.11)	.51 (12.95)	.61 (15.49)	.39 (9.91)

CASE#	P	Q	WT. GRAMS
CW686	.22 (5.59)	--	71

Dimensions are in inches (mm). Tolerances: 2 Pl. ± .03; 3 Pl. ± .015





COAXIAL

Low Noise Amplifier **ZQL-2G22G70W3+**

50Ω 2200 to 2700 MHz 0.5 W SMA-Female

ADDITIONAL INFORMATION IS AVAILABLE ON OUR DASHBOARD.

Performance Data & Graphs	Data
	Graphs
	S-Parameter (S2P Files) Data Set (.zip file)
RoHS Status	Compliant
Environmental Ratings	ENV26

ORDERING INFORMATION

Model No. Links	ZQL-2G22G70W3+
Case Style	CW686
Connector	IN (SMA-Female) / OUT (SMA-Female)

- NOTES**
- A. Performance and quality attributes and conditions not expressly stated in this specification document are intended to be excluded and do not form a part of this specification document.
 - B. Electrical specifications and performance data contained in this specification document are based on Mini-Circuit's applicable established test performance criteria and measurement instructions.
 - C. The parts covered by this specification document are subject to Mini-Circuits standard limited warranty and terms and conditions (collectively, "Standard Terms"); Purchasers of this part are entitled to the rights and benefits contained therein. For a full statement of the standard terms and the exclusive rights and remedies thereunder, please visit Mini-Circuits' website at www.minicircuits.com/terms/viewterm.html

