

**THE BIG DEAL**

- High gain 39 dB typ.
- Good gain flatness, ± 1.5 dB typ.
- Output power 1.5W typ. at saturation
- Low noise figure, 4 dB typ.

APPLICATIONS

- Radar and Military
- Cellular and 5G Sub6
- SATCOM
- WIFI 6E



Generic photo used for illustration purposes only

Model No.	ZVA-1W-103+	ZVA-1W-103X+
Case Style	CP3191	
Connectors	SMA Female	

+RoHS Compliant

The +Suffix identifies RoHS Compliance. See our web site for RoHS Compliance methodologies and qualifications

PRODUCT OVERVIEW

Mini-Circuits' ZVA-1W-103(X)+ is a coaxial, medium power, wideband, high gain amplifier, operating from 500 MHz to 10 GHz. This model operates over a single positive supply of +15 V and delivers an output power of 1.5W (+32 dBm) at saturation, making it an ideal choice for applications requiring a wide-band driver amplifier. With a low noise figure of 4 dB typ. across majority of the band, it can be used in setups that require higher dynamic range. Complementary safety features such as protection against DC transients, over-voltage and reverse voltage conditions ensure that the amplifier stays protected against mishandling.

KEY FEATURES

Feature	Advantages
Wide-band amplifier, 0.5 to 10 GHz	A single amplifier serves the need for applications including Cellular and 5G Sub6 bands (700 to 6 GHz), SATCOM, RADAR and Military.
High Output Power	The model is capable of delivering 1W (+30 dBm) of output power under 1dB compression and more than 1.5W (+32 dBm) of output power under saturation, making it suitable for applications under wide-band test and instrumentation.
<ul style="list-style-type: none"> • High gain • Gain Flatness • Low Noise Figure 	The amplifier provides 39 dB (typ.) of gain with a ± 1.5 dB (typ.) gain flatness, and a low noise figure of 4 dB (typ.). Such features allow weaker signals to be amplified with high fidelity and minimal increase in the noise floor of the system.
DC Protection <ul style="list-style-type: none"> • Over-voltage • Reverse voltage • In-rush Current 	The internal DC circuitry allows the amplifier to be protected from external mishandling, that could lead to catastrophic failures in the field.



ELECTRICAL SPECIFICATIONS AT 25°C BASEPLATE

Parameter	Condition (MHz)	ZVA-1W-103 ³ ZVA-1W-103X ⁴			Units
		Min.	Typ.	Max.	
Frequency Range		500		10000	MHz
Gain	500 - 800	35.0	40.0	—	dB
	800 - 8000	35.0	40.0	—	
	8000 - 10000	33.0	37.0	—	
Gain Flatness	500 - 800	—	±0.5	—	dB
	800 - 8000	—	±1.5	—	
	8000 - 10000	—	±1.5	—	
Output Power at 1dB compression	500 - 800	28.5	30.0	—	dBm
	800 - 8000	29.5	31.5	—	
	8000 - 10000	28.5	30.0	—	
Saturated Output Power	500 - 800	31.5	33.0	—	dBm
	800 - 8000	30.5	32.0	—	
	8000 - 10000	30.0	31.5	—	
Output IP3 (Output Power = +10 dBm/tone)	500 - 800	—	42.0	—	dBm
	800 - 8000	—	40.0	—	
	8000 - 10000	—	38.0	—	
Noise Figure	500 - 800	—	2.7	4.0	dB
	800 - 8000	—	4.0	5.5	
	8000 - 10000	—	5.0	6.0	
Input VSWR	500 - 800	—	1.8	—	:1
	800 - 8000	—	1.4	—	
	8000 - 10000	—	1.5	—	
Output VSWR ¹	500 - 800	—	1.5	—	:1
	800 - 8000	—	1.4	—	
	8000 - 10000	—	1.8	—	
Operating DC Voltage		+14.5	+15	+16	V
Device Operating Current at +15 V			750	1100	mA
Device Operating Power at +15 V			12 ²	15	W

1. Open and short-circuit loads are not recommended at the amplifier output. Ensure proper 50 Ohm load before turning the amplifier "ON".

2. Device operating power based on amplifier under small-signal condition.

3. For units with heatsink, limit ambient temperature to 60 °C.

4. For units without heatsink, limit the maximum baseplate temperature to 75 °C.

MAXIMUM RATINGS⁶

Parameter	Ratings
Operating Temperature	ZVA-1W-103+ -20°C to +60°C Ambient ZVA-1W-103X+ -40°C to +75°C Baseplate
Storage Temperature	-40°C to +85°C
Total Power Dissipation	16W
RF Input Power ⁵ (CW)	+10 dBm
DC Operating Voltage	+16V

5. Specified under matched load to 50 ohms.

6. Continuous operation is not recommended at these extremes.

Permanent damage may occur if any of these limits are exceeded.



MEDIUM POWER, HIGH GAIN

Wideband Amplifier

ZVA-1W-103+ ZVA-1W-103X+

OUTLINE DRAWING

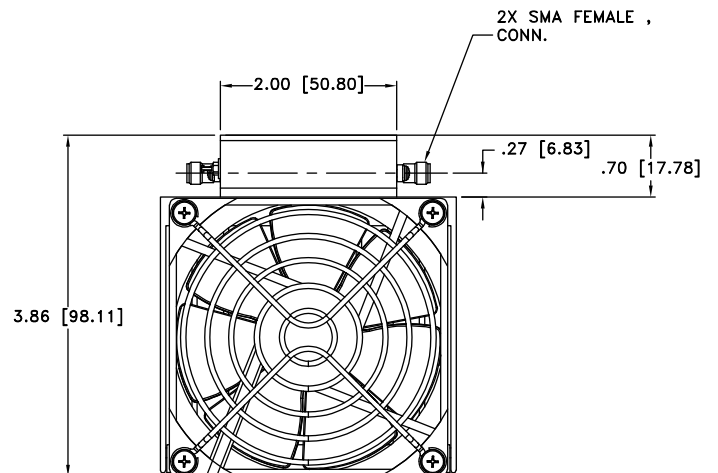
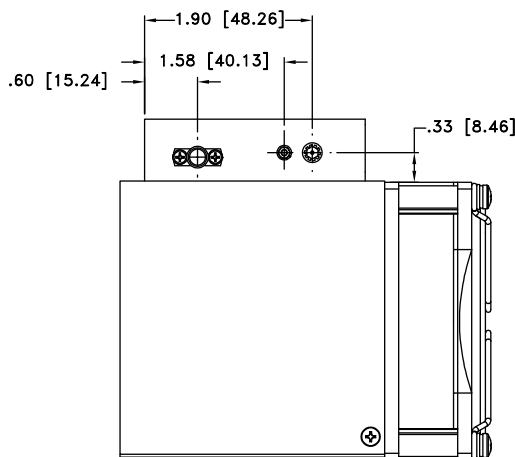
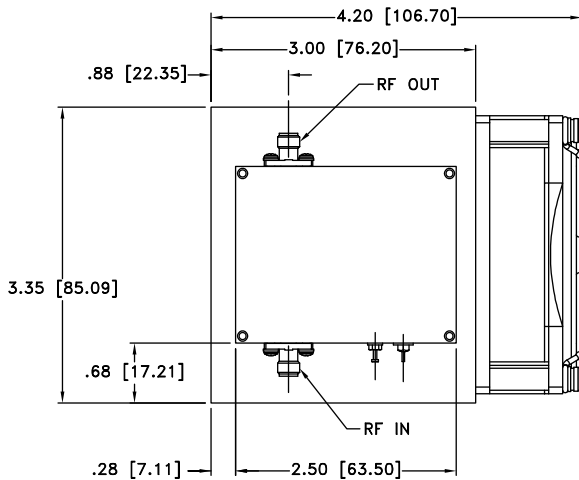

MOUNTING INFORMATION OF MODEL WITHOUT HEATSINK

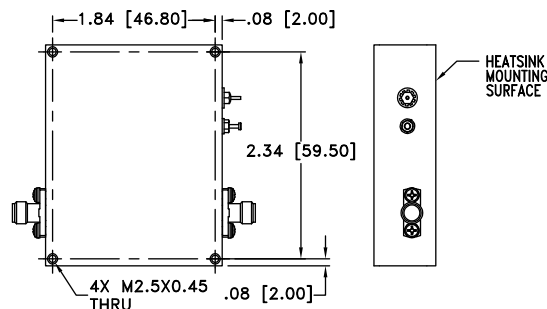

WT. WT. GRAMS 600 grams; WITHOUT HEATSINK GRAMS 160 grams

Dimensions are in inches [mm]. Tolerances: 2 Pl. ±.03; 3 Pl. ±.015





TYPICAL PERFORMANCE DATA/CURVES

Frequency (MHz)	Gain (dB)	Directivity (dB)	VSWR (:1)		POUT at 1 dB Compr. (dBm)	POUT at Saturation (dBm)	Noise Figure (dB)	OIP3 (dBm)
			IN	OUT				
500	38.22	49.36	2.10	1.44	30.01	32.86	2.63	40.71
800	39.99	43.55	1.73	1.34	30.72	33.54	2.64	41.47
1000	40.62	60.78	1.63	1.25	30.79	33.85	2.73	41.92
2000	40.39	52.12	1.32	1.45	31.58	33.57	3.15	40.75
3000	39.49	53.60	1.19	1.31	32.06	33.56	3.75	40.65
4000	38.96	49.59	1.10	1.18	32.59	33.58	4.13	41.07
5000	39.65	60.63	1.22	1.16	32.54	33.40	4.08	40.66
6000	39.16	55.13	1.26	1.29	31.83	32.68	4.01	39.60
7000	39.03	48.65	1.51	1.54	31.66	32.47	4.10	39.14
8000	38.31	47.72	1.46	1.69	30.62	31.98	4.16	37.76
9000	38.80	60.60	1.32	1.68	30.36	31.66	4.66	37.37
10000	35.78	61.27	1.90	1.71	30.58	31.81	5.23	37.21

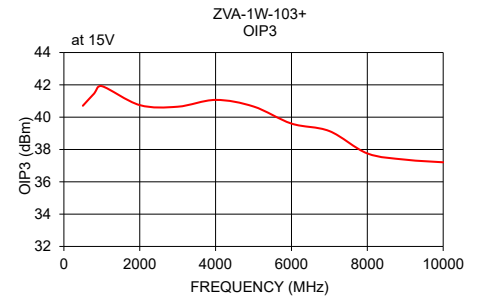
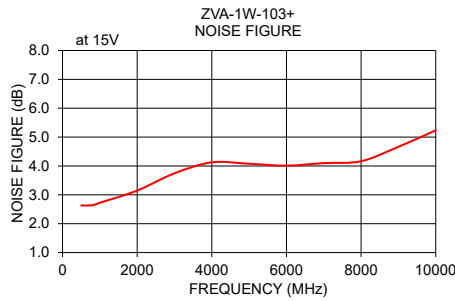
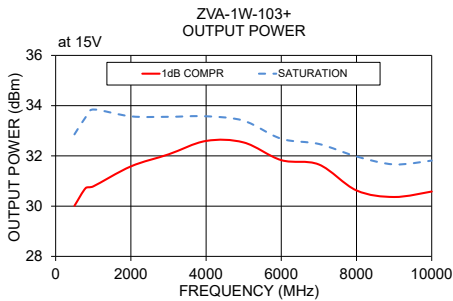
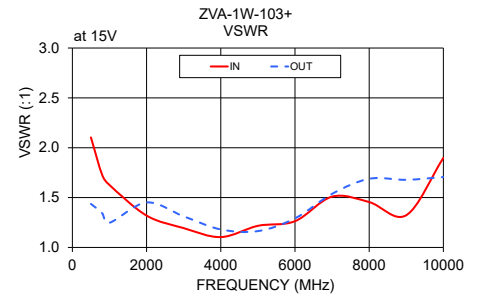
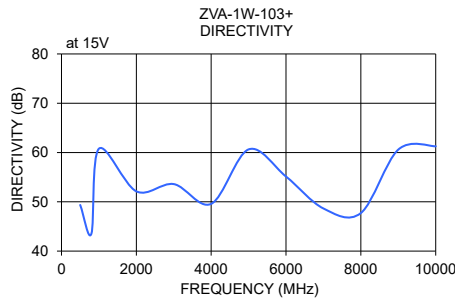
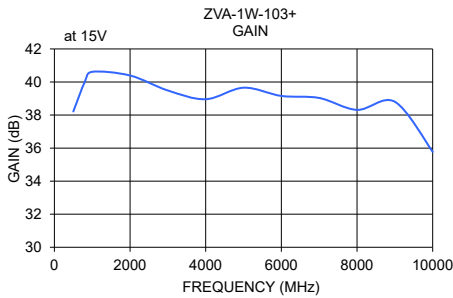

NOTES

- A. Performance and quality attributes and conditions not expressly stated in this specification document are intended to be excluded and do not form a part of this specification document.
- B. Electrical specifications and performance data contained in this specification document are based on Mini-Circuit's applicable established test performance criteria and measurement instructions.
- C. The parts covered by this specification document are subject to Mini-Circuits standard limited warranty and terms and conditions (collectively, "Standard Terms"); Purchasers of this part are entitled to the rights and benefits contained there in. For a full statement of the standard. Terms and the exclusive rights and remedies thereunder, please visit Mini-Circuits' website at www.minicircuits.com/MCLStore/terms.jsp