



COAXIAL WIDEBAND

Digital Step Attenuator **ZX76-50G-30-V+**

50Ω 0 to 31.5 dB, 0.5 dB Step 100 MHz to 50 GHz
6 Bit, Parallel Control Interface, Dual or Single supply voltage

THE BIG DEAL

- Wideband, operates up to 50 GHz
- Immune to latchup
- High IIP3, 50 dBm
- Low Insertion Loss
- Good VSWR, 1.5:1 Typ
- Glitch-less attenuation transitions
- Dual or Single supply voltage: Vdd=+3.3V



Generic photo used for illustration purposes only

| | |
|-------------------|----------------|
| Model No. | ZX76-50G-30-V+ |
| Case Style | MS3009 |
| Connectors | 2.4 mm |

APPLICATIONS

- Test Setup
- 5G
- Satellite Communications
- X band, S band, C band, KU band, and K band Radars
- EW Test Sets

+RoHS Compliant

The +Suffix identifies RoHS Compliance. See our web site for RoHS Compliance methodologies and qualifications

PRODUCT OVERVIEW

The ZX76-50G-30-V+ is a 50Ω Digital Step Attenuator that provides adjustable attenuation from 0 to 31.5 dB in 0.5 dB steps. The control is a 6-bit parallel interface, with a single positive supply voltage. The model is produced using a unique unibody case package for ruggedness and operation in tough environments.

KEY FEATURES

| Feature | Advantages |
|---|--|
| Wideband operation, specified from 100 MHz to 50 GHz | Can be used in multiple applications such as communications, satellite and defense, reducing part count. |
| Parallel control interface with wide control voltage range | Uses a simple parallel control interface with no clock required. |
| Good VSWR, 1.5:1 typ. | Eases interfacing with adjacent components and results in low amplitude ripple. |
| Glitch-less attenuation transitions | The ZX76-50G-30-V+ employs novel architecture to reduce the RF output power spikes during attenuation transition to 0.3 dB Typ thus reducing noise in the system and eliminating the risk of a transient spike damaging sensitive components in the system. |
| Positive and negative power supply. Single positive supply is available | The use of a single positive supply simplifies power supply design. An internal negative voltage generator supplies the desired negative voltage. Single positive supply results in excellent spurious performance. For applications that require the lowest possible spur performance negative voltage can be applied externally to bypass the internal negative voltage generator. |
| Power Supply +2.3 to +5.5 V | Model suitable for both 5V and 3.3V systems applications with no voltage dividers or multipliers needed. |

**RF ELECTRICAL SPECIFICATIONS, 100 MHz - 50 GHz, T_{AMB}=25°C, V_{DD}=+3.3V**

| Parameter | Frequency (GHz) | Min. | Typ. | Max. | Units |
|---|-----------------|------|-------------|------|-------|
| Insertion Loss @ 0dB Attenuation Setting | 0.1 - 15 | — | 3.25 | 5.5 | dB |
| | 15 - 35 | — | 6.00 | 7.00 | |
| | 35 - 50 | — | 8.00 | 9.5 | |
| Accuracy @ 0.5 dB Attenuation Setting | 0.1 - 15 | — | 0.45 ± 0.15 | — | dB |
| | 15 - 35 | — | 0.40 ± 0.15 | — | |
| | 35 - 50 | — | 0.35 ± 0.15 | — | |
| Accuracy @ 1 dB Attenuation Setting | 0.1 - 15 | — | 0.85 ± 0.25 | — | dB |
| | 15 - 35 | — | 0.8 ± 0.3 | — | |
| | 35 - 50 | — | 0.6 ± 0.3 | — | |
| Accuracy @ 2 dB Attenuation Setting | 0.1 - 15 | — | 2.3 ± 0.3 | — | dB |
| | 15 - 35 | — | 2.4 ± 0.4 | — | |
| | 35 - 50 | — | 2.4 ± 0.6 | — | |
| Accuracy @ 4 dB Attenuation Setting | 0.1 - 15 | — | 4.15 ± 0.15 | — | dB |
| | 15 - 35 | — | 4.1 ± 0.2 | — | |
| | 35 - 50 | — | 4.0 ± 0.3 | — | |
| Accuracy @ 8 dB Attenuation Setting | 0.1 - 15 | — | 8.3 ± 0.3 | — | dB |
| | 15 - 35 | — | 8.5 ± 0.5 | — | |
| | 35 - 50 | — | 8.3 ± 0.6 | — | |
| Attenuation level @ 16 dB Attenuation Setting | 0.1 - 15 | — | 16.6 ± 0.6 | — | dB |
| | 15 - 35 | — | 16.9 ± 0.7 | — | |
| | 35 - 50 | — | 17.3 ± 0.9 | — | |
| Attenuation level @ 31.5 dB Attenuation Setting | 0.1 - 15 | — | 33 ± 1.0 | — | dB |
| | 15 - 35 | — | 34.5 ± 1.5 | — | |
| | 35 - 50 | — | 35.5 ± 1.7 | — | |
| Input IP3 | 2 - 16 | — | +50 | — | dBm |
| Input Power @ 1 dB Compression | 0.1 - 50 | +22 | — | — | |
| VSWR | 0.1 - 25 | — | 1.3 | 2.5 | :1 |
| | 25 - 50 | — | 1.5 | 2.5 | |

DC ELECTRICAL SPECIFICATIONS

| Parameter | Min. | Typ. | Max. | Units |
|--|-------|------|------|-------|
| Positive Supply Voltage, V _{DD} | +2.3 | +3.3 | +5.5 | V |
| Positive Supply Current, I _{DD} | — | 170 | 250 | μA |
| Negative Supply Voltage, V _{CC} | -3.3 | -3.0 | -2.7 | V |
| Negative Supply Current, I _{CC} | -40 | -16 | — | μA |
| Digital Input High | +1.17 | — | +3.6 | V |
| Digital Input Low | -0.3 | — | +0.6 | V |
| Digital Input Current | — | 10 | 20 | μA |
| Control Input Low | -0.3 | — | +0.6 | V |
| Control Input High | +1.17 | — | +5.5 | V |
| Control Current | — | — | 400 | μA |

SWITCHING SPECIFICATIONS

| Parameter | Min. | Typ. | Max. | Units |
|--|------|------|------|-------|
| Switching Speed, 50% Control to 0.5dB of Attenuation Value | — | 330 | 400 | nsec |

ABSOLUTE MAXIMUM RATINGS

| Parameter | Ratings |
|------------------------------|------------------------|
| Operating Temperature | 0°C to 50°C |
| Storage Temperature | -20°C to 85°C |
| V _{DD} | -0.3V Min., +6V Max. |
| V _{SS} | -3.6V Min., +0.3V Max. |
| Voltage on any control input | -0.3V Min., +3.6V Max. |
| ESD, HBM | 1000V |
| Maximum Input Power | +28dBm |



Digital Step Attenuator ZX76-50G-30-V+

PIN CONFIGURATION (TOP VIEW)

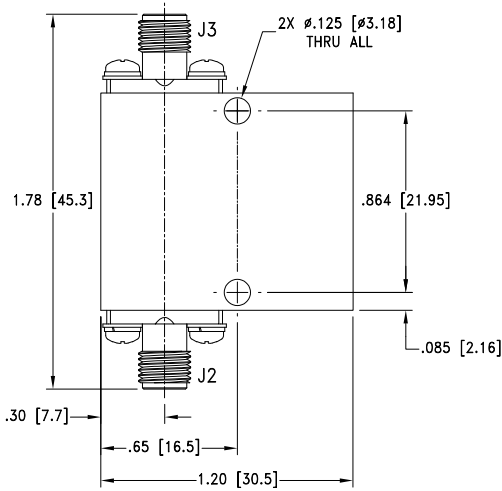

PIN DESCRIPTION

| Function | Pin Number | Description |
|----------|------------|--------------------------------------|
| +3.3V | J1-1 | Positive Supply Voltage |
| LE | J1-2 | Latch Enable Input |
| C0.5 | J1-3 | Control for attenuation bit, 0.5 dB |
| C1 | J1-4 | Control for attenuation bit, 1.0 dB |
| C4 | J1-5 | Control for attenuation bit, 4.0 dB |
| C2 | J1-6 | Control for attenuation bit, 2 dB |
| C8 | J1-7 | Control for attenuation bit, 8 dB |
| C16 | J1-8 | Control for attenuation bit, 16 dB |
| +3.3V | J1-9 | Positive Supply Voltage |
| -3.3V | J1-10 | Negative Supply Voltage ² |
| RF in | J2 | RF in port ¹ |
| RF out | J3 | RF out port ¹ |

Note 1: Both RF ports are DC blocked with an internal series capacitors.
 Note 2: If Pin J1-10 is grounded the internal negative voltage will be generated.

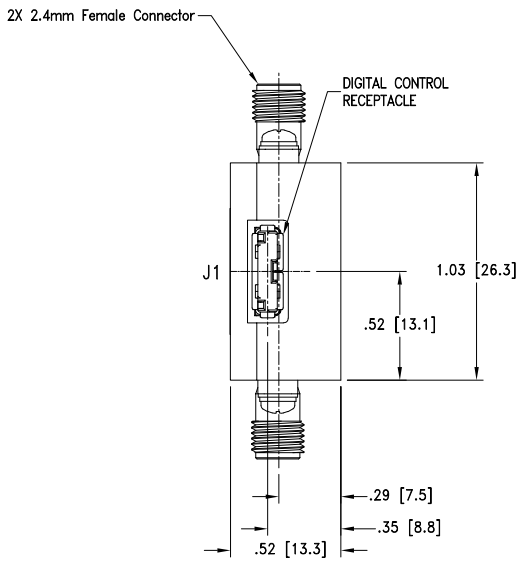



SIMPLIFIED SCHEMATIC

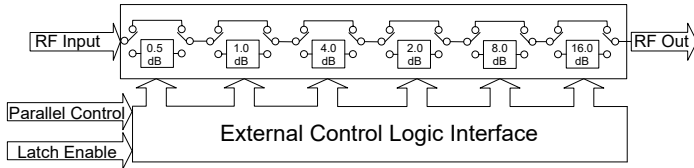

The ZX76-50G-30-V+ parallel interface consists of 6 control bits that select the desired attenuation state, as shown in Table 1: Truth Table.

TABLE 1. TRUTH TABLE

| Attenuation State | C16 | C8 | C4 | C2 | C1 | C0.5 |
|-------------------|-----|----|----|----|----|------|
| Reference | 0 | 0 | 0 | 0 | 0 | 0 |
| 0.5 (dB) | 0 | 0 | 0 | 0 | 0 | 1 |
| 1 (dB) | 0 | 0 | 0 | 0 | 1 | 0 |
| 2 (dB) | 0 | 0 | 0 | 1 | 0 | 0 |
| 4 (dB) | 0 | 0 | 1 | 0 | 0 | 0 |
| 8 (dB) | 0 | 1 | 0 | 0 | 0 | 0 |
| 16 (dB) | 1 | 0 | 0 | 0 | 0 | 0 |
| 31.5 (dB) | 1 | 1 | 1 | 1 | 1 | 1 |

Note: Not all 64 possible combinations of C0.5 - C16 are shown in table

The parallel interface timing requirements are defined by Figure 1 (Parallel Interface Timing Diagram) and Table 2 (Parallel Interface AC Characteristics), and the switching speed.

For latched parallel programming the Latch Enable (LE) should be held LOW while changing attenuation state control values, then pulse LE HIGH to LOW (per Figure 1) to latch new attenuation state into the device.

For direct parallel programming, the Latch Enable (LE) line should be pulled HIGH. Changing the attenuation state control values will immediately change the device's state to a new attenuation value. Direct mode is ideal for manual control of the device (using hardware, switches, or jumpers).

TABLE 2. PARALLEL INTERFACE AC CHARACTERISTICS

| Symbol | Parameter | Min. | Units |
|-------------|---|------|-------|
| t_{LEPW} | LE minimum pulse width | 10 | ns |
| t_{PDSUP} | Data set-up time before clock rising edge of LE | 10 | ns |
| t_{PDHLD} | Data hold time after clock falling edge of LE | 10 | ns |

FIGURE 1: PARALLEL INTERFACE TIMING DIAGRAM

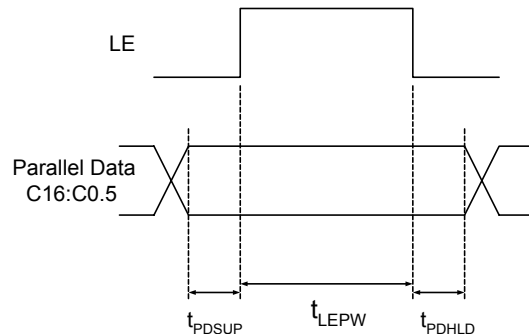

POWER-UP STATE

When the attenuator powers up and LE is logic low, the maximum attenuation is set to 31.5 dB. When LE is logic high, the nominal attenuation selected upon control logics (see Table 1). When LE is logic HIGH upon turn on, the start-up attenuation value will be set based on the control logic in Table 1.



Digital Step Attenuator **ZX76-50G-30-V+**

CBL-5FT-MPD+ CONTROL CABLE

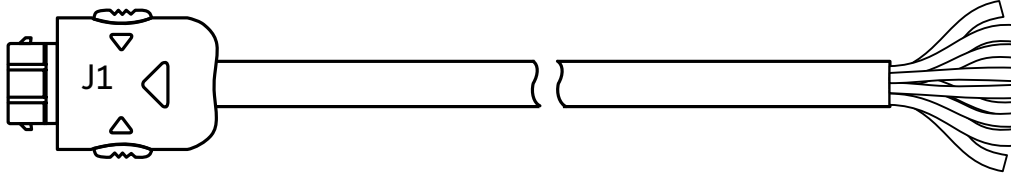

INCLUDED ACCESSORIES

CBL-5FT-MPD+ is a "Pigtail" connector included with every purchase of ZX76-50G-30-V+. CBL-5FT-MPD+ is a shielded cable with stripped wires (#32AWG) on one end and a connector on the other end designed to mate to the ZX76-50G-30-V+. These bare wires enable the customer to assemble their own cable as required to interface with the ZX76-50G-30-V+ (cable length is 4.9ft/ 1.5meters).

CBL-5FT-MPD+ WIRING INFORMATION

| J1 Pin Number | Function | Description | Wire Color |
|---------------|----------|--------------------------------------|--------------|
| 1 | +3.3V | Positive Supply Voltage | Green |
| 2 | LE | Latch Enable Input | Green/Black |
| 3 | C0.5 | Control for attenuation bit, 0.5 dB | Red |
| 4 | C1 | Control for attenuation bit, 1.0 dB | Orange |
| 5 | C4 | Control for attenuation bit, 4.0 dB | Orange/Black |
| 6 | C2 | Control for attenuation bit, 2.0 dB | Black |
| 7 | C8 | Control for attenuation bit, 8.0 dB | Red/Black |
| 8 | C16 | Control for attenuation bit, 16.0 dB | Blue |
| 9 | +3.3V | Positive Supply Voltage | White |
| 10 | -3.3V | Negative Supply Voltage (ex ground) | White/Black |
| Shield | - | Shield Braid/ Drain | - |

Note: Cable shield connected to case ground.



Digital Step Attenuator ZX76-50G-30-V+

TYPICAL PERFORMANCE DATA

| Frequency (MHz) | Insertion loss (dB) | Attenuation relative to insertion loss @Attenuation settings | | | | | | |
|-----------------|---------------------|--|------|------|------|------|-------|--------|
| | | 0.5dB | 1dB | 2dB | 4dB | 8dB | 16dB | 31.5dB |
| 100 | 1.45 | 0.48 | 0.91 | 2.15 | 4.20 | 8.14 | 16.24 | 32.10 |
| 500 | 1.57 | 0.49 | 0.92 | 2.14 | 4.21 | 8.16 | 16.26 | 32.12 |
| 1000 | 1.64 | 0.49 | 0.93 | 2.12 | 4.23 | 8.17 | 16.28 | 32.15 |
| 5000 | 2.16 | 0.47 | 0.89 | 2.16 | 4.19 | 8.12 | 16.27 | 32.21 |
| 10000 | 3.94 | 0.39 | 0.76 | 2.35 | 4.08 | 8.05 | 16.19 | 32.27 |
| 15000 | 4.84 | 0.49 | 0.92 | 2.09 | 4.19 | 8.27 | 16.68 | 32.76 |
| 20000 | 5.12 | 0.36 | 0.75 | 2.04 | 3.97 | 8.04 | 16.37 | 32.31 |
| 25000 | 5.54 | 0.29 | 0.70 | 2.44 | 4.14 | 8.35 | 16.46 | 32.03 |
| 30000 | 6.14 | 0.30 | 0.68 | 2.41 | 4.01 | 8.30 | 16.44 | 32.29 |
| 35000 | 6.00 | 0.30 | 0.72 | 2.43 | 4.10 | 8.62 | 17.08 | 34.58 |
| 40000 | 6.82 | 0.30 | 0.63 | 2.36 | 3.94 | 8.32 | 16.80 | 34.11 |
| 45000 | 7.46 | 0.35 | 0.49 | 2.69 | 3.97 | 8.54 | 17.40 | 34.68 |
| 50000 | 8.06 | 0.36 | 0.59 | 2.35 | 4.01 | 8.52 | 17.59 | 35.32 |
| 53000 | 9.22 | 0.35 | 0.59 | 2.23 | 3.94 | 8.31 | 17.44 | 34.51 |

| Frequency (MHz) | VSWR In (:1) @Attenuation Settings | | | | | | | | VSWR Out (:1) @Attenuation Settings | | | | | | | |
|-----------------|------------------------------------|-------|------|------|------|------|------|--------|-------------------------------------|-------|------|------|------|------|------|--------|
| | 0dB | 0.5dB | 1dB | 2dB | 4dB | 8dB | 16dB | 31.5dB | 0dB | 0.5dB | 1dB | 2dB | 4dB | 8dB | 16dB | 31.5dB |
| 100 | 1.40 | 1.28 | 1.21 | 1.63 | 1.10 | 1.21 | 1.06 | 1.09 | 1.31 | 1.20 | 1.12 | 1.63 | 1.22 | 1.08 | 1.09 | 1.09 |
| 500 | 1.39 | 1.27 | 1.20 | 1.62 | 1.09 | 1.21 | 1.05 | 1.07 | 1.33 | 1.21 | 1.11 | 1.66 | 1.23 | 1.06 | 1.07 | 1.07 |
| 1000 | 1.40 | 1.30 | 1.23 | 1.62 | 1.12 | 1.22 | 1.10 | 1.11 | 1.38 | 1.26 | 1.16 | 1.69 | 1.26 | 1.11 | 1.11 | 1.11 |
| 5000 | 1.19 | 1.11 | 1.08 | 1.39 | 1.04 | 1.13 | 1.08 | 1.13 | 1.22 | 1.12 | 1.05 | 1.50 | 1.13 | 1.09 | 1.11 | 1.11 |
| 10000 | 1.13 | 1.08 | 1.04 | 1.34 | 1.21 | 1.16 | 1.10 | 1.22 | 1.17 | 1.17 | 1.24 | 1.30 | 1.15 | 1.25 | 1.24 | 1.25 |
| 15000 | 1.47 | 1.40 | 1.41 | 1.54 | 1.29 | 1.39 | 1.14 | 1.18 | 1.55 | 1.45 | 1.39 | 1.73 | 1.40 | 1.25 | 1.22 | 1.22 |
| 20000 | 1.11 | 1.07 | 1.04 | 1.15 | 1.12 | 1.12 | 1.21 | 1.13 | 1.31 | 1.35 | 1.42 | 1.02 | 1.18 | 1.33 | 1.31 | 1.32 |
| 25000 | 1.48 | 1.46 | 1.36 | 1.53 | 1.51 | 1.30 | 1.49 | 1.52 | 1.62 | 1.67 | 1.77 | 1.26 | 1.43 | 1.63 | 1.58 | 1.58 |
| 30000 | 1.64 | 1.64 | 1.74 | 1.56 | 1.69 | 1.73 | 1.42 | 1.63 | 1.40 | 1.35 | 1.36 | 1.67 | 1.51 | 1.55 | 1.58 | 1.56 |
| 35000 | 1.53 | 1.58 | 1.59 | 1.33 | 1.44 | 1.39 | 1.36 | 1.35 | 1.26 | 1.22 | 1.15 | 1.56 | 1.30 | 1.26 | 1.29 | 1.28 |
| 40000 | 1.30 | 1.33 | 1.31 | 1.17 | 1.23 | 1.11 | 1.21 | 1.12 | 1.35 | 1.34 | 1.23 | 1.44 | 1.20 | 1.03 | 1.01 | 1.02 |
| 45000 | 1.09 | 1.10 | 1.05 | 1.28 | 1.13 | 1.30 | 1.48 | 1.24 | 1.10 | 1.08 | 1.01 | 1.32 | 1.10 | 1.08 | 1.08 | 1.08 |
| 50000 | 1.13 | 1.11 | 1.17 | 1.06 | 1.15 | 1.01 | 1.13 | 1.08 | 1.31 | 1.35 | 1.31 | 1.21 | 1.32 | 1.12 | 1.12 | 1.09 |
| 53000 | 1.89 | 1.86 | 1.84 | 2.02 | 1.72 | 1.92 | 2.15 | 1.86 | 2.19 | 2.25 | 2.12 | 2.01 | 2.17 | 1.70 | 1.70 | 1.71 |



Digital Step Attenuator ZX76-50G-30-V+

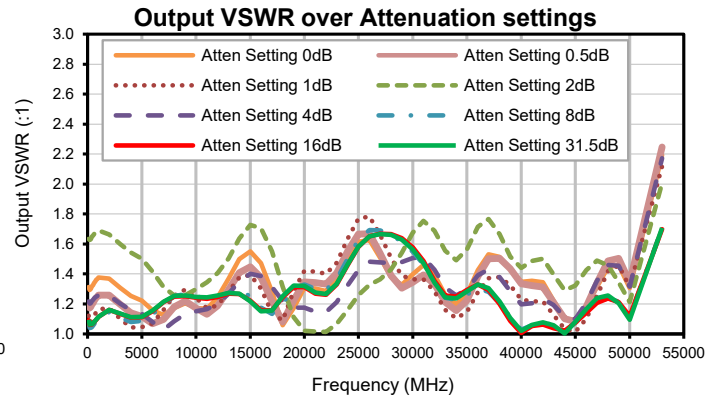
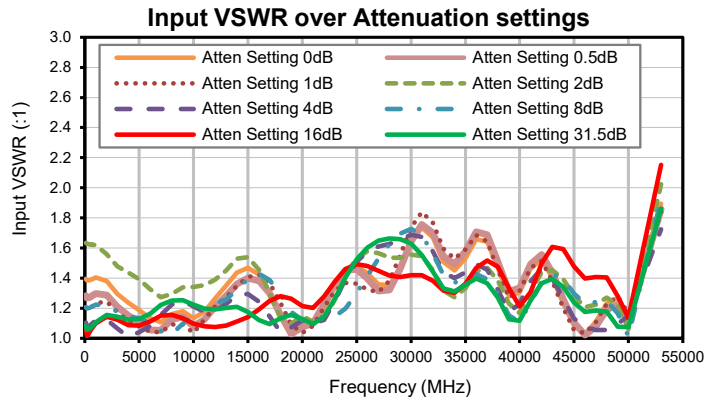
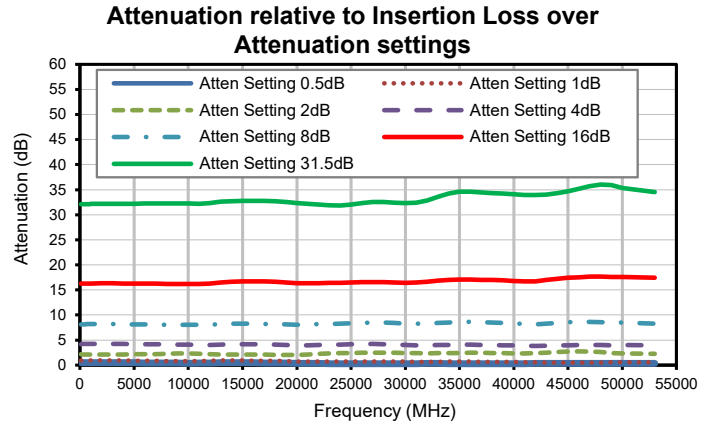
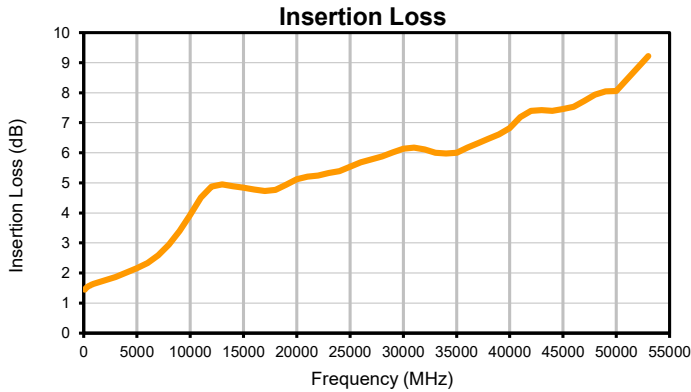



COAXIAL WIDEBAND

Digital Step Attenuator **ZX76-50G-30-V+**

Mini-Circuits

ORDERING INFORMATION

| Model | Description |
|----------------|--|
| ZX76-50G-30-V+ | Digital attenuator - Dual or Single Supply Voltage |

| Included Accessories | Part No. | Description |
|---|--------------|----------------------------|
|  | CBL-5FT-MPD+ | 5 ft. (1.5M) Control Cable |

NOTES

- A. Performance and quality attributes and conditions not expressly stated in this specification document are intended to be excluded and do not form a part of this specification document.
- B. Electrical specifications and performance data contained in this specification document are based on Mini-Circuit's applicable established test performance criteria and measurement instructions.
- C. The parts covered by this specification document are subject to Mini-Circuits standard limited warranty and terms and conditions (collectively, "Standard Terms"); Purchasers of this part are entitled to the rights and benefits contained therein. For a full statement of the standard. Terms and the exclusive rights and remedies thereunder, please visit Mini-Circuits' website at www.minicircuits.com/MCLStore/terms.jsp

