

USER GUIDE

Mechanical Switch Assemblies

RCMX Series

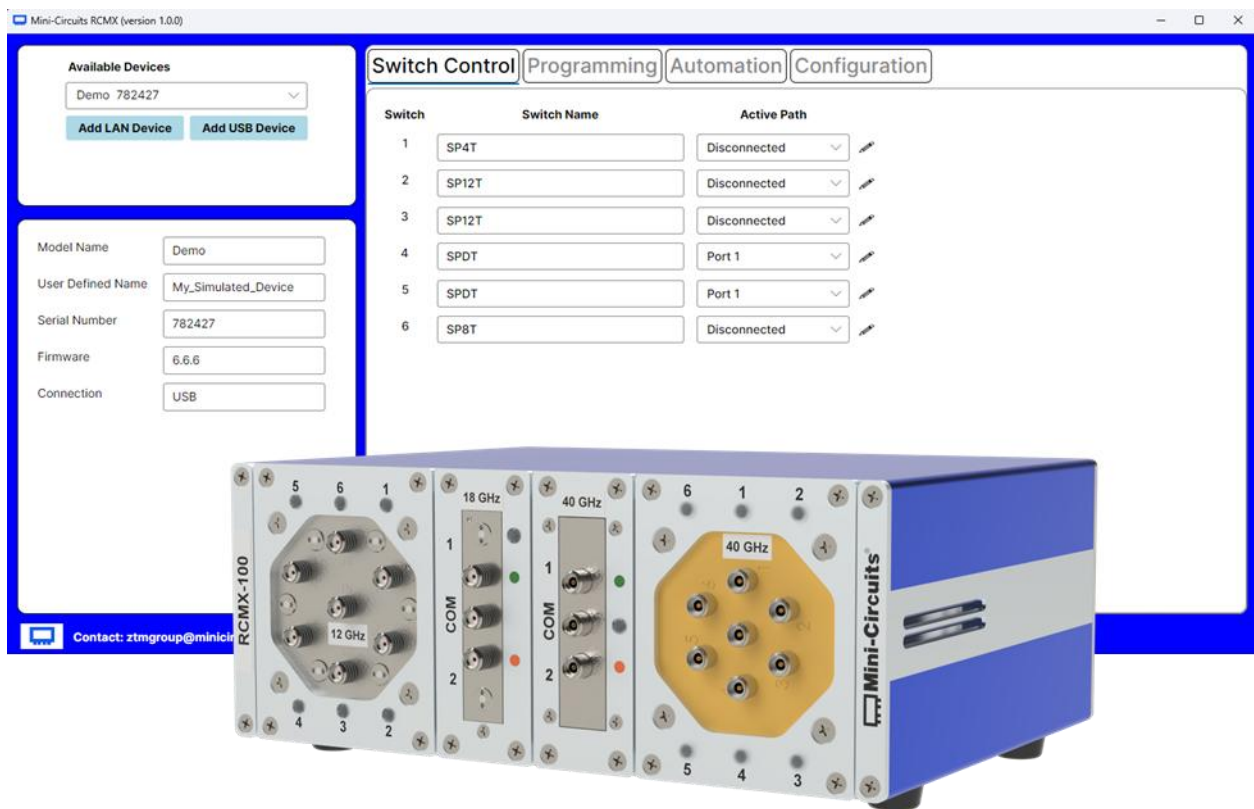

Contents

- 1. Overview..... 3
 - 1.1. Scope 3
 - 1.2. Programming Manual..... 3
 - 1.3. Support Contacts..... 3
 - 1.4. Warranty & RMA Returns..... 3
 - 1.5. End of Life..... 3
 - 1.6. Languages..... 4
- 2. Introduction to Mini-Circuits' RCMX Series..... 4
 - 2.1. Key Features..... 4
 - 2.2. Supported Model List..... 4
 - 2.3. Included Accessories 4
 - 2.4. AC Power Cord Options 5
 - 2.5. Optional Accessories 5
 - 2.6. Intended Applications 5
 - 2.7. Control Interfaces 5
 - 2.8. Conformity 6
 - 2.9. Environmental Specifications 6
 - 2.10. Service & Calibration..... 6
- 3. Hardware Configuration 7
 - 3.1. Safety & Cautions 7
 - 3.1.1. Electrical Hazard..... 7
 - 3.1.2. Heavy Object..... 7
 - 3.1.3. Fan Operation..... 7
 - 3.1.4. Safe Input Levels..... 7
 - 3.1.5. Use of Supplied AC / DC Adapter..... 7
 - 3.2. Front Panel Layout..... 8
 - 3.3. Rear Panel Layout..... 8
 - 3.4. Optional Bracket Assembly 9
 - 3.5. Connection & Power-On..... 9
 - 3.6. Default Switch States..... 10
- 4. Ethernet Communication 11
 - 4.1. Default Ethernet Configuration..... 11
 - 4.2. Default Link-Local / Auto IP Address..... 11
 - 4.3. Recovering / Resetting the Ethernet Configuration 11
 - 4.4. Direct Ethernet Cable Connection to PC..... 12
 - 4.5. Supported Protocols 12
 - 4.5.1. HTTP Communication 12
 - 4.5.2. Telnet Communication 13
 - 4.5.3. SSH Communication..... 14
 - 4.5.4. Disabling HTTP / Telnet Protocols 14
 - 4.5.5. Discovering Connected Devices Using UDP..... 15
 - 4.6. Ethernet Configuration Tool..... 16
- 5. Windows GUI Application..... 17
 - 5.1. Software Download 17
 - 5.2. Launching the Application..... 18
 - 5.3. Connecting USB Devices..... 18
 - 5.4. Connecting Ethernet Devices 19
 - 5.5. Switch Control 20
 - 5.6. Programming..... 21
 - 5.7. Automation..... 22
- 6. Device Configuration 24
 - 6.1. Power-Up Options 24
 - 6.2. Firmware 24
 - 6.3. Logging 25
 - 6.4. Ethernet Configuration..... 26
- 7. Control Options for macOS & Linux..... 27
 - 7.1. Connect & Identify Initial IP Address 27
 - 7.2. Updating the Ethernet Configuration..... 27
 - 7.3. USB Control..... 27
- 8. Contact 28

1. Overview

1.1. Scope

This user guide is intended for RF engineers of any level of experience who intend to operate Mini-Circuits' RCMX series of USB & Ethernet controlled mechanical switch assemblies. It outlines the instructions for software installation, hardware setup and operation. It is recommended that the user familiarize themselves with all aspects of this guide before starting work.

The full software and documentation package including a GUI program, DLL files, user guide and programming examples is available for download from the Mini-Circuits website at:

www.minicircuits.com/WebStore/products/rcmx-modular-test-systems-downloads-and-documentation

For details and specifications on the individual models, please see:

www.minicircuits.com/WebStore/rcm.html

Files made available for download from the Mini-Circuits website are subject to Mini-Circuits' terms of use which are available on the website.

1.2. Programming Manual

This guide focuses on switch control using the supplied Graphical User Interface (GUI). The software support also includes an Application Programming Interface (API) which allows automation of all switch features from most common programming environments, including Python, LabVIEW, C# and many more, via the USB or Ethernet connections.

Full instructions for programming with these models can be found in the programming manual available from our website at:

www.minicircuits.com/softwaredownload/RCMX/Prog_Manual-RCMX.pdf

1.3. Support Contacts

For technical support and assistance, please contact us at the email address below or refer to our website for your local support:

testsolutions@minicircuits.com

www.minicircuits.com/contact/worldwide_tech_support.html

1.4. Warranty & RMA Returns

Mini-Circuits provides a 1-year warranty with all products. Please contact your account manager or refer to our website for full details: www.minicircuits.com/support/ordering.html

If you have any questions or concerns, please contact Mini-Circuits in the first instance through testsolutions@minicircuits.com. Our team will work with you promptly to understand and resolve any issues. As a software-controlled instrument, it is usually possible to resolve issues remotely without requiring the unit to be returned to the factory.

If a return to the factory is necessary, Mini-Circuits will provide an RMA number and full return instructions.

1.5. End of Life

Please contact testsolutions@minicircuits.com to review environmentally friendly end of life disposal options.

1.6. Languages

Please contact testsolutions@minicircuits.com if instructions are required in other languages.

2. Introduction to Mini-Circuits' RCMX Series

Mini-Circuits' RCMX series is a family of compact mechanical switch assemblies with USB and Ethernet control interfaces. Each model houses 1 or more wideband electro-mechanical switch components for a wide range of RF, microwave and millimeter wave switching applications. A software GUI is provided for straightforward "point & click" control, straight out of the box and a comprehensive API is included as standard for users wishing to automate switch operations in most modern programming environments.

2.1. Key Features

- High performance mechanical switches for lab & production
- High isolation and low insertion loss
- Compact & rugged benchtop package
- Ethernet & USB with API for simple automation
- Switch configurations including transfer (DPDT), SPDT, SP4T, SP6T and SP8T
- Frequency options from DC to 67 GHz
- SMA / N-type / 2.92 mm / 2.4 mm / 1.85 mm connector options
- LED switch state indicators on front panel
- Low insertion loss, high isolation and high-power ratings
- 24V DC input with included AC power adapter

2.2. Supported Model List





For full details and specifications of supported models, please refer to the datasheets published on our website: www.minicircuits.com/WebStore/rcm.html

Model Name	Switches	Frequency	Terminations	Configuration	Connectors
RCMX-301	SP8T x 2	DC-32.5 GHz	Absorptive	Normally open	2.92 mm
	SPDT x 2	DC-40 GHz	Absorptive	Fail-safe	
RCMX-2SP8T-E33	SP8T x 2	DC-32.5 GHz	Absorptive	Normally open	2.92 mm
RCMX-2SP8T-E43	SP8T x 2	DC-42.5 GHz	Absorptive	Normally open	2.92 mm
RCMX-2SP4T-E53	SP4T x 2	DC-52.5 GHz	Absorptive	Normally open	2.4 mm
RCMX-2SP6T-E67	SP6T x 2	DC-67 GHz	Absorptive	Latching	1.85 mm

2.3. Included Accessories

Part Number	Description
AC/DC-24-3W1	
	AC/DC 24V DC grounded power adaptor. Operating temperature 0 to +40 °C, max current 2.5A, IEC C4 AC inlet.
CBL-3W1-xx	AC power cord (IEC C5 connector to specified local plug).
USB-CBL-AB-3+	USB cable (2.7ft) type A to type B
CBL-RJ45-MM-5+	Ethernet cable (5 ft)

2.4. AC Power Cord Options

Part Number	Description
 CBL-3W1-US	USA NEMA 5-15 plug (type B) to IEC C5 connector
 CBL-3W1-EU	Europe CEE 7/7 plug (type E/F) to IEC C5 connector
 CBL-3W1-UK	UK BS-1363 plug (type G) to IEC C5 connector
 CBL-3W1-AU	Australia & China AS/NZS 3112 plug (type I) to IEC C5 connector
 CBL-3W1-IL	Israel SI-32 plug (type H) to IEC C5 connector

2.5. Optional Accessories

Part Number	Description
BKT-272-08+	Base mounting bracket (set of 2).

2.6. Intended Applications

Mini-Circuits RCMX series switch assemblies are intended for indoor use in:

- Lab and test equipment setups for both manual and automated measurements
- Control systems
- Automated switching of signal paths

2.7. Control Interfaces

Interface	Details	
Ethernet Control	Supported Protocols	TCP / IP, HTTP, Telnet, SSH, DHCP, UDP
	Max Data Rate	100 Mbps (100 Base-T Full Duplex)
USB Control	Supported Protocols	HID – High Speed
	Min Communication Time ¹	400 μ s typ

¹Based on the USB HID protocol polling interval (125 μ s with 1024 bytes per packet) and no other significant CPU or USB activity

2.8. Conformity

Standard	Summary
CE	Meets the requirements of the following applicable European directives and carries the CE marking accordingly: <ul style="list-style-type: none">• Low Voltage – Directive 2014/35• Electromagnetic Compatibility – Directive 2014/30/EU• Restriction of the Use of certain Hazardous Substances in Electrical and Electronic Equipment (RoHS) – Directive 2015/863
UKCA	Meets the requirements of the following applicable UK directives and carries the UKCA marking accordingly: <ul style="list-style-type: none">• Electrical Equipment (Safety) Regulations 2016• Electromagnetic Compatibility Regulations 2016• The Restriction of the Use of Certain Hazardous Substances in Electrical and Electronic Equipment Regulations 2012
USB 2.0	Meets the specifications of the Universal Serial Bus version 2.0 communication standard as described by USB-IF.
USB HID	Meets the requirements for Universal Serial Bus Human Interface Devices according to the USB-IF Device Class Definition for Human Interface Devices firmware revision 1.11.
TCP / IP	Meets the specifications of the Transmission Control Protocol (TCP) and Internet Protocol (IP) as defined in RFC 791 and RFC 793.
HTTP	Meets the requirements for communicating with the Hypertext Transfer Protocol (HTTP) as defined in RFC 1945.
Telnet	Meets the requirements for communicating with the Telnet protocol, as defined in RFC 854.

2.9. Environmental Specifications

These products are intended for operation in office, laboratory, or production test environments. Do not use in any condition which exceeds the published environmental specifications.

Parameter	Specification
Operating Temperature	0 to 50 °C
Storage Temperature	-20 to 70 °C
Relative Humidity	5% to 85% (non-condensing)
Altitude	Up to 2000 m (6560 ft)
Pollution Degree	2 - Normally only non-conductive pollution occurs (per IEC 61010)

2.10. Service & Calibration

These products do not require any periodic service or calibration. The only user service possible is external cleaning of the case and connectors as needed. Do not use any detergents or spray cleaning solutions to clean the switch box; a soft, damp cloth can be used.

3. Hardware Configuration

3.1. Safety & Cautions

3.1.1. Electrical Hazard



The AC adapter contains live 110 / 220V contacts and should not be disassembled. Users must exercise caution to avoid touching any parts where live voltage may be present to prevent injury or death due to electrical shock. Discontinue use and contact Mini-Circuits in the event of visible damage to any parts.

3.1.2. Heavy Object



Use caution when handling to prevent damage and ensure user safety. Follow safe lifting protocols and use any necessary lifting aids to prevent muscle strain or back injury. The unit must be securely located to avoid potentially damaging the equipment.

3.1.3. Fan Operation



Some units may contain cooling fans with rotating blades that can cause injury if obstructed. Remove any loose articles before working inside the unit case to avoid getting caught in moving parts. Ensure adequate space around the fan vents to allow proper cooling.

3.1.4. Safe Input Levels

Do not exceed the specified RF input power levels to prevent damage to the product.

3.1.5. Use of Supplied AC / DC Adapter

Use of the supplied AC / DC power adapter is recommended to ensure safe operation. Do not exceed the specified DC voltage input level.

3.2. Front Panel Layout

An example front panel layout is shown below. The precise combination of switches, connectors, LED state indicators and labelling varies by model so refer to the model datasheet for full information.

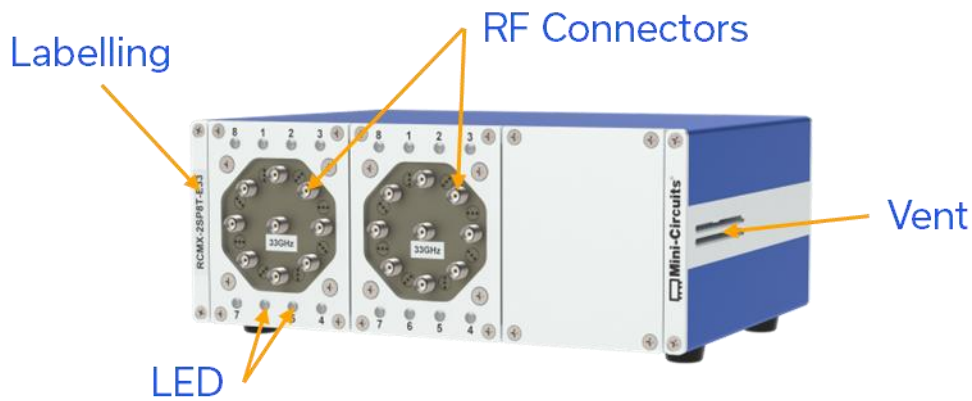

Item	Description
Labelling	Identifying marks for the specific switch box, including model name
RF Connectors	The RF connections for each switch component within the switch assembly. Refer to the datasheet for connector type and quantity.
LEDs	LED state indicators for each switch or port to provide a visual representation of the current switch state(s).
Vents	Ventilation channels to allow air-flow and cooling within the switch assembly. Do not obstruct.

3.3. Rear Panel Layout

An example rear panel layout is shown below. The precise arrangement varies by model so refer to the model datasheet for full information.

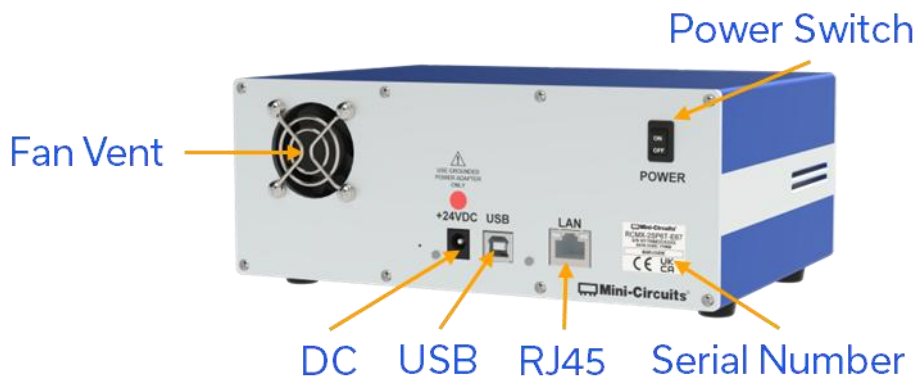

Item	Description
Fan Vent	Ventilation to allow airflow and cooling within the switch box. Do not obstruct.
Serial Number	Serial number which uniquely identifies the unit for traceability
DC	24V DC power supply input
USB	USB type-B control input
RJ45	LAN / Ethernet control input
Labels	Labels for regulatory compliance (varies by model)
Power Switch	Master on / off power switch for the unit

3.4. Optional Bracket Assembly

The optional BKT-272-08+ base-mounting bracket kit can be purchased to provide a simple mechanism for mounting the switch assembly on top of a flat surface, such as a rack tray / shelf.

The kit consists of a pair of metal plates, each with a pair of pre-drilled holes for attaching to the switch assembly and another pair for attaching to the final structure.

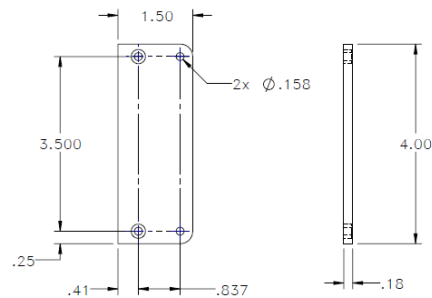

To attach the brackets to the switch assembly:

1. Use a Phillips head screwdriver to unscrew and remove the 4 rubber feet from the bottom of the switch assembly
2. Position the brackets on the bottom of the switch assembly so the pair of counter-bore holes in the bracket line up with the exposed holes where the feet were removed
3. Reuse the 4 screws from the rubber feet to secure the brackets to the switch assembly

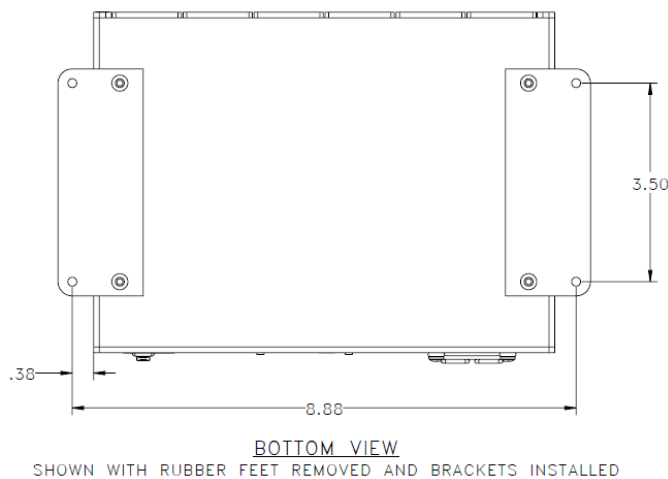

3.5. Connection & Power-On

1. Connect the USB or Ethernet cable between the RCMX switch assembly and the host PC or network
2. Connect the supplied AC / DC power adapter between the RCMX switch assembly and a suitable AC mains power source
3. Power on the switch box with using the rear panel power switch

Note: Only 1 control method is needed but both can be connected for simultaneous use of USB and Ethernet control

3.6. Default Switch States

Mini-Circuits' RCMX series switch assemblies use a range of high-reliability mechanical switches that have well defined actions when the DC power supply is removed or interrupted. The states are summarized below:

Switch Type	Default State	Configuration	Action During DC Power Interruption
SPDT	Com to port 1	Fail-Safe	Reverts to default state
SP4T	All ports disconnected: <ul style="list-style-type: none">• Com open / reflective• Ports 1-4 internally terminated	Normally Open	Reverts to default state
SP6T	All ports disconnected: <ul style="list-style-type: none">• Com open / reflective• Ports 1-6 internally terminated	Normally Open Latching	Reverts to default state Maintains current state (no interruption)
SP8T	All ports disconnected: <ul style="list-style-type: none">• Com open / reflective• Ports 1-8 internally terminated	Normally Open	Reverts to default state

4. Ethernet Communication

Mini-Circuits' RCMX series switch assemblies support Ethernet communication using SSH, HTTP or Telnet protocols. UDP is supported as a method to broadcast a query to the network and identify any connected devices.

These protocols are widely supported and straightforward to implement in most programming environments. Any Internet browser can be used as a console / tester for HTTP control by typing the full URL directly into the address bar. Telnet is supported by a number of console applications, including PuTTY.

The Mini-Circuits GUI can be used for full control of the switch assembly via HTTP, Telnet or SSH.

4.1. Default Ethernet Configuration

Mini-Circuits' products ship with DHCP enabled by default so in most cases the device should be assigned a dynamic IP address when connected to the network. Once a valid IP address has been assigned and identified it can be re-configured in multiple ways:

1. Using the Windows GUI when connected by USB or Ethernet
2. Using the API when connected by USB or Ethernet (refer to the programming manual for details)
3. Using Mini-Circuits' HTML configuration tool when connected by Ethernet

4.2. Default Link-Local / Auto IP Address

A default "link-local" auto IP address will be assumed when DHCP is enabled but the device does not receive a valid response from a DHCP server. This could be the case on networks with no DHCP server when the device is connected directly via an Ethernet cable to a PC instead of via a network.

The default static / link-local IP address for all Mini-Circuits devices with the relevant firmware is 169.254.10.10.

The default auto-IP features provide a method to implement a static IP configuration without first relying on DHCP or resorting to the USB connection. The process would be:

1. Connect the device directly to a PC using the Ethernet cable
2. No DHCP response will be received from the PC so the device will assume the default auto-IP
3. Connect to the device on 169.254.10.10
4. Disable DHCP, set the required static IP configuration and reset the device
5. Reconnect using the updated IP configuration

4.3. Recovering / Resetting the Ethernet Configuration

If an invalid IP configuration is applied and the device can no longer communicate over Ethernet, the configuration can always be read and reset using the USB connection, either using the GUI or the programming API.

Refer to [Ethernet Configuration](#) for instructions using the GUI or to the programming manual for details of the API.

4.4. Direct Ethernet Cable Connection to PC

It may be necessary to set a compatible TCP / IP configuration on a PC to permit a direct connection by Ethernet cable between the device and PC rather than via a network. The values can be chosen arbitrarily as long as a valid and compatible range is applied to both PC and Mini-Circuits device. The key points are:

1. Set different IP addresses on the same subnet for the PC and device
2. Set another different IP address on the same subnet as the network gateway IP, using the same value on both PC and Mini-Circuits device
3. Set the same subnet mask on PC and device (ensuring the mask allows the above IP range)

An example of a working configuration is shown below, with the PC settings on the left and the static IP settings for the Mini-Circuits device on the right.

The image shows two side-by-side network configuration windows. The left window is for a PC, and the right window is for a Mini-Circuits device.

PC Configuration (Left):

- Use the following IP address:
 - IP address: 192 . 168 . 100 . 1
 - Subnet mask: 255 . 255 . 255 . 0
 - Default gateway: 192 . 168 . 100 . 0
- Obtain DNS server address automatically
- Use the following DNS server addresses:
 - Preferred DNS server: 8 . 8 . 8 . 8
 - Alternate DNS server: . . .

Static Configuration (Right):

- IP Address:** 192 . 168 . 100 . 2
- Subnet Mask:** 255 . 255 . 255 . 0
- Network Gateway:** 192 . 168 . 100 . 0

4.5. Supported Protocols

4.5.1. HTTP Communication

HTTP (HyperText Transfer Protocol) is a widely supported method for communication over a network. Mini-Circuits' devices support HTTP communication through the GUI or API (using Get & Post commands). HTTP also permits using a standard web browser for communication with the device.

A password can be enabled and customized to control access using HTTP. The HTTP port can also be adjusted from the default port 80. Refer to [Ethernet Configuration](#) for instructions using the GUI or to the programming manual for details of the API.

Note: Since HTTP is an unencrypted protocol the password will be sent in plain-text over the network.

4.5.2. Telnet Communication

Telnet is a widely supported method for client / server communication over a network. Mini-Circuits supports Telnet communication through the GUI or API.

A password can be enabled and customized to control access using Telnet. The Telnet port can also be adjusted from the default port 23. Refer to [Ethernet Configuration](#) for instructions using the GUI or to the programming manual for details of the API.

Various third-party clients such as PuTTY can also be used for control. On successful connection, the "line feed" character will be returned. If the system has a password enabled, this must be sent as the first command after connection.

Each Telnet command must be terminated with the carriage return and line-feed characters (\r\n). Responses will be similarly terminated.

Note: Since Telnet is an unencrypted protocol the password will be sent in plain-text over the network.

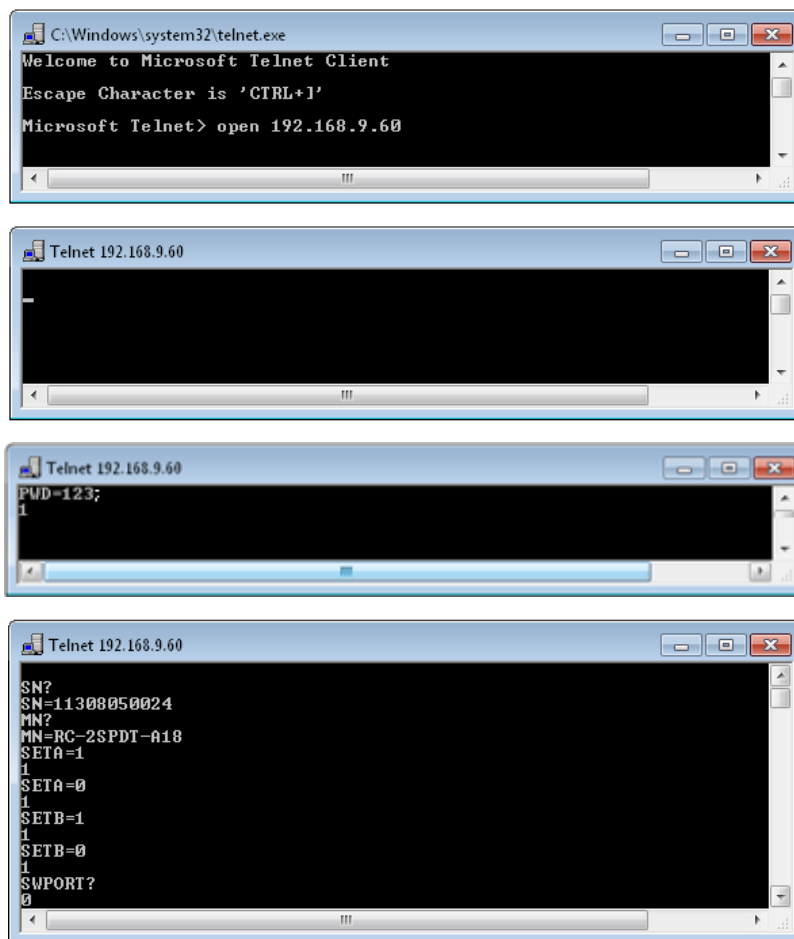

4.5.3. SSH Communication

SSH (Secure Shell) is a secure network communication protocol, with all traffic sent in encrypted form.

A username and password is required for communication with Mini-Circuits' devices using SSH with communication on port 22 by default. The default username (`ssh_user`), password and port can be configured as needed, using the GUI or API. Refer to [Ethernet Configuration](#) for instructions using the GUI or to the programming manual for details of the API.

SSH connections can be initiated using the Mini-Circuits GUI or API, or using a third-part client such as PuTTY.

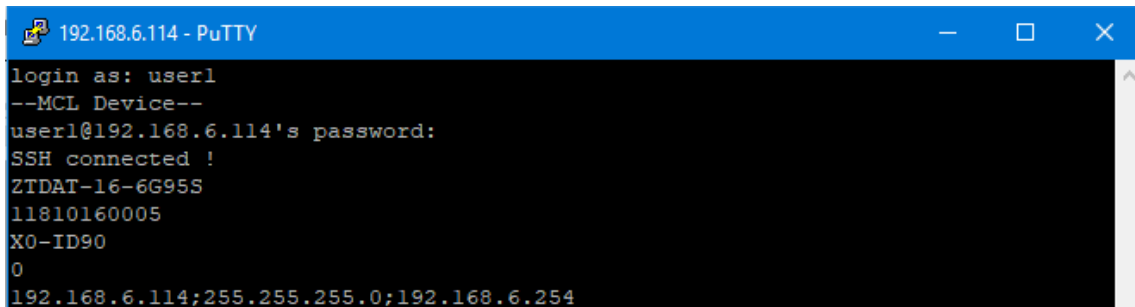

```
192.168.6.114 - PuTTY
login as: user1
--MCL Device--
user1@192.168.6.114's password:
SSH connected !
ZTDAT-16-6G95S
11810160005
X0-ID90
0
192.168.6.114;255.255.255.0;192.168.6.254
```

4.5.4. Disabling HTTP / Telnet Protocols

HTTP and Telnet communication can both be enabled or disabled individually as a means for complying with network security policies which prohibit one or other of these protocols. Set the relevant port to 0 or 65535 to disable the protocol, using either the GUI or programming API.

Refer to [Ethernet Configuration](#) for instructions using the GUI or to the programming manual for details of the API.

4.5.5. Discovering Connected Devices Using UDP

Limited support of UDP is provided for the purpose of discovering Mini-Circuits devices of the same family which are connected to the network. Full control of those units is then accomplished using SSH, HTTP or Telnet, as detailed previously.

Notes:

- UDP is a simple transmission protocol that provides no method for error correction or guarantee of receipt.
- There are routing limitations with UDP broadcast queries which mean it is not usually possible to locate connected devices beyond the local subnet.

Mini-Circuits' Ethernet enabled devices are configured to listen on UDP port 4950 and answer on UDP port 4951. Communication on these ports must be allowed through the computer's firewall in order to use UDP for device discovery. If the switch's IP address is already known, it is not necessary to use UDP.

Mini-Circuits' GUI includes a search function on the initial connection screen which uses UDP. Programmatically, the command `MODULAR-ZT?` can be sent as a broadcast query to the broadcast address of the local network using UDP protocol on port 4950. The broadcast address is worked out from a bitwise OR operation of the host PC's IP address and the bit-complement of its subnet mask.

All related Mini-Circuits devices that receive the request will respond with the following information (each field separated by CrLf) on port 4951:

- Model Name
- Serial Number
- IP Address/Port
- Subnet Mask
- Network Gateway
- Mac Address

Example

Sent Data: `MODULAR-ZT?`

Received Data: `Model Name: RCMX-301
Serial Number: 12602120001
IP Address=192.168.9.101 Port: 80
Subnet Mask=255.255.0.0
Network Gateway=192.168.9.0
Mac Address=D0-73-7F-82-D8-01

Model Name: RCMX-2SP8T-E33
Serial Number: 12602120002
IP Address=192.168.9.102 Port: 80
Subnet Mask=255.255.0.0
Network Gateway=192.168.9.0
Mac Address=D0-73-7F-82-D8-02`

4.6. Ethernet Configuration Tool

Mini-Circuits provides a simple Ethernet configuration tool which can be downloaded as an HTML file from:

https://www.minicircuits.com/softwaredownload/MCL_PTE_Ethernet_Config.zip

The tool provides a method to connect to the device on a known IP address and then set a new IP configuration.

Note:

- Javascript must be enabled in your web browser

To use the tool, download and unzip the package from the link above and open the HTML file in a web browser.

The screenshot shows a web browser window displaying the Mini-Circuits Ethernet Configuration Tool. The browser's address bar shows the file path: file:///F:/LAB4WIN/00/MCL_PTE_Ethernet_Config(X1).HTML. The page title is "Mini-Circuits Test Solutions - Ethernet Configuration Tool (Ver. X1)".

Step 1: Enter the current IP address and password for your device

1. Devices ship with DHCP enabled and no password set
2. If DHCP is not present the device will revert to default IP 169.254.10.10 and subnet mask 255.255.0.0

IP Address: Password:

Step 2: Enter the new IP configuration to set for your device

1. Please ensure a valid configuration is entered which will not clash with other devices on your network
2. To recover an invalid / incompatible IP configuration, connect by USB and use the provided GUI / API

Model Name:

Serial number:

DHCP Enabled

Static IP:

Subnet Mask:

Network Gateway:

HTTP Port:

Telnet Port:

Use Password

Password:

1. Enter the known IP address of the device in the field in Step 1. If the HTTP port is anything other than 80 this must also be entered in the IP address field in the form of ip_address:port
2. Enter the password if one has been enabled for Ethernet control
3. Click Read Current Configuration
4. If the connection is successful, the model name and serial number should be displayed in the Step 2 fields, along with the current IP configuration
5. Overwrite the white Ethernet configuration fields as needed
6. Uncheck the DHCP Enabled field if a static IP configuration is being set
7. Click Set New Configuration to update the device
8. The tool will lose its connection at the old IP address but the device should now be available with the new configuration if valid on the network

5. Windows GUI Application

The RCMX Controller GUI application software is designed to control Mini-Circuits RCMX switch boxes. The RCMX GUI provides functionality to select switch ports for each installed switch, send SCPI programming commands to the instrument, run automated switching sequences, and configure the device ethernet settings.

5.1. Software Download

To install the RCMX GUI software, first download the installer .zip file from the Mini-Circuits website:

<https://www.minicircuits.com/softwaredownload/RCMX/RCMX.Setup.zip>

Installation Steps

1. Unzip the downloaded .zip folder
2. Double-click on the Setup.exe file
3. Follow the prompts to specify the file location and install the software
4. A shortcut will appear on the desktop after installation and in the Mini-Circuits folder available from the Windows Start menu

5.2. Launching the Application

Double-click the RCMX shortcut on the desktop or Windows Start menu to launch the application. The GUI provides 4 tabs for control over the RCMX switch assembly's features and configuration, with the left-hand panel to deal with device connections.

The application will scan for any USB-connected RCMX devices when the program launches. Any devices found will be listed in the Available Devices drop-down. A virtual device (listed as Demo) will always be available in the available devices list for demonstration purposes.

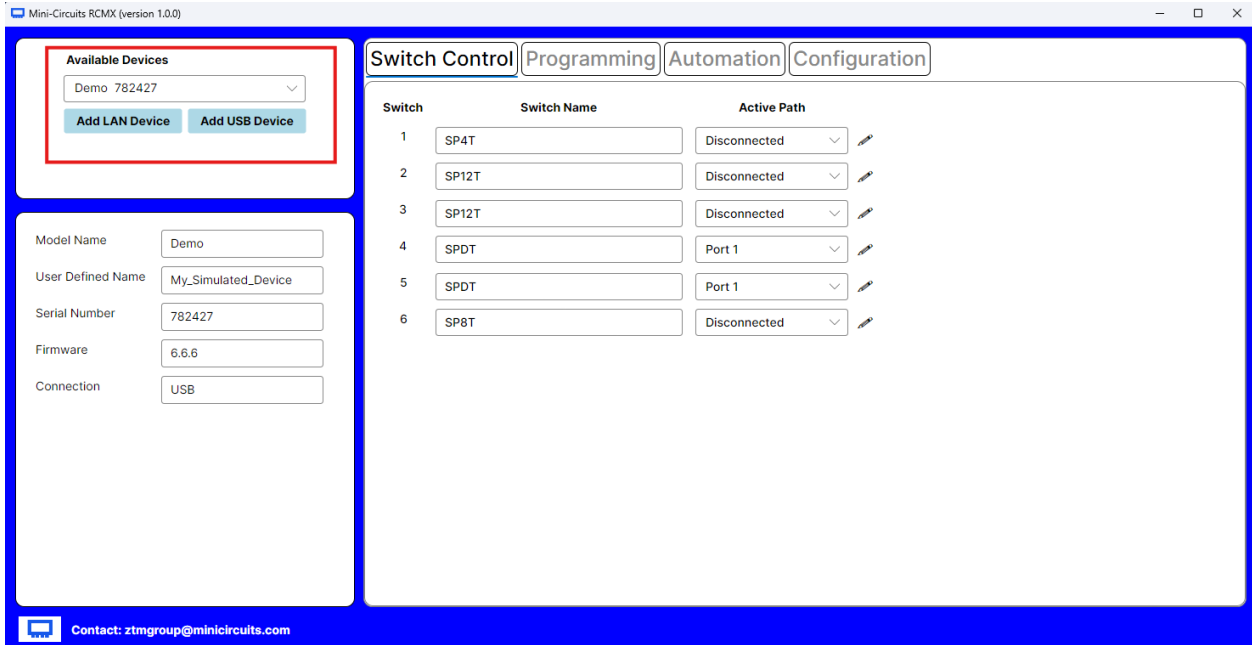

Select any device from the drop-down and the rest of the application will update to display the control parameters and configuration for that device. The device summary window below the drop-down displays important information about the currently selected device including serial number, firmware version, model name and user defined name. The 'User Defined Name' field can be edited to set a custom name for the device.

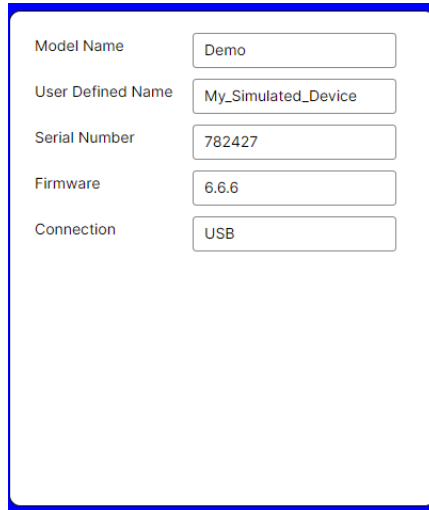

5.3. Connecting USB Devices

Click the "Add USB Device" button to re-scan for new USB devices connected after the application launched. Any new devices found will be added to the Available Devices drop-down. If the connected device is not found, check the hardware power and USB cable connection.

5.4. Connecting Ethernet Devices

Click the "Add LAN Device" button to open the Add Instrument pop-up for connecting additional Ethernet devices.

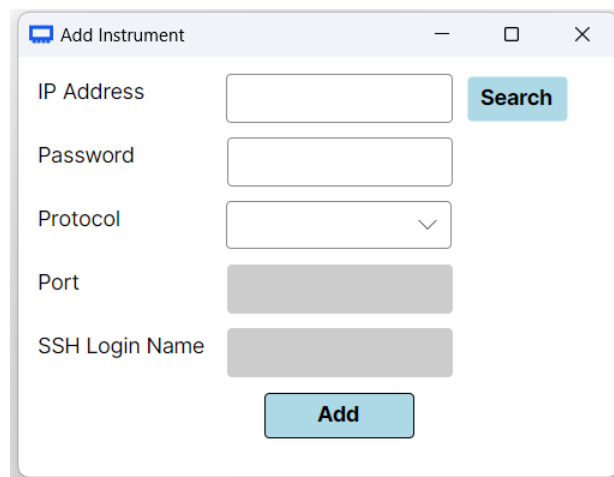

Click the "Search" button to automatically find compatible RCMX devices on your network. The search uses a UDP broadcast query to the local network which prompts all supported Mini-Circuits devices to respond with their identification (model name, serial number and IP address). Select the relevant model from the list of IP addresses.

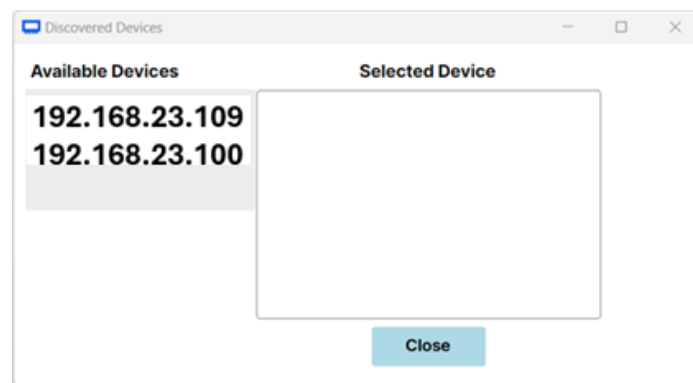

Note:

- The UDP broadcast query requires ports 4950 and 4951 to be open on the computer / network firewall.
- The query uses a best-effort approach but may not be able to identify devices on more complex networks or different subnets. In such cases the device IP can be entered manually to connect.

If the device is not found by the search function, the IP address can be entered manually if known.

Specify the additional connection parameters, including protocol and password (if set) and then click Add Device. The new device will be available to connect in the Available Devices drop-down.

5.5. Switch Control

On the Switch Control tab, use the Active Path drop down to select the desired path for the switch.

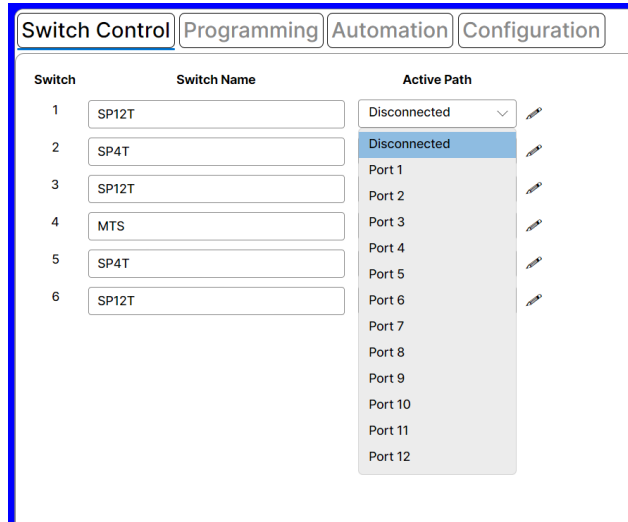

The default switch name corresponds to the switch type but can be edited for a custom name at any time as shown below.

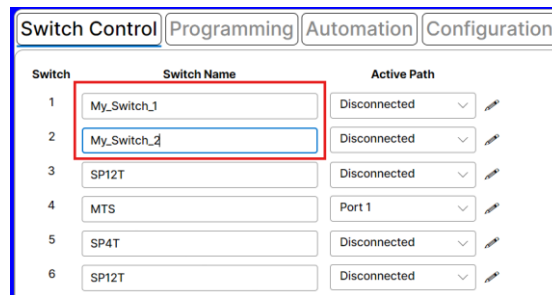

Click on the pencil icon to customize switch path names as shown below.

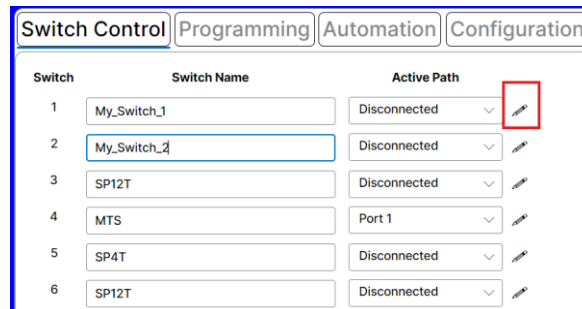

Once you are finished editing path labels, click "Save" to exit the menu, or "Cancel" to revert the labels to their default values.

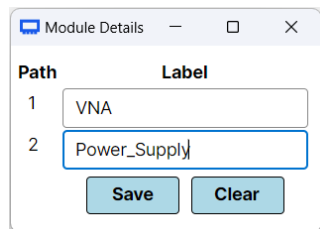

5.6. Programming

To programmatically send commands to the device, select the "Programming" tab as shown below. Custom commands can be sent to the device by typing into the "Command" field and pressing the "Send" button. A list of pre-loaded commands can be selected from the Switch Commands, Switch State Queries, and System Queries drop downs. To clear the command history, select the small eraser icon at the top-right corner of the command history window.

Mini-Circuits RCMX (version 1.0.0)

Available Devices
Demo 715458
Add LAN Device Add USB Device

Model Name Demo
User Defined Name My_Simulated_Device
Serial Number 715458
Firmware 2.9.81
Connection Ethernet
IP Address 192.168.20.86
TCP Port 23
Network Protocol TELNET

Switch Control Programming Automation Configuration

Switch Commands Switch State Queries System Queries

Command
Enter SCPI Command Send

History

Time	Command	Response
------	---------	----------

Contact: ztmgroup@minicircuits.com

5.7. Automation

To run an automated sequence of switching commands, select the Automation tab as shown below.

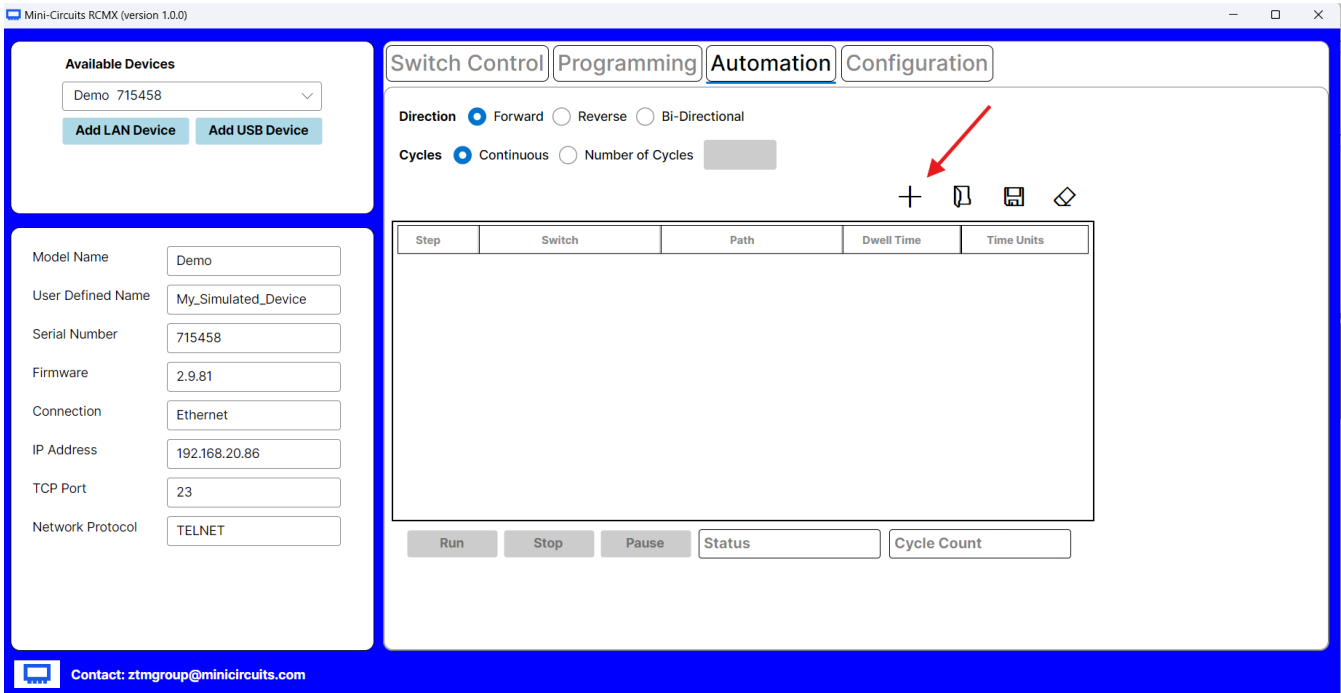

To configure an automation:

1. Click the "+" button for each new automation step to add

Step	Switch	Path	Dwell Time	Time Units
1	4 - MTS	Port 1	100	ms

2. For each step, the following fields must be set:
 - a. Switch number within the RCMX box
 - b. Switch path to set
 - c. Dwell time to pause as each step (the smallest dwell time value is 100 ms)
 - d. Dwell time units
3. The 'X' icon can be used to delete any previously configured step from the automation steps list

Direction Forward Reverse Bi-Directional

Cycles Continuous Number of Cycles

4. Set the direction for the automation to run through the configured sequence:
 - a. Forward – Run through the steps in order entered (from top to bottom)
 - b. Reverse – Run through the steps in reverse order (from bottom to top)
 - c. Bi-directional – Run through the steps in the forward and then reverse directions
5. Enter the desired number of cycles to repeat or select continuous to run indefinitely until manually stopped.

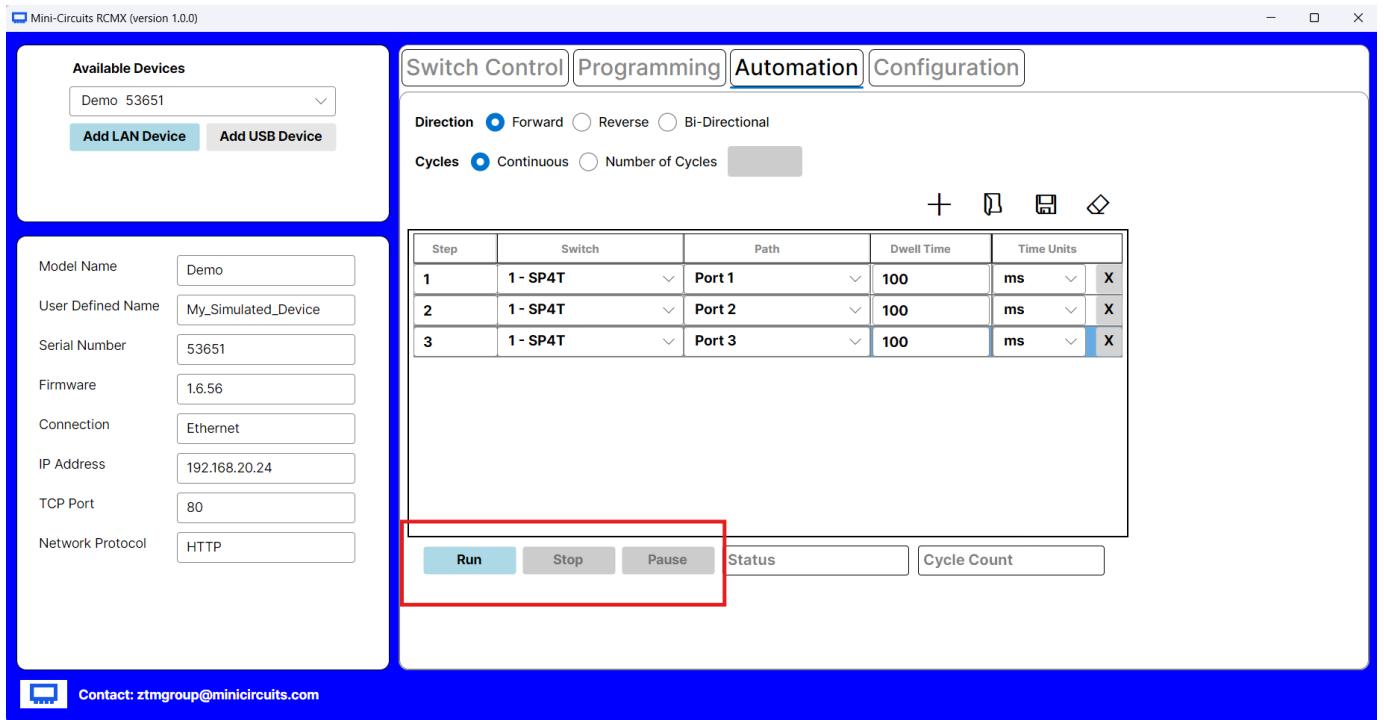

6. Select the 'Run' button to execute the sequence.
7. Select the 'Pause' button to pause the sequence execution at any time.
8. Select the 'Stop' button to terminate the sequence.

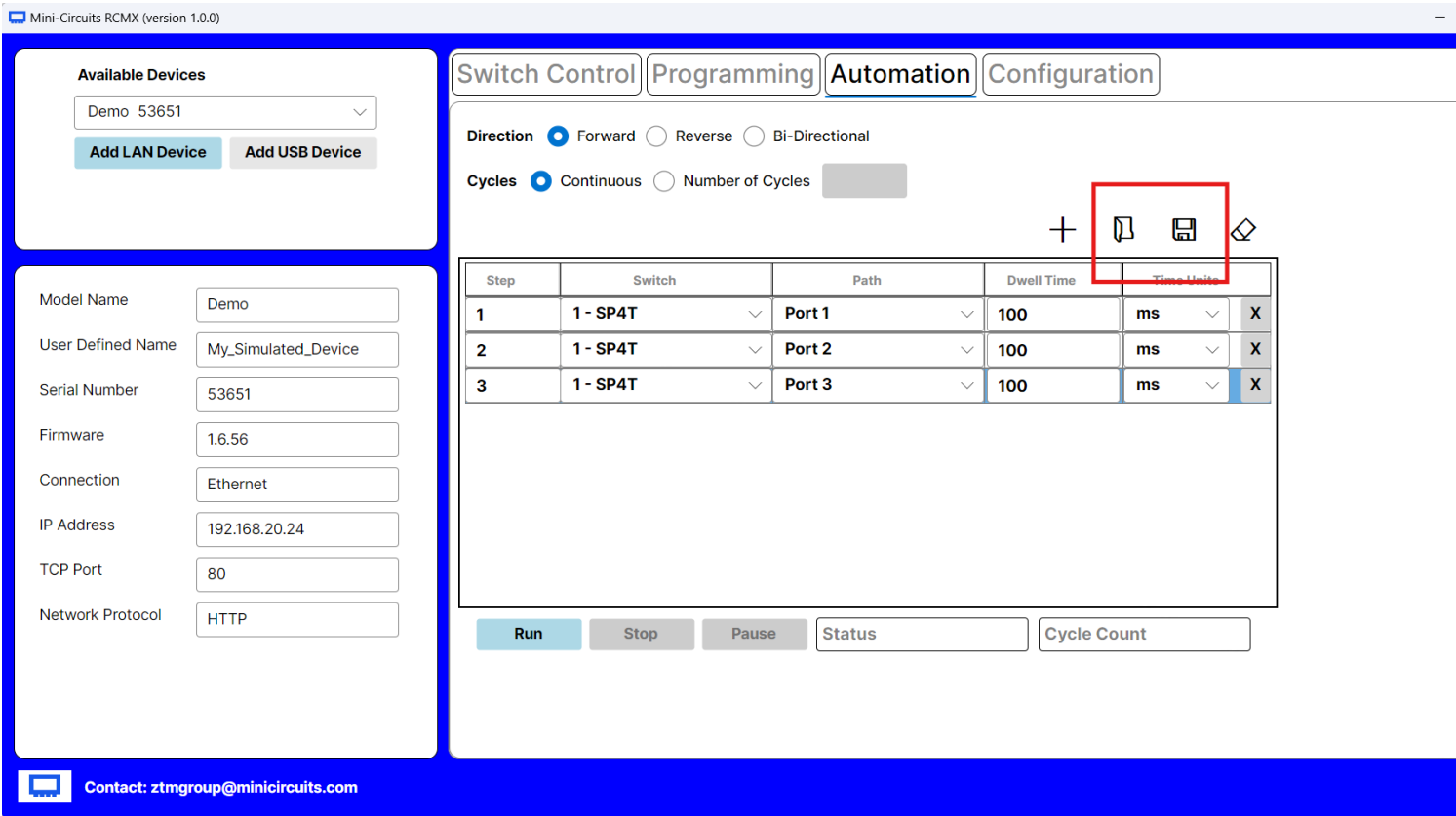

9. Select the disk icon to save the step sequence.
10. Select folder icon to load a saved sequence file.

6. Device Configuration

Select the 'Configuration' tab to view and edit the device settings.

6.1. Power-Up Options

Select the 'default' states radio button so the device powers up with all switches in their default states. Select the 'Last states' radio button so the device powers up with all switches in the same state as when the device was last powered down. Select the 'Save Option' button after making a change.

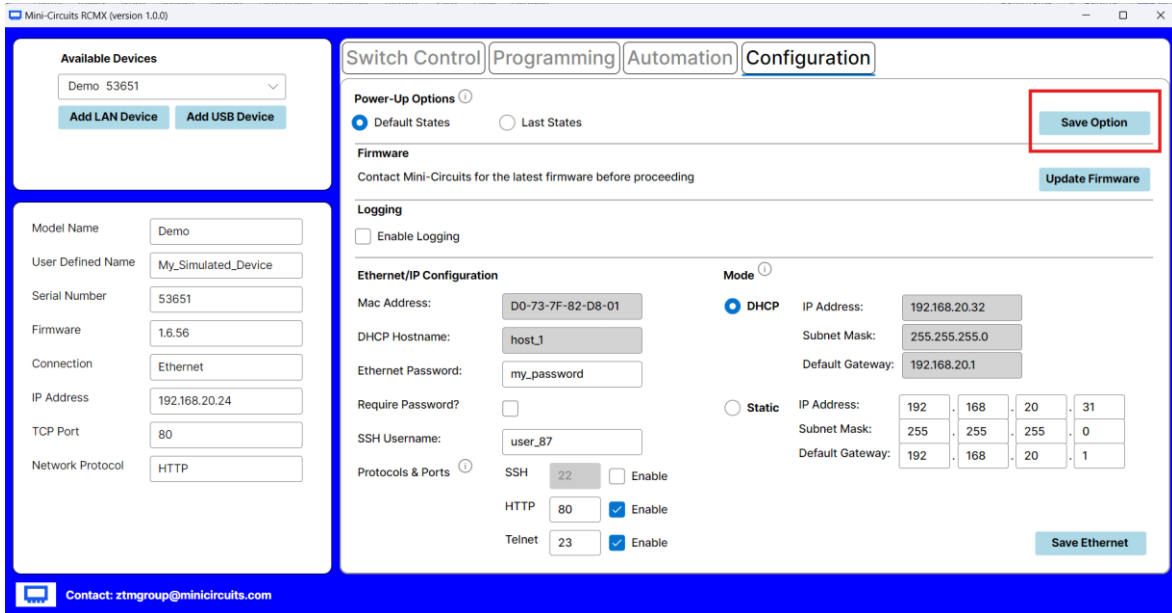

6.2. Firmware

To update the device firmware, make sure you have the latest firmware file saved to your local computer and select the 'Update Firmware' button. Follow the prompts to load firmware to the device. The application will re-load the device into the available devices list once the update has been completed.

Note: updating firmware can only be performed when the device is connected via USB.

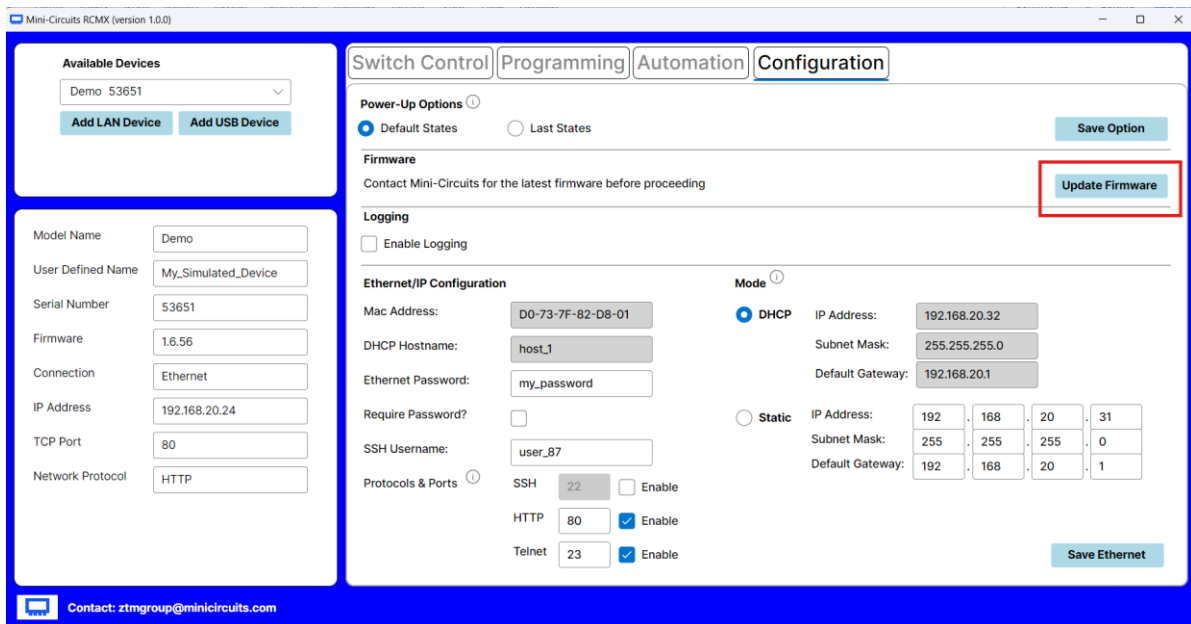

6.3. Logging

Select the 'Enable Logging' checkbox to keep a log of communication between the GUI application and RCMX device. The application will prompt for a file location to store the log file.

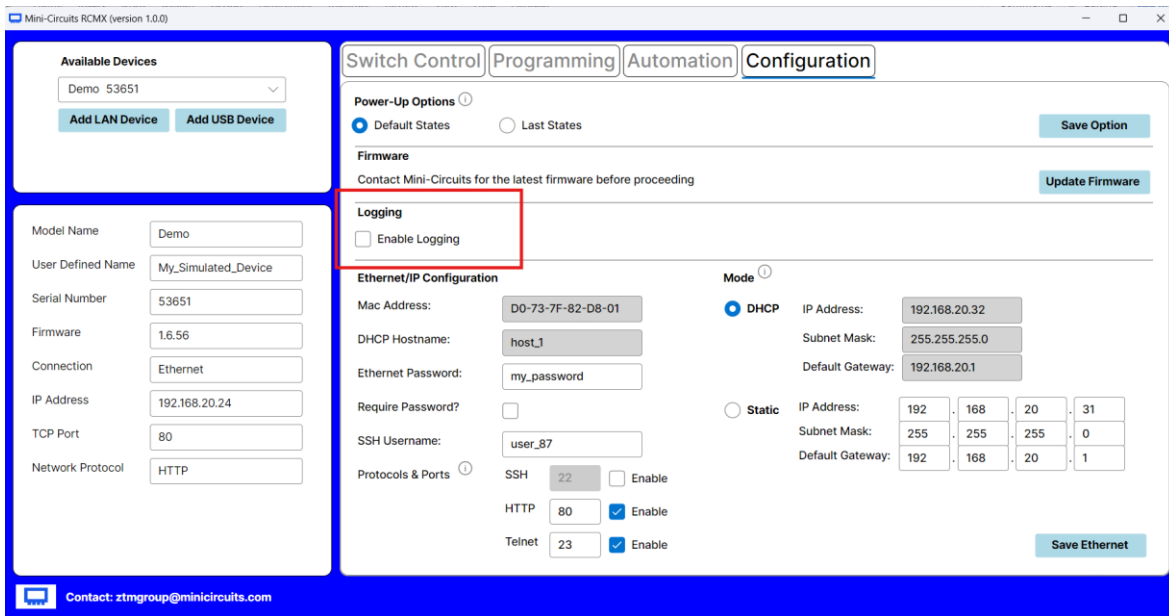

The log file is saved in a text format with timestamp, device serial number, command and response:

```
New Session ----1/5/2026 1:19:16 PM----
1:19:26 PM: SN:53651 Sent: SP4T:1:STATE:3 Received: Success (Simulated)
1:19:29 PM: SN:53651 Sent: SP6T:2:STATE:6 Received: Success (Simulated)
1:19:33 PM: SN:53651 Sent: MTS:4:STATE:2 Received: Success (Simulated)
1:19:58 PM: SN:53651 Sent: :SP4T:1:STATE:1 Received: Success (Simulated)
1:19:58 PM: SN:53651 Sent: :SP4T:1:STATE:2 Received: Success (Simulated)
1:19:58 PM: SN:53651 Sent: :SP4T:1:STATE:3 Received: Success (Simulated)
1:19:58 PM: SN:53651 Sent: :SP4T:1:STATE:1 Received: Success (Simulated)
1:19:58 PM: SN:53651 Sent: :SP4T:1:STATE:2 Received: Success (Simulated)
1:19:58 PM: SN:53651 Sent: :SP4T:1:STATE:3 Received: Success (Simulated)
1:19:58 PM: SN:53651 Sent: :SP4T:1:STATE:1 Received: Success (Simulated)
1:19:59 PM: SN:53651 Sent: :SP4T:1:STATE:2 Received: Success (Simulated)
1:19:59 PM: SN:53651 Sent: :SP4T:1:STATE:3 Received: Success (Simulated)
1:19:59 PM: SN:53651 Sent: :SP4T:1:STATE:1 Received: Success (Simulated)
1:19:59 PM: SN:53651 Sent: :SP4T:1:STATE:2 Received: Success (Simulated)
1:19:59 PM: SN:53651 Sent: :SP4T:1:STATE:3 Received: Success (Simulated)
1:19:59 PM: SN:53651 Sent: :SP4T:1:STATE:1 Received: Success (Simulated)
1:19:59 PM: SN:53651 Sent: :SP4T:1:STATE:2 Received: Success (Simulated)
1:19:59 PM: SN:53651 Sent: :SP4T:1:STATE:3 Received: Success (Simulated)
1:19:59 PM: SN:53651 Sent: :SP4T:1:STATE:1 Received: Success (Simulated)
```

6.4. Ethernet Configuration

The Ethernet/IP Configuration section is used to edit the ethernet settings of the device.

Ethernet/IP Configuration

Mac Address: DO-73-7F-82-D8-01

DHCP Hostname: host_1

Ethernet Password: my_password

Require Password?

SSH Username: user_87

Protocols & Ports

SSH: 22 Enable

HTTP: 80 Enable

Telnet: 23 Enable

Mode

DHCP

IP Address: 192.168.20.32

Subnet Mask: 255.255.255.0

Default Gateway: 192.168.20.1

Static

IP Address: 192 . 168 . 20 . 31

Subnet Mask: 255 . 255 . 255 . 0

Default Gateway: 192 . 168 . 20 . 1

[Save Ethernet](#)

The following fields can be edited:

1. **Ethernet Password:** This is the password to associate with your device. If the 'Password Required' Boolean is selected, then all ethernet commands to the device will include this password in the command. An incorrect password will block communication with the device.
2. **Require Password Checkbox:** This is the Boolean control that sets whether the device requires the password for Ethernet communication.
3. **IP Address Mode (DHCP):** This radio buttons allows you to select DHCP (Dynamic Host Control Protocol) for your device's IP address. In this mode, the IP address is assigned by the network's DHCP server when available. If no response is received from the server, the device will revert to the default IP address of **169.254.10.10**. This static address can be used to connect to the device and control it.
4. **IP Address Mode (Static):** This radio button sets the device to use a static IP address. The IP address, gateway and subnet mask values can be set in the provided fields.
5. **SSH Username:** This field is to enter the SSH username that should be associated with the device.
6. **Protocols & Ports:** These fields are for the port values of the HTTP ports. Each port has an enable/disable toggle.

Once all the Ethernet settings have been updated, select the 'Save Ethernet' button.

Note: If the Ethernet configuration was changed while connected by Ethernet and the new configuration is not compatible with the network, it will not be possible to reconnect the sensor. Connect the sensor by USB to recover / overwrite the Ethernet configuration.

7. Control Options for macOS & Linux

Mini-Circuits is not able to provide formal software support (GUI & API) for macOS & Linux but it is possible to control Mini-Circuits' Ethernet enabled devices without any software installation, from any operating system.

The key steps to get started would be as follows.

7.1. Connect & Identify Initial IP Address

For connection into a network supporting DHCP:

1. DHCP is enabled by default so an IP address should be assigned automatically when the device is connected to the network
2. Identify the assigned IP address by referring to the network administrator or router.
3. Alternatively, a broadcast query can be sent to the network using UDP so that all Mini-Circuits devices respond with their IP (refer to the programming manual)
4. Once identified, the dynamic IP can be used to connect and control the device, including to set a new static IP configuration if required

For a direct connection between the computer and Mini-Circuits device:

1. For devices with the latest firmware, a default "link-local" IP of 169.254.10.10 will be set if no response is received from a DHCP server (which will be the case for a direct computer connection)
2. It may be necessary to configure a complimentary IP address on the computer (see [Direct Ethernet Cable Connection to PC](#))
3. This IP can be used to connect to the device and update the Ethernet configuration as needed

7.2. Updating the Ethernet Configuration

Once the initial IP address has been identified using the above steps, the device can be connected in order to set a new static IP address configuration. This can be achieved using Mini-Circuits' HTML configuration tool, details of which can be seen in [Ethernet Configuration Tool](#).

With a valid IP address, the full list of ASCII / SCPI commands summarized in this programming manual can be used to control the device programmatically, or the web browser options details above can be used.

The fallback in the event of an unknown or invalid IP configuration would be to connect the device by USB in order to overwrite the configuration.

7.3. USB Control

Control of the device using USB control is possible by using the USB interrupt method summarized in the programming manual. No Mini-Circuits API is available for this method so it involves working directly with the USB HID API. This control method is not formerly supported by Mini-Circuits.

8. Contact

Mini-Circuits

13 Neptune Avenue

Brooklyn, NY 11235

Phone: +1-718-934-4500

Email: testsolutions@minicircuits.com

Web: www.minicircuits.com

Important Notice

This document is owned by Mini-Circuits and is protected by copyright, trademark and other intellectual property laws.

The information herein is provided by Mini-Circuits as accommodation to our customers and may be used only to promote and accompany the purchase of Mini-Circuits' parts. This guide may not be reproduced, modified, distributed, published, stored in an electronic database, or transmitted and the information contained herein may not be exploited in any form or by any means, without prior written permission from Mini-Circuits.

This guide is subject to change, qualifications, variations, adjustments or modifications without notice and may contain errors, omissions, inaccuracies, mistakes or deficiencies. Mini-Circuits assumes no responsibility for, and will have no liability on account of, any of the foregoing. Accordingly, this document should be used as a guideline only.

Trademarks

All trademarks cited within this guide are the property of their respective owners. Neither Mini-Circuits nor the Mini-Circuits products are affiliated with or endorsed or sponsored by the owners of the above referenced trademarks.

Mini-Circuits and the Mini-Circuits logo are registered trademarks of Scientific Components Corporation.