

# Evaluation Board and Circuit

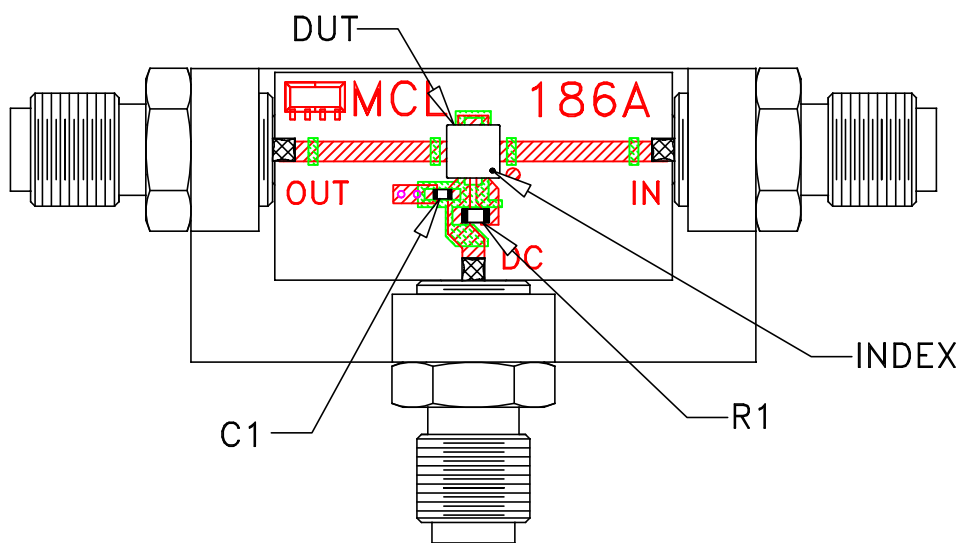

TB-186-7A+

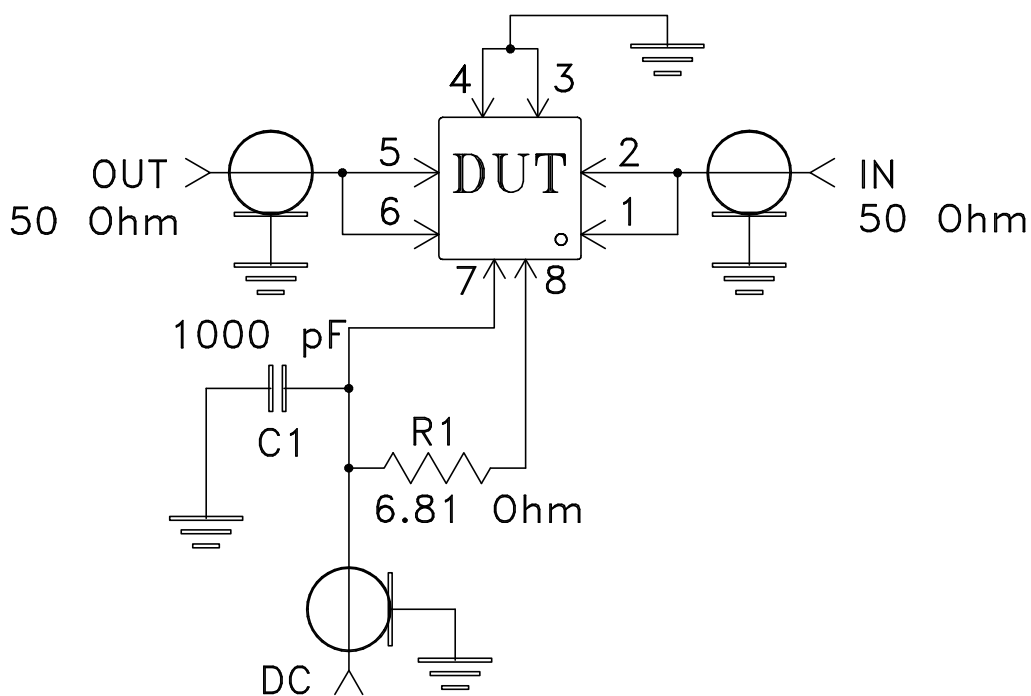

Schematic Diagram

## Notes:

1. SMA Female connectors.
2. PCB Material: Rogers R04350 or equivalent, Dielectric Constant=3.5, Thickness=.020 inch.
3. Pins 1 and 6 have no internal connecton.
4. Paddle underneath DUT must be grounded.

 **Mini-Circuits®**